



DEPARTMENT OF REGULATORY AND ECONOMIC RESOURCES (RER)
BOARD AND CODE ADMINISTRATION DIVISION

NOTICE OF ACCEPTANCE (NOA)

MIAMI-DADE COUNTY
PRODUCT CONTROL SECTION
11805 SW 26 Street, Room 208
Miami, Florida 33175-2474
T (786)315-2590 F (786) 315-2599

www.miamidade.gov/economy

Latin American Tile, Inc.
17832 South Dixie Hwy
Miami, FL 33157

SCOPE:

This NOA is being issued under the applicable rules and regulations governing the use of construction materials. The documentation submitted has been reviewed and accepted by Miami-Dade County RER -Product Control Section to be used in Miami Dade County and other areas where allowed by the Authority Having Jurisdiction (AHJ).

This NOA shall not be valid after the expiration date stated below. The Miami-Dade County Product Control Section (In Miami Dade County) and/or the AHJ (in areas other than Miami Dade County) reserve the right to have this product or material tested for quality assurance purposes. If this product or material fails to perform in the accepted manner, the manufacturer will incur the expense of such testing and the AHJ may immediately revoke, modify, or suspend the use of such product or material within their jurisdiction. RER reserves the right to revoke this acceptance, if it is determined by Miami-Dade County Product Control Section that this product or material fails to meet the requirements of the applicable building code.

This product is approved as described herein, and has been designed to comply with the Florida Building Code including the High Velocity Hurricane Zone of the Florida Building Code.

DESCRIPTION: "Arizona" & "Amazona" Spanish "S" Clay Roof Tile

LABELING: Each unit shall bear a permanent label with the manufacturer's name or logo, city, state and following statement: "Miami-Dade County Product Control Approved", unless otherwise noted herein.

RENEWAL of this NOA shall be considered after a renewal application has been filed and there has been no change in the applicable building code negatively affecting the performance of this product.

TERMINATION of this NOA will occur after the expiration date or if there has been a revision or change in the materials, use, and/or manufacture of the product or process. Misuse of this NOA as an endorsement of any product, for sales, advertising or any other purposes shall automatically terminate this NOA. Failure to comply with any section of this NOA shall be cause for termination and removal of NOA.

ADVERTISEMENT: The NOA number preceded by the words Miami-Dade County, Florida, and followed by the expiration date may be displayed in advertising literature. If any portion of the NOA is displayed, then it shall be done in its entirety.

INSPECTION: A copy of this entire NOA shall be provided to the user by the manufacturer or its distributors and shall be available for inspection at the job site at the request of the Building Official.

This renews NOA 09-0713.03 and consists of pages 1 through 6.
The submitted documentation was reviewed by Juan E. Collao, R.A.



NOA No.: 14-0820.09
Expiration Date: 09/02/19
Approval Date: 10/16/14
Page 1 of 6

ROOFING ASSEMBLY APPROVAL

Category: Roofing
Sub-Category: Roofing Tiles
Material: Clay

1. SCOPE

This approves a roofing system using **Arizona & Amazona Spanish “S” Clay Roof Tiles** manufactured by **Tejar Ceramica Babilonia** and distributed by **Latin American Tile, Inc.**, as described in Section 2 of this Notice of Acceptance, and designed to comply with the Florida Building Code for High Velocity Hurricane Zone. For locations where the pressure requirements, as determined by applicable Building Code does not exceed the design pressure values obtained by calculations in compliance with RAS 127 using the values listed in section 4 herein. The attachment calculations shall be done as a moment based system.

2. PRODUCT DESCRIPTION

| <u>Manufactured by Applicant</u> | <u>Dimensions</u> | <u>Test Specifications</u> | <u>Product Description</u> |
|------------------------------------|------------------------------------------------------|----------------------------|----------------------------------------------------------------------------------------------------------------------------------------------------------|
| Arizona Spanish “S” Clay Roof Tile | L = 18.25” W = 11.75” Thickness: 0.44” | ASTM C 1167 | High profile, one-piece, ‘S’ shaped single roll clay tile with a nominal 3” headlap for direct deck, mechanically attached or adhesive set applications. |
| Amazona Spanish “S” Clay Roof Tile | L = 18.5” W = 11.5” Thickness: 0.45” | ASTM C 1167 | High profile, one-piece, ‘S’ shaped single roll clay tile with a nominal 3” headlap for direct deck, mechanically attached or adhesive set applications. |
| Trim Pieces | Length: varies Width: varies varying thickness | | Accessory trim, clay roof pieces for use at hips, rakes, ridges and valley terminations manufactured for each tile profile. |

2.1. MANUFACTURING LOCATION

1. Villa del Rosario (Cucuta), Colombia



2.2. EVIDENCE SUBMITTED

| <u>Test Agency</u> | <u>Test Identifier</u> | <u>Test Name/Report</u> | <u>Date</u> |
|--------------------------------|------------------------|-------------------------------------|-------------|
| PRI Asphalt Technologies, Inc. | SPC-004-02-05 | TAS 100 | 04/09/04 |
| | SPC-004-02-02 | TAS 101 | 04/09/04 |
| | SPC-004-02-04 | TAS 102 | 04/09/04 |
| | SPC-004-02-03 | TAS 102 | 04/09/04 |
| | SPC-005-02-01 | ASTM C 1167 | 04/09/04 |
| | SPC-004-02-01 | ASTM C 1167 | 04/09/04 |
| | SPC-021-02-01 | ASTM C 1167 | 01/31/07 |
| | SPC-022-02-01 | ASTM C 1167 | 01/31/07 |
| Florida Tec | 09-060041 | ASTM C 1167 | 06/15/09 |
| | 09-060077 | ASTM C 1167 | 06/15/09 |
| Edgar A. Ramirez, P.E. | Letter | Aerodynamic Multiplier Calculations | 10/09/14 |

3. LIMITATIONS

- 3.1 Fire classification is not part of this acceptance.
- 3.2 For mortar or adhesive set tile applications, a static field uplift test shall be performed in accordance with TAS 106.
- 3.3 Applicant shall retain the services of a Miami-Dade County Certified Laboratory to perform quarterly test in accordance with TAS 112, appendix 'A'. Such testing shall be submitted to the Miami-Dade Product Control office for review.
- 3.4 Minimum underlayment shall be in compliance with the applicable Roofing Applications Standards listed section 4.1 herein.
- 3.5 30/90 hot mopped underlayment applications may be installed perpendicular to the roof slope unless stated otherwise by the underlayment material manufacturers published literature.
- 3.6 This acceptance is for wood deck applications. Minimum deck requirements shall be in compliance with applicable building code.
- 3.7 All products listed herein shall have a quality assurance audit in accordance with the Florida Building Code and Rule 61G20-3 of the Florida Administrative Code.

4. INSTALLATION

- 4.1 **Arizona & Amazona Spanish "S" Clay Roof Tiles** and its components shall be installed in strict compliance with Roofing Application Standard RAS 118, RAS 119 and RAS 120.
- 4.2 Data For Attachment Calculations



Table 1: Average Weight (W) and Dimensions (l x w)

| Tile Profile | Weight-W (lbf) | Length-l (ft) | Width-w (ft) |
|--------------|----------------|---------------|--------------|
| Arizona | 6.8 | 1.52 | 0.98 |
| Amazona | 7.4 | 1.54 | 0.96 |

Table 2: Aerodynamic Multipliers - λ (ft³)

| Tile Profile | λ (ft ³) Direct Deck Application |
|--------------|---------------------------------------------------------|
| Arizona | 0.30 |
| Amazona | 0.31 |

Table 3: Restoring Moments due to Gravity - M_g (ft-lbf)

| Tile Profile | 2":12" | 3":12" | 4":12" | 5":12" | 6":12" | 7":12" or Greater |
|--------------|-------------|-------------|-------------|-------------|-------------|----------------------|
| | Direct Deck | Direct Deck | Direct Deck | Direct Deck | Direct Deck | Direct Deck |
| Arizona | 4.90 | 4.83 | 4.74 | 4.61 | 4.48 | 4.34 |
| Amazona | 5.19 | 5.12 | 5.01 | 4.89 | 4.74 | 4.60 |

**Table 4: Attachment Resistance Expressed as a Moment - M_f (ft-lbf)
for Mechanically Attached Systems**

| Tile Profile | Fastener Type | Direct Deck (Min 15/32" plywood) | Direct Deck (Min. 19/32" plywood) |
|-------------------|--------------------------|-------------------------------------|--------------------------------------|
| Arizona & Amazona | 1. #8 Screw ¹ | 14.90 | 14.90 |

¹ One #8 x 2 1/2" screw placed approximately 1 5/8" from the head and 4" from the side of the watercourse.

**Table 6: Attachment Resistance Expressed as a Moment - M_f (ft-lbf)
for Single Patty Adhesive Set Systems**

| Tile Profile | Tile Application | Minimum Attachment Resistance |
|-------------------|------------------------------------------------|-------------------------------|
| Arizona & Amazona | 3M™ 2-Component Foam Roof Tile Adhesive AH-160 | 70.34 ¹ |

¹ Large paddy placement of 43 grams of 3M™ 2-Component Foam Roof Tile Adhesive AH-160.



5. LABELING

All tiles shall bear the imprint or identifiable marking of the manufacturer's name or logo as seen below or following statement: "Miami-Dade County Product Control Approved".

CERAMICA BABILONIA MADE IN COLOMBIA

**ARIZONA & AMAZONA SPANISH "S" CLAY ROOF TILES LABEL
(LOCATED ON TOP SIDE OF THE TILE)**

6. BUILDING PERMIT REQUIREMENTS:

- 6.1** Application for building permit shall be accompanied by copies of the following:
 - 6.1.1** This Notice of Acceptance.
 - 6.1.2** Any other documents required by Building Official or Applicable building code in order to properly evaluate the installation of this system.



PROFILE DRAWINGS

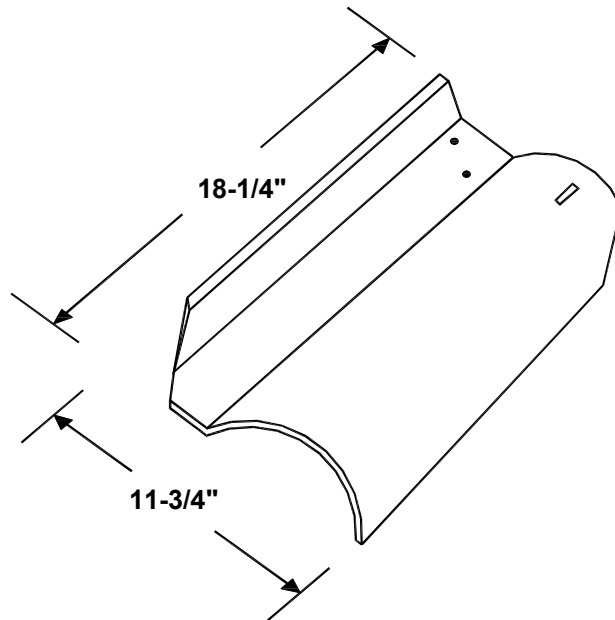

ARIZONA SPANISH "S" CLAY ROOF TILE

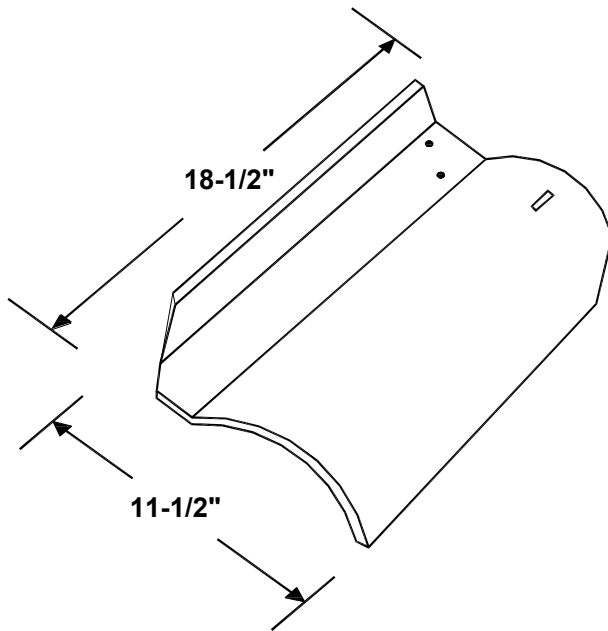

AMAZONA SPANISH "S" CLAY ROOF TILE

END OF THIS ACCEPTANCE

