



DEPARTMENT OF REGULATORY AND ECONOMIC RESOURCES (RER)  
BOARD AND CODE ADMINISTRATION DIVISION

**NOTICE OF ACCEPTANCE (NOA)**

MIAMI-DADE COUNTY  
PRODUCT CONTROL SECTION  
11805 SW 26 Street, Room 208  
Miami, Florida 33175-2474  
T (786)315-2590 F (786) 315-2599

[www.miamidade.gov/economy](http://www.miamidade.gov/economy)

**Tejas Borja, S.A.U.**  
**Carretera Liria a Pedralba Km 3**  
**Lliria, 46160 Valencia ES**

**SCOPE:**

This NOA is being issued under the applicable rules and regulations governing the use of construction materials. The documentation submitted has been reviewed and accepted by Miami-Dade County RER -Product Control Section to be used in Miami Dade County and other areas where allowed by the Authority Having Jurisdiction (AHJ).

This NOA shall not be valid after the expiration date stated below. The Miami-Dade County Product Control Section (In Miami Dade County) and/or the AHJ (in areas other than Miami Dade County) reserve the right to have this product or material tested for quality assurance purposes. If this product or material fails to perform in the accepted manner, the manufacturer will incur the expense of such testing and the AHJ may immediately revoke, modify, or suspend the use of such product or material within their jurisdiction. RER reserves the right to revoke this acceptance, if it is determined by Miami-Dade County Product Control Section that this product or material fails to meet the requirements of the applicable building code.

This product is approved as described herein, and has been designed to comply with the Florida Building Code including the High Velocity Hurricane Zone of the Florida Building Code.

**DESCRIPTION: Flat Clay Tiles**

**LABELING:** Each unit shall bear a permanent label with the manufacturer's name or logo, city, state and following statement: "Miami-Dade County Product Control Approved", unless otherwise noted herein.

**RENEWAL** of this NOA shall be considered after a renewal application has been filed and there has been no change in the applicable building code negatively affecting the performance of this product.

**TERMINATION** of this NOA will occur after the expiration date or if there has been a revision or change in the materials, use, and/or manufacture of the product or process. Misuse of this NOA as an endorsement of any product, for sales, advertising or any other purposes shall automatically terminate this NOA. Failure to comply with any section of this NOA shall be cause for termination and removal of NOA.

**ADVERTISEMENT:** The NOA number preceded by the words Miami-Dade County, Florida, and followed by the expiration date may be displayed in advertising literature. If any portion of the NOA is displayed, then it shall be done in its entirety.

**INSPECTION:** A copy of this entire NOA shall be provided to the user by the manufacturer or its distributors and shall be available for inspection at the job site at the request of the Building Official.

This NOA revises NOA 12-0416.15 and it consists of pages 1 through 8.  
The submitted documentation was reviewed by Alex Tigera.



NOA No.: 14-1103.01  
Expiration Date: 04/19/17  
Approval Date: 02/04/16  
Page 1 of 8

## ROOFING ASSEMBLY APPROVAL

**Category:** Roofing  
**Sub-Category:** Roofing Tiles  
**Material:** Clay

### 1. SCOPE

This approves a roofing system using **TB-Flat 10 & TB-Flat 12 Clay Roof Tiles**, as manufactured by **Tejas Borja S.A.U. in Lliria, Spain** and distributed by **Masterpiece Building Products, LLC**, and described in Section 2 of this Notice of Acceptance. For locations where the pressure requirements, as determined by applicable Building Code does not exceed the design pressure values obtained by calculations in compliance with RAS 127 using the values listed in section 4 herein. The attachment calculations shall be done as a moment based system.

### 2. PRODUCT DESCRIPTION

<u>Manufactured by Applicant</u>	<u>Dimensions</u>	<u>Test Specifications</u>	<u>Product Description</u>
<b>TB-Flat 10</b>	L = 17.76" W = 11.3" H = 0.77" Thickness: 0.34"	ASTM C 1167 Type III Grade 1	Flat, interlocking, clay tile equipped with two nail holes. For direct deck or battened nail-on, mortar or adhesive set applications.
<b>TB-Flat 12</b>	L = 16" W = 11" H = 0.4" Thickness: 1"	ASTM C 1167 Type III Grade 1	Flat, interlocking, clay tile equipped with two nail holes with smooth, shake, and slate textures. For direct deck nail-on, mortar or adhesive set applications.
<b>Trim Pieces</b>	L= varies W = varies Varying thickness	ASTM C 1167	Accessory trim, clay roof pieces for use at hips, rakes, ridges and valley terminations. Manufactured for each tile profile.

#### 2.1 PRODUCTS MANUFACTURED BY OTHERS

<u>Product Name</u>	<u>Product Description</u>	<u>Manufacturer (With Current NOA)</u>
3M™ 2- Component Foam Roof Tile Adhesive AH-160	Two component polyurethane foam adhesive.	3M Company
TILE BOND™ Roof Tile Adhesive	Single component polyurethane foam roof tile adhesive.	The Dow Chemical Company
“Tile Tite” Roof Tile Mortar	Premixed, pre-bagged roof tile mortar.	Bermuda Roof Co. Inc.
Bonsal Roof Tile Mortar	Premixed, pre-bagged roof tile mortar.	Bonsal American
“Quikrete” Roof Tile Mortar, FL-15	Premixed, pre-bagged gray roof tile mortar.	The Quikrete Companies, Inc.

#### 2.2 MANUFACTURING LOCATION

- Lliria, Spain



## 2.3 SUBMITTED EVIDENCE:

<u>Test Agency</u>	<u>Test Identifier</u>	<u>Test Name/Report</u>	<u>Date</u>
Redland Technologies	7161-03 Appendix III	PA 102 & PA 102(A)	Dec. 1991
	7161-03 Appendix II	PA 108 (Nail-On)	Dec. 1991
	Letter	PA 108 (Nail-On)	Aug. 1994
	P0631-01	PA 108 (Mortar Set)	July 1994
	P0402	Withdrawal Resistance Testing of screw vs. smooth shank nails	Sept. 1993
The Center for Applied Engineering, Inc.	94-060A	PA 101 (Mortar Set)	March, 1994
	94-084	PA 101 (Adhesive Set)	May 1994
	25-7094-2	PA 102 (4" Headlap, Nails, Direct Deck, New Construction)	Oct. 1994
	25-7094-8	PA 102 (4" Headlap, Nails, Battens)	Oct. 1994
	25-7094-5	PA 102 (4" Headlap, Nails, Direct Deck, Recover/Reroof)	Oct. 1994
	25-7183-6	PA 102 (2 Quik-Drive Screws, Direct Deck)	Feb. 1995
	25-7183-5	PA 102 (2 Quik-Drive Screws, Battens)	Feb. 1995
	25-7214-1	PA 102 (1 Quik-Drive Screw, Direct Deck)	March, 1995
	25-7214-5	PA 102 (1 Quik-Drive Screw, Battens)	March, 1995
	Project No. 307025 Test #MDC-77	PA 100	Oct. 1994
Celotex Corporation Testing Service	520109-1	PA 101	Dec. 1998
	520111-4	PA 101	March 1999
	520191-1	PA 101	March 1999
Walker Engineering, Inc.	Calculations	Aerodynamic Multiplier	03/03/06
	Calculations	Restoring Moments due to Gravity	03/07/06
	Calculations	25-7094	February 1996
	Calculations	25-7496	April 1996
	Calculations	25-7584	December 1996
	Calculations	25-7804b-8	December 1996
	Calculations	25-7804-4 & 5	December 1996
	Calculations	25-7848-6	December 1996
	Calculations	25-7183	March 1995
	Calculations	Aerodynamic Multipliers	April 1999
	Calculations	Two Patty Adhesive Set System	April 1999
PRI Construction Materials Technologies	TBU-001-02-01	ASTM C 1167	01/09/07
	RT0919.01-14	ASTM C 1167	09/26/14
American Test Lab of South Florida	RT0926.01-14	Restoring Moment Aerodynamic Multiplier	09/26/14

### 3. LIMITATIONS:

- 3.1 Fire classification is not part of this acceptance.
- 3.2 For mortar or adhesive set tile applications, a static field uplift test shall be performed in accordance with TAS 106.
- 3.3 Applicant shall retain the services of a Miami-Dade County Certified Laboratory to perform quarterly test in accordance with TAS 112, appendix 'A'. Such testing shall be submitted to the Miami-Dade Product Control office for review.
- 3.4 Minimum underlayment shall be in compliance with the applicable Roofing Applications Standards listed section 4.1 herein.
- 3.5 30/90 hot mopped underlayment applications may be installed perpendicular to the roof slope unless stated otherwise by the underlayment material manufacturers published literature.
- 3.6 This acceptance is for wood deck applications. Minimum deck requirements shall be in compliance with applicable building code.
- 3.7 All products listed herein shall have a quality assurance audit in accordance with the Florida Building Code and Rule 61G20-3 of the Florida Administrative Code.

### 4. INSTALLATION:

- 4.1 **TB-Flat 10 & TB-Flat 12** and its components shall be installed in strict compliance with Roofing Application Standard RAS 118, RAS 119, and RAS 120.
- 4.2 Data For Attachment Calculations

Table 1: Average Weight (W) and Dimensions (l x w )			
Tile Profile	Weight-W (lbf)	Length-l (ft)	Width-w (ft)
TB-Flat 10	8.157	1.48	0.941
TB-Flat 12	7.0	1.33	0.916

Table 2: Aerodynamic Multipliers - $\lambda$ (ft <sup>3</sup> )		
Tile Profile	$\lambda$ (ft <sup>3</sup> ) Batten Application	$\lambda$ (ft <sup>3</sup> ) Direct Deck Application
TB-Flat 10	0.263	0.285
TB-Flat 12	N/A	0.218

Table 3: Restoring Moments due to Gravity - M <sub>g</sub> (ft-lbf)												
Tile Profile	2":12"		3":12"		4":12"		5":12"		6":12"		7":12" or greater	
	Battens	Direct Deck	Battens	Direct Deck	Battens	Direct Deck	Battens	Direct Deck	Battens	Direct Deck	Battens	Direct Deck
TB-Flat 10	6.00	6.01	5.93	5.94	5.82	5.83	5.69	5.71	5.54	5.55	5.37	5.39
TB-Flat 12	N/A	N/A	N/A	4.31	N/A	4.23	N/A	4.13	N/A	4.01	N/A	3.88



**Table 4: Attachment Resistance Expressed as a Moment - M<sub>f</sub> (ft-lbf)  
for Mechanically Attached Systems**

<b>Tile Profile</b>	<b>Fastener Type</b>	<b>Direct Deck (min 15/32" plywood)</b>	<b>Direct Deck (min. 19/32" plywood)</b>	<b>Battens</b>
TB-Flat 10, TB-Flat 12	2-10d Ring Shank Nails	30.9	38.1	17.2
	1-10d Smooth or Screw Shank Nail	7.3	9.8	4.9
	2-10d Smooth or Screw Shank Nails	14.0	18.8	7.4
	1 #8 Screw	30.8	30.8	18.2
	2 #8 Screw	51.7	51.7	24.4
	1-10d Smooth or Screw Shank Nail (Field Clip)	24.3	24.3	24.2
	1-10d Smooth or Screw Shank Nail (Eave Clip)	19.0	19.0	22.1
	2-10d Smooth or Screw Shank Nails (Field Clip)	35.5	35.5	34.8
	2-10d Smooth or Screw Shank Nails (Eave Clip)	31.9	31.9	32.2
		2-10d Ring Shank Nails <sup>1</sup>	50.3	65.5

<sup>1</sup> Installation with a 4" tile headlap and fasteners are located a min. of 2½" from head of tile.

**Table 5: Attachment Resistance Expressed as a Moment M<sub>f</sub> (ft-lbf)  
for Two Patty Adhesive Set Systems**

<b>Tile Profile</b>	<b>Tile Application</b>	<b>Minimum Attachment Resistance</b>
TB-Flat 10 TB-Flat 12	Adhesive <sup>2</sup>	31.3 <sup>3</sup>

<sup>2</sup> See manufacturer's component approval for installation requirements.

<sup>3</sup> TILE BOND™ Roof Tile Adhesive; Average weight per patty 13.9 grams.

3M™ 2-Component Foam Roof Tile Adhesive AH-160; Average weight per patty 8 grams.



Table 6: Attachment Resistance Expressed as a Moment - $M_f$ (ft-lbf) for Single Patty Adhesive Set Systems		
Tile Profile	Tile Application	Minimum Attachment Resistance
TB-Flat 10	3M™ 2-Component Foam Roof Tile Adhesive AH-160	118.9 <sup>4</sup>
TB-Flat 12	3M™ 2-Component Foam Roof Tile Adhesive AH-160	40.4 <sup>5</sup>
4 Large paddy placement of 45 grams of 3M™ 2-Component Foam Roof Tile Adhesive AH-160.		
5 Medium paddy placement of 24 grams of 3M™ 2-Component Foam Roof Tile Adhesive AH-160.		

Table 7: Attachment Resistance Expressed as a Moment - $M_f$ (ft-lbf) for Mortar Set Systems		
Tile Profile	Tile Application	Attachment Resistance
TB-Flat 10 TB-Flat 12	Mortar Set <sup>6</sup>	39.0
6 See specific mortar manufacturers Notice of Acceptance		

## 5. LABELING:

All tiles shall bear the imprint or identifiable marking of the manufacturer's name or logo (See Detail Below), or following statement: "Miami-Dade County Product Control Approved".

**MADE IN EU**

**FLAT 10 E C€**

**TB-FLAT 10 TILE LABEL  
(LOCATED ON TOP OF TILE)**



**TEJAS BORJA**

**TB-FLAT 12 TILE LABEL  
(LOCATED ON UNDERSIDE OF TILE)**

## 6. BUILDING PERMIT REQUIREMENTS:

6.1 Application for building permit shall be accompanied by copies of the following:

6.1.1 This Notice of Acceptance.

6.1.2 Any other documents required by Building Official or Applicable building code in order to properly evaluate the installation of this system.



NOA No.: 14-1103.01  
 Expiration Date: 04/19/17  
 Approval Date: 02/04/16  
 Page 6 of 8

# PROFILE DRAWINGS

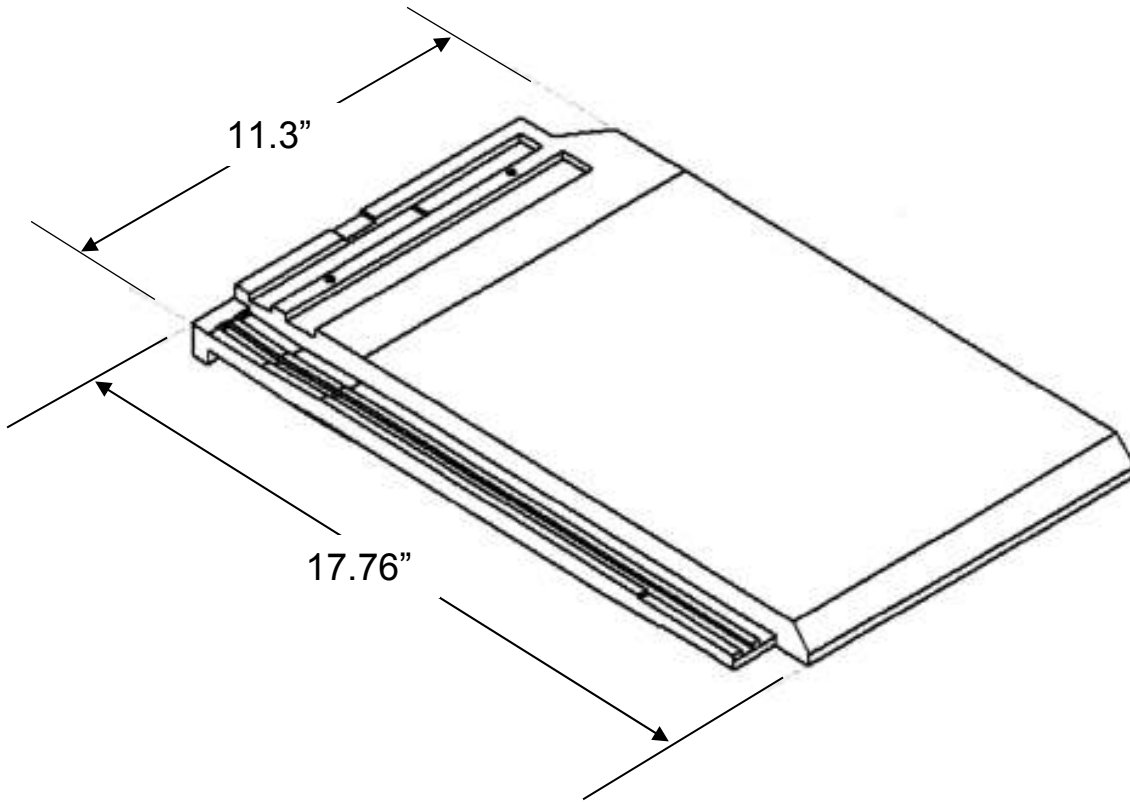

**TB-FLAT 10 CLAY ROOF TILE**



**PROFILE DRAWINGS (CONTINUED)**

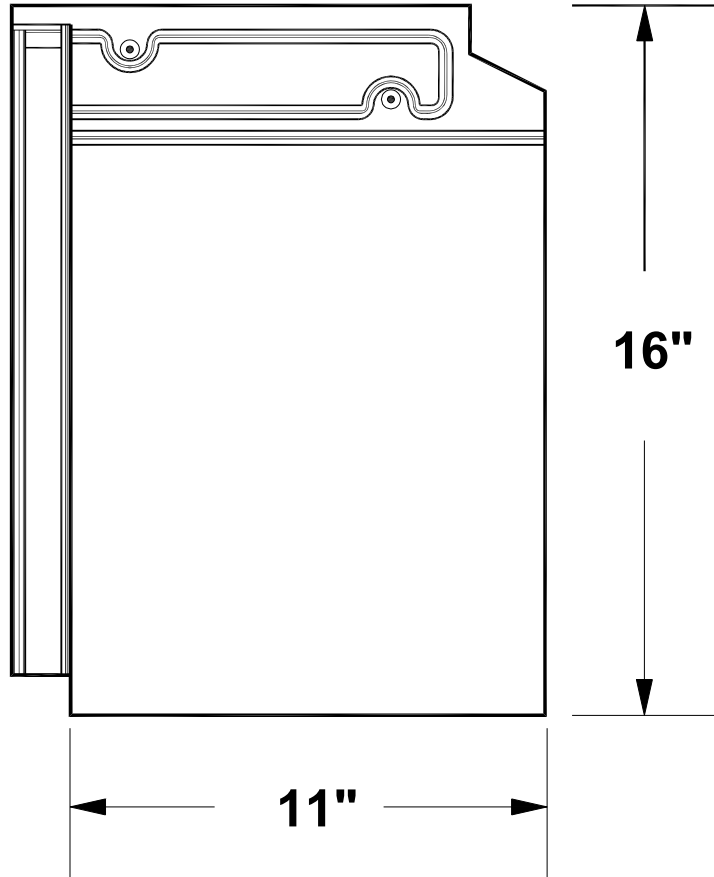

**FLAT CLAY TILE**

**END OF THIS ACCEPTANCE**