



DEPARTMENT OF REGULATORY AND ECONOMIC RESOURCES (RER)  
BOARD AND CODE ADMINISTRATION DIVISION

MIAMI-DADE COUNTY  
PRODUCT CONTROL SECTION  
11805 SW 26 Street, Room 208  
T (786) 315-2590 F (786) 315-2599

[www.miamidade.gov/economy](http://www.miamidade.gov/economy)

**NOTICE OF ACCEPTANCE (NOA)**

Mr. Glass Doors & Windows, Inc.  
7440 NW 66 Street  
Miami, FL 33166

**SCOPE:**

This NOA is being issued under the applicable rules and regulations governing the use of construction materials. The documentation submitted has been reviewed and accepted by Miami-Dade County RER - Product Control Section to be used in Miami Dade County and other areas where allowed by the Authority Having Jurisdiction (AHJ).

This NOA shall not be valid after the expiration date stated below. The Miami-Dade County Product Control Section (In Miami-Dade County) and/or the AHJ (in areas other than Miami-Dade County) reserve the right to have this product or material tested for quality assurance purposes. If this product or material fails to perform in the accepted manner, the manufacturer will incur the expense of such testing and the AHJ may immediately revoke, modify, or suspend the use of such product or material within their jurisdiction. RER reserves the right to revoke this acceptance, if it is determined by Miami-Dade County Product Control Section that this product or material fails to meet the requirements of the applicable building code.

This product is approved as described herein, and has been designed to comply with the Florida Building Code, including the High Velocity Hurricane Zone.-

**DESCRIPTION: Series "MG-4500" Aluminum Storefront System – N.I.**

**APPROVAL DOCUMENT:** Drawing No. W10-75, titled "MG-4500 Aluminum Flush Glazed System (N.I.)", sheets 1 through 9 of 9, dated 10/15/10, with revision B dated 03/04/15, prepared by Al-Farooq Corporation, signed and sealed by Javad Ahmad, P.E., bearing the Miami-Dade County Product Control Revision stamp with the Notice of Acceptance number and expiration date by the Miami-Dade County Product Control Section.

**MISSILE IMPACT RATING: None.**

**LABELING:** Each unit shall bear a permanent label with the manufacturer's name or logo, city, state, model/series, and following statement: "Miami-Dade County Product Control Approved", unless otherwise noted herein.

**RENEWAL** of this NOA shall be considered after a renewal application has been filed and there has been no change in the applicable building code negatively affecting the performance of this product.

**TERMINATION** of this NOA will occur after the expiration date or if there has been a revision or change in the materials, use, and/or manufacture of the product or process. Misuse of this NOA as an endorsement of any product, for sales, advertising or any other purposes shall automatically terminate this NOA. Failure to comply with any section of this NOA shall be cause for termination and removal of NOA.

**ADVERTISEMENT:** The NOA number preceded by the words Miami-Dade County, Florida, and followed by the expiration date may be displayed in advertising literature. If any portion of the NOA is displayed, then it shall be done in its entirety.

**INSPECTION:** A copy of this entire NOA shall be provided to the user by the manufacturer or its distributors and shall be available for inspection at the job site at the request of the Building Official.

This NOA revises NOA# 11-0720.08 and consists of this page 1 and evidence pages E-1 and E-2, as well as approval document mentioned above.

The submitted documentation was reviewed by Manuel Perez, P.E.



*Handwritten signature and date: MP 7/6/30/15*

NOA No. 15-0401.01  
Expiration Date: October 06, 2016  
Approval Date: July 09 2015  
Page 1

NOTICE OF ACCEPTANCE: EVIDENCE SUBMITTED

**A. DRAWINGS**

1. Manufacturer's die drawings and sections.
2. Drawing No. **W10-75**, titled "MG-4500 Aluminum Flush Glazed System (N.I.)", sheets 1 through 9 of 9, dated 10/15/10, with revision B dated 03/04/15, prepared by Al-Farooq Corporation, signed and sealed by Javad Ahmad, P.E.

**B. TESTS**

1. Test reports on: 1) Air Infiltration Test, per FBC, TAS 202-94  
2) Uniform Static Air Pressure Test, Loading per FBC TAS 202-94  
along with marked-up drawings and installation diagram of an aluminum storefront and storefront door system, prepared by Hurricane Engineering & Testing, Inc., Test Report No. **HETI-09-2545**, dated 09/25/09, signed and sealed by Candido F. Font, P.E.  
*(Submitted under previous NOA No. 11-0720.08)*
2. Test reports on: 1) Air Infiltration Test, per FBC, TAS 202-94  
2) Uniform Static Air Pressure Test, Loading per FBC TAS 202-94  
3) Water Resistance Test, per FBC, TAS 202-94  
along with marked-up drawings and installation diagram of an aluminum storefront system, prepared by Hurricane Engineering & Testing, Inc., Test Report No. **HETI-09-2546**, dated 09/16/09, signed and sealed by Candido F. Font, P.E.  
*(Submitted under previous NOA No. 11-0720.08)*
3. Test reports on: 1) Air Infiltration Test, per FBC, TAS 202-94  
2) Uniform Static Air Pressure Test, Loading per FBC TAS 202-94  
3) Water Resistance Test, per FBC, TAS 202-94  
4) Forced Entry Test, per FBC TAS 202-94 and AAMA 1304-02  
along with marked-up drawings and installation diagram of an aluminum storefront system with a pair of doors, prepared by Hurricane Engineering & Testing, Inc., Test Report No. **HETI-09-2550**, dated 09/16/09, signed and sealed by Candido F. Font, P.E.  
*(Submitted under previous NOA No. 11-0720.08)*
4. Test reports on: 1) Air Infiltration Test, per FBC, TAS 202-94  
2) Uniform Static Air Pressure Test, Loading per FBC TAS 202-94  
3) Forced Entry Test, per FBC TAS 202-94 and AAMA 1304-02  
along with marked-up drawings and installation diagram of an aluminum storefront door system, prepared by Hurricane Engineering & Testing, Inc., Test Report No. **HETI-09-2549**, dated 09/16/09, signed and sealed by Candido F. Font, P.E.  
*(Submitted under previous NOA No. 11-0720.08)*

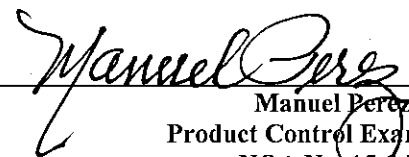

Manuel Perez, P.E.  
Product Control Examiner  
NOA No. 15-0401.01

Expiration Date: October 06, 2016  
Approval Date: July 09 2015

NOTICE OF ACCEPTANCE: EVIDENCE SUBMITTED

**B. TESTS (CONTINUED)**

5. Test reports on: 1) Air Infiltration Test, per FBC, TAS 202-94  
2) Uniform Static Air Pressure Test, Loading per FBC TAS 202-94  
3) Forced Entry Test, per FBC TAS 202-94 and AAMA 1304-02  
along with marked-up drawings and installation diagram of an aluminum storefront door system, prepared by Hurricane Engineering & Testing, Inc., Test Report No. **HETI-09-2548**, dated 09/16/09, signed and sealed by Candido F. Font, P.E.  
*(Submitted under previous NOA No. 11-0720.08)*
6. Test reports on: 1) Uniform Static Air Pressure Test, Loading per FBC TAS 202-94  
2) Forced Entry Test, per FBC TAS 202-94 and AAMA 1304-02  
along with marked-up drawings and installation diagram of an aluminum storefront door system, prepared by Hurricane Engineering & Testing, Inc., Test Report No. **HETI-09-2547**, dated 09/16/09, signed and sealed by Candido F. Font, P.E.  
*(Submitted under previous NOA No. 11-0720.08)*

**C. CALCULATIONS**

1. Anchor verification calculations and structural analysis, complying with **FBC-5<sup>th</sup> Edition (2014)**, dated 02/27/15, prepared by Al-Farooq Corporation, signed and sealed by Javad Ahmad, P.E.
2. Glazing complies with **ASTM E1300-09**

**D. QUALITY ASSURANCE**

1. Miami-Dade Department of Regulatory and Economic Resources (RER).

**E. MATERIAL CERTIFICATIONS**

1. None.

**F. STATEMENTS**

1. Statement letter of conformance, complying with **FBC-5<sup>th</sup> Edition (2014)**, and of no financial interest, dated February 27, 2015, issued by Al-Farooq Corporation, signed and sealed by Javad Ahmad, P.E.
2. Laboratory compliance letter for Test Reports No. **HETI-09-2545, HETI-09-2546, HETI-09-2547, HETI-09-2548, HETI-09-2549** and **HETI-09-2550**, issued by Hurricane Engineering & Testing, Inc., dated 09/16/09, signed and sealed by Candido F. Font, P.E. *(Submitted under previous NOA No.11-0720.08)*

**G. OTHERS**

1. Notice of Acceptance No. **11-0720.08**, issued to Mr. Glass Doors & Windows, Inc. for their Series "MG-4500" Aluminum Storefront System - N.I., approved on 10/06/11 and expiring on 10/06/16.

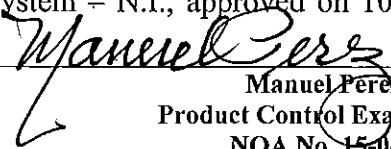
  
Manuel Perez, P.E.  
Product Control Examiner  
NOA No. 15-0401.01  
Expiration Date: October 06, 2016  
Approval Date: July 09 2015

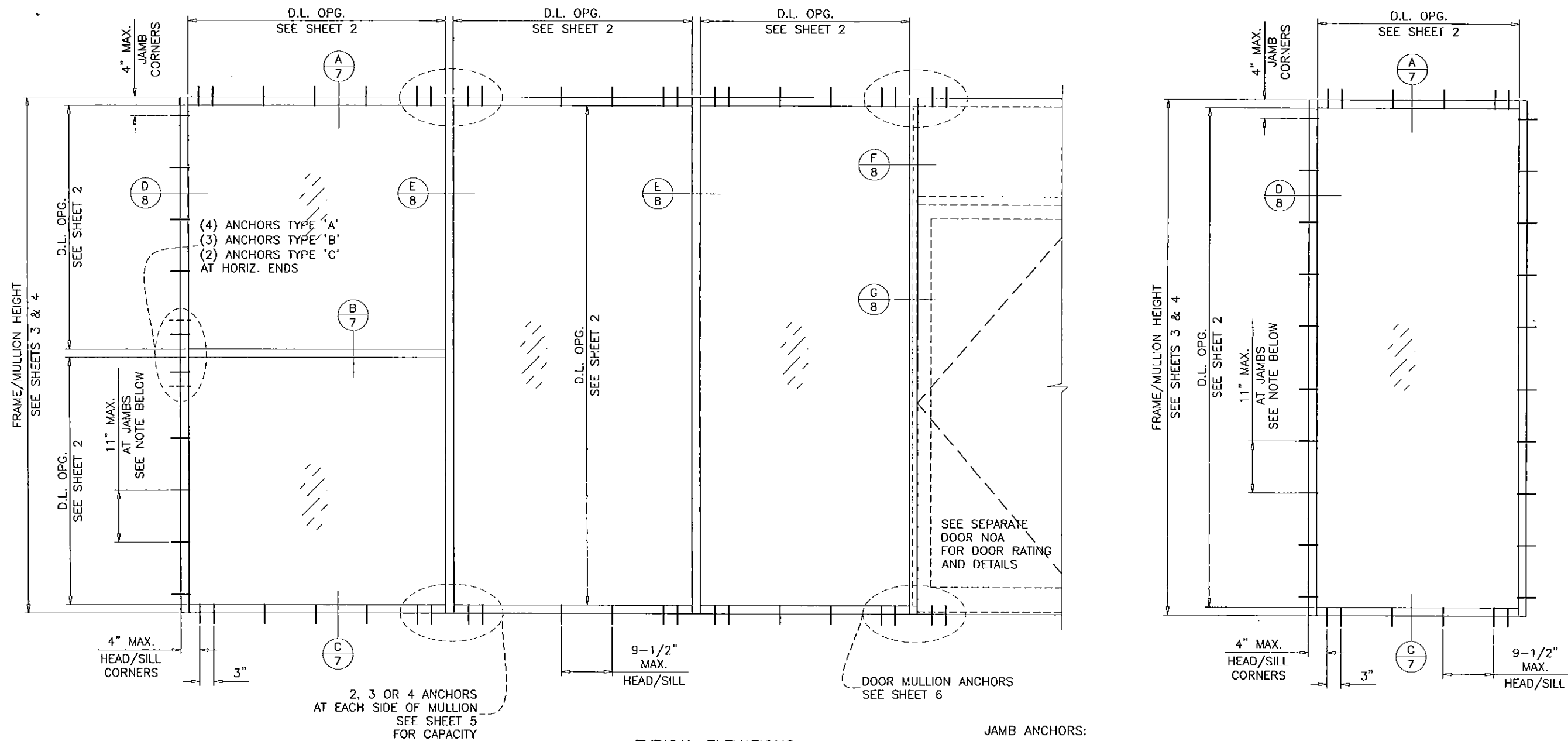

**TYPICAL ELEVATIONS**

JAMB ANCHORS:  
LIMIT MAX. LOAD TO 85.0 PSF  
FOR ANCHOR TYPE 'A' ONLY

**MG-4500  
ALUMINUM FLUSH GLAZED STOREFRONT SYSTEM**

THIS SYSTEM MAY BE USED IN CONJUNCTION WITH MIAMI-DADE COUNTY APPROVED FRENCH DOORS. LOWER DESIGN PRESSURE FROM STOREFRONT OR DOOR APPROVAL WILL APPLY TO ENTIRE SYSTEM.

CODE REQUIREMENTS FOR SAFEGUARDS MUST BE OBSERVED.

THIS PRODUCT HAS BEEN DESIGNED AND TESTED TO COMPLY WITH THE REQUIREMENTS OF THE FLORIDA BUILDING CODE INCLUDING HIGH VELOCITY HURRICANE ZONE (HVHZ).

WOOD BUCKS BY OTHERS, MUST BE ANCHORED PROPERLY TO TRANSFER LOADS TO THE STRUCTURE.

ANCHORS SHALL BE AS LISTED, SPACED AS SHOWN ON DETAILS, ANCHORS EMBEDMENT TO BASE MATERIAL SHALL BE BEYOND WALL DRESSING OR STUCCO.

ANCHORING OR LOADING CONDITIONS NOT SHOWN IN THESE DETAILS ARE NOT PART OF THIS APPROVAL.

A LOAD DURATION INCREASE IS USED IN DESIGN OF ANCHORS INTO WOOD ONLY.

ALL SHIMS TO BE HIGH IMPACT, NON-METALLIC AND NON-COMPRESSIBLE.

MATERIALS INCLUDING BUT NOT LIMITED TO STEEL/METAL SCREWS, THAT COME INTO CONTACT WITH OTHER DISSIMILAR MATERIALS SHALL MEET THE REQUIREMENTS OF THE FLORIDA BUILDING CODE.

**INSTRUCTIONS:**

USE CHARTS AS FOLLOWS.

- STEP 1** DETERMINE DESIGN WIND LOAD REQUIREMENT BASED ON WIND VELOCITY, BLDG. HEIGHT, WIND ZONE USING APPLICABLE ASCE 7 STANDARD.
- STEP 2** SEE CHARTS ON SHEET 2 FOR DESIGN LOAD CAPACITY OF DESIRED GLASS SIZE.
- STEP 3** CHECK MULLION CAPACITY FOR A GIVEN SPACING AND HEIGHT USING CHARTS ON SHEETS 3 & 4 FOR STOREFRONT MULLION AND SHEET 6 FOR DOOR MULLION. THE CAPACITY SHOULD EXCEED THE DESIGN LOAD.
- STEP 4** USING CHART ON SHEET 5 SELECT ANCHOR OPTION WITH DESIGN RATING MORE THAN DESIGN LOAD SPECIFIED IN STEP 1 ABOVE.
- STEP 5** THE LOWEST VALUE RESULTING FROM STEPS 2, 3 AND 4 SHALL APPLY TO ENTIRE SYSTEM.

THIS SYSTEM IS NOT RATED FOR IMPACT. INSTALLATION OF THIS PRODUCT IN THE HVHZ AREA REQUIRES THE USE OF APPROVED SHUTTERS OR EXTERNAL PROTECTION DEVICES COMPLYING WITH HVHZ REQUIREMENTS. INSTALLATION OF THIS SYSTEM OUTSIDE THE HVHZ AREA SHALL MEET THE APPLICABLE REQUIREMENTS FOR WIND BORNE DEBRIS PROTECTION.

Engr: JAVAD AHMAD  
CML  
FLA. PE # 70592  
C.A.N. 3538  
*[Signature]*  
MAR 11 2015

PRODUCT REVISED  
as complying with the Florida  
Building Code  
Acceptance No. 15-0401.01  
Expiration Date Oct. 6, 2016  
By *[Signature]*  
Miami Dade Product Control

**af c**  
**AL-FAROOQ CORPORATION**  
ENGINEERS & PRODUCT DEVELOPMENT  
1235 S.W. 87 AVE  
MIAMI, FLORIDA 33174  
TEL. (305) 264-8100 FAX. (305) 262-6978  
COMP-ANL\W10-75MRG

MG-4500 ALUMINUM FLUSH GLAZED SYSTEM (N.I.)  
**MR. GLASS DOORS & WINDOWS INC.**  
7440 N.W. 66 STREET  
MIAMI, FL. 33166  
TEL. (305) 470-8284 FAX. (305) 470-8285

NO	DATE	DESCRIPTION
A	09.14.11	REV. PER BNC COMMENTS
B	03.04.15	UPDATED TO 2014 FBC

date: 10-15-10  
scale: 1/2"=1'-0"  
dr. by: HAMID  
chk. by:

drawing no.  
**W10-75**

sheet 1 of 9

GLASS LOAD CAPACITY - PSF		
NOMINAL DIMS.		1/4" TEMP. GLASS
D.L.O. WIDTH	D.L.O. HEIGHT	EXT.(+)/INT.(-)
22-1/4"	68-1/2"	100.0
28-1/4"		100.0
34-1/4"		100.0
40-1/4"		100.0
46-1/4"		100.0
52-1/4"		100.0
58-1/4"		100.0
64-1/4"		100.0
22-1/4"	74-1/2"	100.0
28-1/4"		100.0
34-1/4"		100.0
40-1/4"		100.0
46-1/4"		100.0
52-1/4"		100.0
58-1/4"		100.0
64-1/4"		100.0
22-1/4"	80-1/2"	100.0
28-1/4"		100.0
34-1/4"		100.0
40-1/4"		100.0
46-1/4"		100.0
52-1/4"		100.0
58-1/4"		100.0
64-1/4"		100.0
22-1/4"	86-1/2"	100.0
28-1/4"		100.0
34-1/4"		100.0
40-1/4"		100.0
46-1/4"		100.0
52-1/4"		100.0
58-1/4"		100.0
64-1/4"		100.0
22-1/4"	92-1/2"	100.0
28-1/4"		100.0
34-1/4"		100.0
40-1/4"		100.0
46-1/4"		100.0
52-1/4"		100.0
58-1/4"		100.0
64-1/4"		100.0
22-1/4"	94-1/2"	100.0
28-1/4"		100.0
34-1/4"		100.0
40-1/4"		100.0
46-1/4"		100.0
52-1/4"		100.0
58-1/4"		100.0
64-1/4"		100.0

GLASS LOAD CAPACITY - PSF		
NOMINAL DIMS.		1/4" TEMP. GLASS
D.L.O. WIDTH	D.L.O. HEIGHT	EXT.(+)/INT.(-)
22-1/4"	98-1/2"	100.0
28-1/4"		100.0
34-1/4"		100.0
40-1/4"		100.0
46-1/4"		100.0
22-1/4"	104-1/2"	100.0
28-1/4"		100.0
34-1/4"		100.0
40-1/4"		100.0
22-1/4"	110-1/2"	100.0
28-1/4"		100.0
34-1/4"		100.0
40-1/4"		100.0
22-1/4"	116-1/2"	100.0
28-1/4"		100.0
34-1/4"		100.0
40-1/4"		100.0

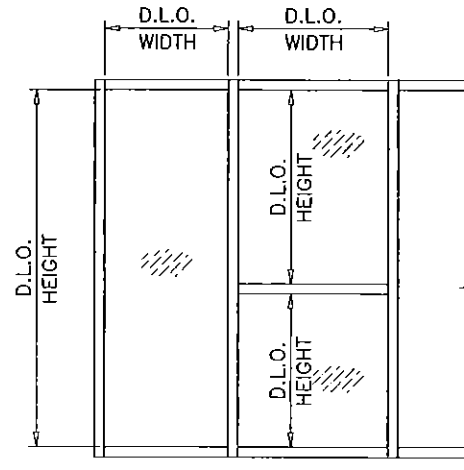

NOTE:  
INTERPOLATION BETWEEN WIDTHS OR HEIGHTS ALLOWED.

LOADS SHOWN IN CHARTS ARE FOR INSTALLATIONS WHERE WATER INFILTRATION RESISTANCE IS NOT REQUIRED. LIMIT EXTERIOR LOADS TO +60.0 PSF FOR INSTALLATIONS WHERE WATER INFILTRATION RESISTANCE IS REQUIRED.

NOTE:  
GLASS CAPACITIES ON THIS SHEET ARE BASED ON ASTM E1300-09 (3 SEC. GUSTS).

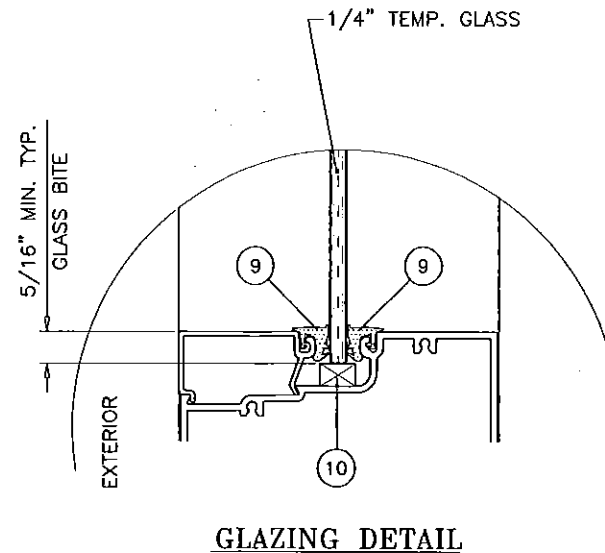

Engr: JAVAD AHMAD  
CIVIL  
FLA. PE # 70592  
C.A.N. 3538

MAR 11 2015

PRODUCT REVISED  
as complying with the Florida  
Building Code  
Acceptance No 15-0401.01  
Expiration Date 02.6.2016

chk. by: *Manuel P...*  
Miami Dade Product Control

GLASS

**afc**  
**AL-FAROOQ CORPORATION**  
ENGINEERS & PRODUCT DEVELOPMENT  
1235 S.W. 87 AVE  
MIAMI, FLORIDA 33174  
TEL. (305) 264-8100 FAX. (305) 262-6978  
COMP-ANL\W10-75MRG

MG-4500 ALUMINUM FLUSH GLAZED SYSTEM (N.I.)  
MR. GLASS DOORS & WINDOWS INC.  
7440 N.W. 66 STREET  
MIAMI, FL. 33166  
TEL. (305) 470-8284 FAX. (305) 470-8285

no.	date	by	description
A	08.14.11		NO CHANGE THIS SHEET
B	03.04.15		UPDATED TO 2014 FBC

date: 10-15-10  
scale: 3/8" = 1"  
dr. by: HAMID  
chk. by:

drawing no.  
**W10-75**  
sheet 2 of 9

MULLION LOAD CAPACITY - PSF WITHOUT INTERMEDIATE HORIZONTALS					
NOMINAL DIMS.		MULLION 'M1'	MULLION 'M2'	MULLION 'M3'	MULLION 'M4'
WIDTH (W)	FRAME HEIGHT	EXT.(+)/INT.(-)	EXT.(+)/INT.(-)	EXT.(+)/INT.(-)	EXT.(+)/INT.(-)
24"	60"	100.0	100.0	100.0	100.0
30"		100.0	100.0	100.0	100.0
36"		100.0	100.0	100.0	100.0
42"		100.0	100.0	100.0	100.0
48"		100.0	100.0	100.0	100.0
54"		100.0	100.0	100.0	100.0
60"		100.0	100.0	100.0	100.0
66"		100.0	100.0	100.0	100.0
72"	100.0	100.0	100.0	100.0	
24"	66"	100.0	100.0	100.0	100.0
30"		100.0	100.0	100.0	100.0
36"		100.0	100.0	100.0	100.0
42"		100.0	100.0	100.0	100.0
48"		100.0	100.0	100.0	100.0
54"		100.0	100.0	100.0	100.0
60"		100.0	100.0	100.0	100.0
66"		100.0	100.0	100.0	100.0
72"	-	-	100.0	100.0	
24"	72"	100.0	100.0	100.0	100.0
30"		100.0	100.0	100.0	100.0
36"		100.0	100.0	100.0	100.0
42"		100.0	100.0	100.0	100.0
48"		100.0	100.0	100.0	100.0
54"		95.9	99.0	100.0	100.0
60"		91.3	94.3	100.0	100.0
66"		-	-	100.0	100.0
72"	-	-	100.0	100.0	
24"	78"	100.0	100.0	100.0	100.0
30"		100.0	100.0	100.0	100.0
36"		100.0	100.0	100.0	100.0
42"		93.4	96.7	100.0	100.0
48"		84.5	87.5	100.0	100.0
54"		78.2	81.0	100.0	100.0
60"		-	-	100.0	100.0
66"		-	-	100.0	100.0
72"	-	-	100.0	100.0	
24"	84"	100.0	100.0	100.0	100.0
30"		100.0	100.0	100.0	100.0
36"		89.7	93.1	100.0	100.0
42"		78.7	81.7	100.0	100.0
48"		70.8	73.5	100.0	100.0
54"		65.1	67.5	100.0	100.0
60"		-	-	100.0	100.0
66"		-	-	98.6	98.0
24"	90"	100.0	100.0	100.0	100.0
30"		90.6	90.3	100.0	100.0
36"		76.8	76.8	100.0	100.0
42"		67.2	67.4	100.0	100.0
48"		60.2	60.7	100.0	100.0
54"		-	-	94.6	94.0
60"		-	-	88.0	87.4

MULLION LOAD CAPACITY - PSF WITHOUT INTERMEDIATE HORIZONTALS					
NOMINAL DIMS.		MULLION 'M1'	MULLION 'M2'	MULLION 'M3'	MULLION 'M4'
WIDTH (W)	FRAME HEIGHT	EXT.(+)/INT.(-)	EXT.(+)/INT.(-)	EXT.(+)/INT.(-)	EXT.(+)/INT.(-)
24"	96"	92.9	91.2	100.0	100.0
30"		75.4	74.0	100.0	100.0
36"		63.9	62.8	100.0	100.0
42"		56.0	55.0	100.0	99.9
48"		50.2	49.3	89.8	89.2
54"		-	-	81.8	81.3
60"		-	-	75.7	75.2
24"		97-3/4"	87.9	86.3	100.0
30"	71.3		70.0	100.0	100.0
36"	60.4		59.3	100.0	100.0
42"	52.9		51.9	96.7	96.1
45"	49.9		49.0	91.2	90.6
46-1/2"	48.6		47.7	88.7	88.1
48"	-		-	86.3	85.8
54"	-		-	78.6	78.1
60"	-	-	72.7	72.2	
24"	102"	-	-	100.0	100.0
30"		-	-	100.0	100.0
36"		-	-	100.0	100.0
42"		-	-	88.4	87.8
48"		-	-	78.7	78.2
54"	-	-	71.5	71.0	
24"	108"	-	-	100.0	100.0
30"		-	-	100.0	100.0
36"		-	-	90.2	89.6
42"		-	-	78.3	77.8
48"		-	-	69.7	69.2
54"	-	-	63.1	62.7	
24"	114"	-	-	100.0	100.0
30"		-	-	95.8	95.2
36"		-	-	80.6	80.1
42"		-	-	69.9	69.5
48"	-	-	62.1	61.7	
24"	120"	-	-	100.0	100.0
30"		-	-	86.3	85.7
36"		-	-	72.5	72.1
42"		-	-	62.8	62.4
48"	-	-	55.7	55.3	

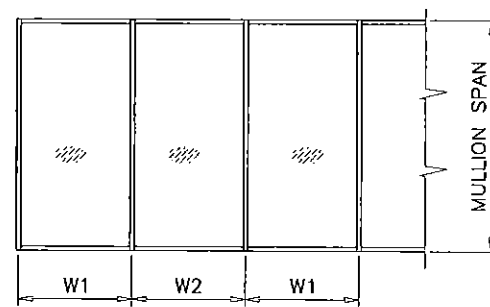

$$WIDTH (W) = \frac{W1 + W2}{2}$$

LOADS SHOWN IN CHARTS ARE FOR INSTALLATIONS WHERE WATER INFILTRATION RESISTANCE IS NOT REQUIRED. LIMIT EXTERIOR LOADS TO +60.0 PSF FOR INSTALLATIONS WHERE WATER INFILTRATION RESISTANCE IS REQUIRED.

NOTE: INTERPOLATION BETWEEN WIDTHS OR HEIGHTS ALLOWED.

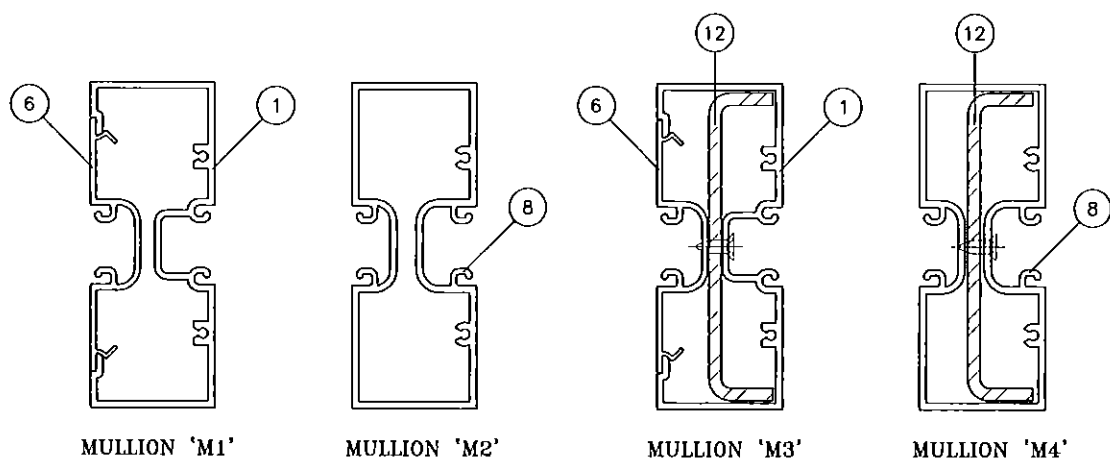

Engr: JAVAD AHMAD  
 CIVIL  
 FLA. PE # 70592  
 C.A.N. 3538  
 MAR 11 2015

PRODUCT REVISED  
 as complying with the Florida  
 Building Code  
 Acceptance No 15-0401.01  
 Expiration Date Oct 6, 2016  
 By *Manuel Per*  
 Miami Dade Product Control

**af c**  
**AL-FAROOQ CORPORATION**  
 ENGINEERS & PRODUCT DEVELOPMENT  
 1235 S.W. 87 AVE  
 MIAMI, FLORIDA 33174  
 TEL. (305) 264-8100 FAX. (305) 262-6978  
 COMP-ANL\W10-75MRG

---

MG-4500 ALUMINUM FLUSH GLAZED SYSTEM (N.I.)  
**MR. GLASS DOORS & WINDOWS INC.**  
 7440 N.W. 66 STREET  
 MIAMI, FL. 33166  
 TEL. (305) 470-8284 FAX. (305) 470-8285

---

no	date	description
A	08.14.11	NO CHANGE THIS SHEET
B	03.04.15	UPDATED TO 2014 FBC

---

date: 10-15-10  
 scale: 3/8" = 1"  
 dr. by: HAMID  
 chk. by:

---

drawing no.  
**W10-75**

---

sheet 3 of 9

MULLION LOAD CAPACITY - PSF WITH INTERMEDIATE HORIZONTALS					
NOMINAL DIMS.		MULLION 'M1'	MULLION 'M2'	MULLION 'M3'	MULLION 'M4'
WIDTH (W)	FRAME HEIGHT	EXT.(+)/INT.(-)	EXT.(+)/INT.(-)	EXT.(+)/INT.(-)	EXT.(+)/INT.(-)
24"	60"	100.0	100.0	100.0	100.0
30"		100.0	100.0	100.0	100.0
36"		100.0	100.0	100.0	100.0
42"		100.0	100.0	100.0	100.0
48"		100.0	100.0	100.0	100.0
54"		100.0	100.0	100.0	100.0
60"		100.0	100.0	100.0	100.0
66"		93.7	96.3	100.0	100.0
72"	85.9	88.2	100.0	100.0	
24"	66"	100.0	100.0	100.0	100.0
30"		100.0	100.0	100.0	100.0
36"		100.0	100.0	100.0	100.0
42"		100.0	100.0	100.0	100.0
48"		100.0	100.0	100.0	100.0
54"		93.7	96.5	100.0	100.0
60"		84.3	86.9	100.0	100.0
66"		76.6	79.0	100.0	100.0
72"	-	-	100.0	100.0	
24"	72"	100.0	100.0	100.0	100.0
30"		100.0	100.0	100.0	100.0
36"		100.0	100.0	100.0	100.0
42"		100.0	100.0	100.0	100.0
48"		87.7	90.6	100.0	100.0
54"		78.0	80.5	100.0	100.0
60"		70.2	72.5	100.0	100.0
66"		-	-	100.0	100.0
72"	-	-	97.8	97.2	
24"	78"	100.0	100.0	100.0	100.0
30"		100.0	100.0	100.0	100.0
36"		98.7	100.0	100.0	100.0
42"		84.6	87.6	100.0	100.0
48"		74.0	76.6	100.0	100.0
54"		65.8	68.1	100.0	100.0
60"		-	-	100.0	99.3
66"		-	-	90.9	90.3
72"	-	-	83.3	82.8	
24"	84"	100.0	100.0	100.0	100.0
30"		100.0	100.0	100.0	100.0
36"		84.6	87.7	100.0	100.0
42"		72.5	75.2	100.0	100.0
48"		63.4	65.8	100.0	100.0
54"		56.4	58.5	95.8	95.2
60"		-	-	86.2	85.7
66"		-	-	78.4	77.9
24"	90"	100.0	100.0	100.0	100.0
30"		88.2	86.5	100.0	100.0
36"		73.5	72.1	100.0	100.0
42"		63.0	61.8	100.0	100.0
48"		55.1	54.1	93.9	93.3
54"		-	-	83.4	82.9
60"		-	-	75.1	74.6

MULLION LOAD CAPACITY - PSF WITH INTERMEDIATE HORIZONTALS					
NOMINAL DIMS.		MULLION 'M1'	MULLION 'M2'	MULLION 'M3'	MULLION 'M4'
WIDTH (W)	FRAME HEIGHT	EXT.(+)/INT.(-)	EXT.(+)/INT.(-)	EXT.(+)/INT.(-)	EXT.(+)/INT.(-)
24"	96"	90.8	89.1	100.0	100.0
30"		72.6	71.3	100.0	100.0
36"		60.5	59.4	100.0	100.0
42"		51.9	50.9	94.3	93.7
48"		45.4	44.6	82.5	82.0
54"		-	-	73.3	72.9
60"		-	-	66.0	65.6
24"		97-3/4"	86.0	84.4	100.0
30"	68.8		67.5	100.0	100.0
36"	57.3		56.3	100.0	100.0
42"	49.2		48.2	90.9	90.4
45"	45.9		45.0	84.9	84.3
46-1/2"	44.4		43.6	82.1	81.6
48"	-		-	79.6	79.1
54"	-		-	70.7	70.3
60"	-	-	63.7	63.3	
24"	102"	-	-	100.0	100.0
30"		-	-	100.0	100.0
36"		-	-	97.4	96.8
42"		-	-	83.5	83.0
48"		-	-	73.1	72.6
54"	-	-	65.0	64.5	
24"	108"	-	-	100.0	100.0
30"		-	-	100.0	100.0
36"		-	-	86.9	86.4
42"		-	-	74.5	74.0
48"		-	-	65.2	64.8
54"	-	-	57.9	57.6	
24"	114"	-	-	100.0	100.0
30"		-	-	93.6	93.0
36"		-	-	78.0	77.5
42"		-	-	66.9	66.4
48"		-	-	58.5	58.1
24"	120"	-	-	100.0	100.0
30"		-	-	84.5	83.9
36"		-	-	70.4	70.0
42"		-	-	60.3	60.0
48"		-	-	52.8	52.5

LOADS SHOWN IN CHARTS ARE FOR INSTALLATIONS WHERE WATER INFILTRATION RESISTANCE IS NOT REQUIRED. LIMIT EXTERIOR LOADS TO +60.0 PSF FOR INSTALLATIONS WHERE WATER INFILTRATION RESISTANCE IS REQUIRED.

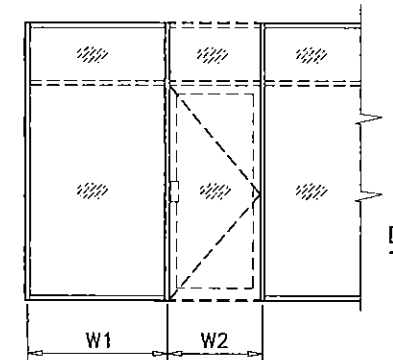
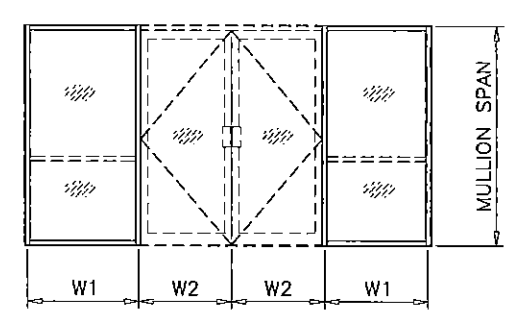
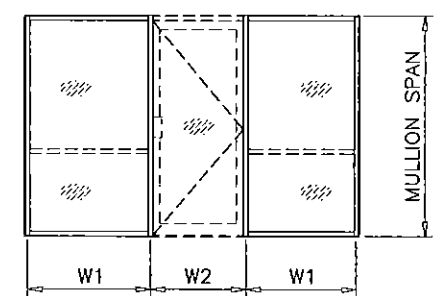
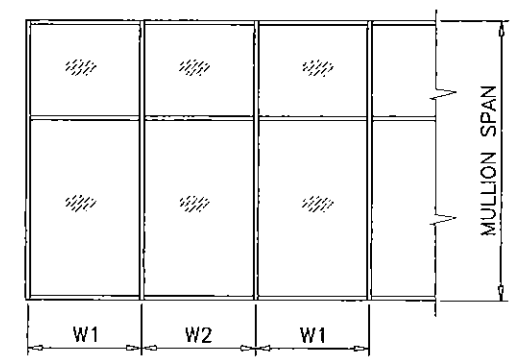

$$\text{WIDTH (W)} = \frac{W1 + W2}{2}$$

DOORS NOT PART OF THIS NOA.

NOTE: INTERPOLATION BETWEEN WIDTHS OR HEIGHTS ALLOWED.

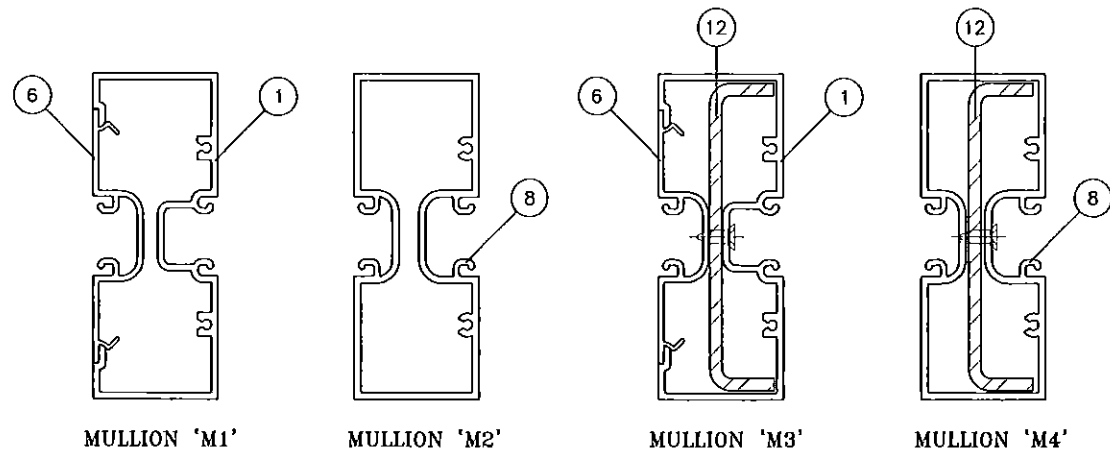

Engr: JAVAD AHMAD  
CIVIL  
FLA. PE # 20592  
C.A.N. 3538

MAR 11 2015

PRODUCT REVISED  
as complying with the Florida  
Building Code  
Acceptance No. 15-0401.01  
Expiration Date Oct 6, 2016

By *Manuel Perez*  
Miami Dade Product Control

**af c**

**AL-FAROOQ CORPORATION**  
ENGINEERS & PRODUCT DEVELOPMENT  
1235 S.W. 87 AVE  
MIAMI, FLORIDA 33174  
TEL. (305) 264-8100 FAX. (305) 262-6978  
COMP-ANL\W10-75MRG

MG-4500 ALUMINUM FLUSH GLAZED SYSTEM (N.I.)

**MR. GLASS DOORS & WINDOWS INC.**  
7440 N.W. 66 STREET  
MIAMI, FL. 33166  
TEL. (305) 470-8284 FAX. (305) 470-8285

no	date	description
A	09.14.11	REV. PER BNC COMMENTS
B	03.04.15	UPDATED TO 2014 FBC

date: 10-15-10  
scale: 3/8" = 1"  
dr. by: HAMID  
chk. by:

drawing no.  
**W10-75**

sheet 4 of 9

ANCHOR LOAD CAPACITY - PSF EXT.(+) & INT.(-)								
NOMINAL DIMS.		ANCHOR TYPE 'A'			ANCHOR TYPE 'B'		ANCHOR TYPE 'C'	
WIDTH (W)	FRAME HEIGHT	A2	A3	A4	B2	B3	C2	C3
24"	60"	100.0	100.0	100.0	100.0	100.0	100.0	100.0
30"		100.0	100.0	100.0	100.0	100.0	100.0	100.0
36"		100.0	100.0	100.0	100.0	100.0	100.0	100.0
42"		90.1	100.0	100.0	100.0	100.0	100.0	100.0
48"		78.8	100.0	100.0	100.0	100.0	100.0	100.0
54"		70.0	100.0	100.0	100.0	100.0	100.0	100.0
60"		63.0	94.6	100.0	100.0	100.0	100.0	100.0
66"		57.3	86.0	100.0	100.0	100.0	100.0	100.0
72"	52.5	78.8	100.0	96.0	100.0	100.0	100.0	
24"	66"	100.0	100.0	100.0	100.0	100.0	100.0	100.0
30"		100.0	100.0	100.0	100.0	100.0	100.0	100.0
36"		95.5	100.0	100.0	100.0	100.0	100.0	100.0
42"		81.9	100.0	100.0	100.0	100.0	100.0	100.0
48"		71.6	100.0	100.0	100.0	100.0	100.0	100.0
54"		63.7	95.5	100.0	100.0	100.0	100.0	100.0
60"		57.3	86.0	100.0	100.0	100.0	100.0	100.0
66"		52.1	78.1	100.0	95.2	100.0	100.0	100.0
72"	47.8	71.6	95.5	87.3	100.0	92.8	100.0	
24"	72"	100.0	100.0	100.0	100.0	100.0	100.0	100.0
30"		100.0	100.0	100.0	100.0	100.0	100.0	100.0
36"		87.6	100.0	100.0	100.0	100.0	100.0	100.0
42"		75.0	100.0	100.0	100.0	100.0	100.0	100.0
48"		65.7	98.5	100.0	100.0	100.0	100.0	100.0
54"		58.4	87.6	100.0	100.0	100.0	100.0	100.0
60"		52.5	78.8	100.0	96.0	100.0	100.0	100.0
66"		47.8	71.6	95.5	87.3	100.0	92.8	100.0
72"	43.8	65.7	87.6	80.0	100.0	85.1	100.0	
24"	78"	100.0	100.0	100.0	100.0	100.0	100.0	100.0
30"		97.0	100.0	100.0	100.0	100.0	100.0	100.0
36"		80.8	100.0	100.0	100.0	100.0	100.0	100.0
42"		69.3	100.0	100.0	100.0	100.0	100.0	100.0
48"		60.6	90.9	100.0	100.0	100.0	100.0	100.0
54"		53.9	80.8	100.0	98.5	100.0	100.0	100.0
60"		48.5	72.7	97.0	88.6	100.0	94.3	100.0
66"		44.1	66.1	88.2	80.6	100.0	85.7	100.0
72"	40.4	60.6	80.8	73.8	100.0	78.6	100.0	
24"	84"	100.0	100.0	100.0	100.0	100.0	100.0	100.0
30"		90.1	100.0	100.0	100.0	100.0	100.0	100.0
36"		75.0	100.0	100.0	100.0	100.0	100.0	100.0
42"		64.3	96.5	100.0	100.0	100.0	100.0	100.0
48"		56.3	84.4	100.0	100.0	100.0	100.0	100.0
54"		50.0	75.0	100.0	91.4	100.0	97.3	100.0
60"		45.0	67.5	90.1	82.3	100.0	87.5	100.0
66"		40.9	61.4	81.9	74.8	100.0	79.6	100.0
24"	96"	98.5	100.0	100.0	100.0	100.0	100.0	100.0
30"		78.8	100.0	100.0	100.0	100.0	100.0	100.0
36"		65.7	98.5	100.0	100.0	100.0	100.0	100.0
42"		56.3	84.4	100.0	100.0	100.0	100.0	100.0
48"		49.3	73.9	98.5	90.0	100.0	95.8	100.0
54"		43.8	65.7	87.6	80.0	100.0	85.1	100.0
60"		39.4	59.1	78.8	72.0	100.0	76.6	100.0

ANCHOR LOAD CAPACITY - PSF EXT.(+) & INT.(-)								
NOMINAL DIMS.		ANCHOR TYPE 'A'			ANCHOR TYPE 'B'		ANCHOR TYPE 'C'	
WIDTH (W)	FRAME HEIGHT	A2	A3	A4	B2	B3	C2	C3
24"	97-3/4"	96.7	100.0	100.0	100.0	100.0	100.0	100.0
30"		77.4	100.0	100.0	100.0	100.0	100.0	100.0
36"		64.5	96.7	100.0	100.0	100.0	100.0	100.0
42"		55.3	82.9	100.0	100.0	100.0	100.0	100.0
48"		48.4	72.6	96.7	88.4	100.0	94.0	100.0
54"		43.0	64.5	86.0	78.6	100.0	83.6	100.0
60"		38.7	58.0	77.4	70.7	100.0	75.2	100.0
24"		102"	92.7	100.0	100.0	100.0	100.0	100.0
30"	74.2		100.0	100.0	100.0	100.0	100.0	100.0
36"	61.8		92.7	100.0	100.0	100.0	100.0	100.0
42"	53.0		79.5	100.0	96.8	100.0	100.0	100.0
48"	46.4		69.5	92.7	84.7	100.0	90.1	100.0
54"	41.2	61.8	82.4	75.3	100.0	80.1	100.0	
24"	108"	87.6	100.0	100.0	100.0	100.0	100.0	100.0
30"		70.0	100.0	100.0	100.0	100.0	100.0	100.0
36"		58.4	87.6	100.0	100.0	100.0	100.0	100.0
42"		50.0	75.0	100.0	91.4	100.0	97.3	100.0
48"		43.8	65.7	87.6	80.0	100.0	85.1	100.0
54"	38.9	58.4	77.8	71.1	100.0	75.7	100.0	
24"	114"	82.9	100.0	100.0	100.0	100.0	100.0	100.0
30"		66.4	99.5	100.0	100.0	100.0	100.0	100.0
36"		55.3	82.9	100.0	100.0	100.0	100.0	100.0
42"		47.4	71.1	94.8	86.6	100.0	92.2	100.0
48"		41.5	62.2	82.9	75.8	100.0	80.6	100.0
24"	120"	78.8	100.0	100.0	100.0	100.0	100.0	100.0
30"		63.0	94.6	100.0	100.0	100.0	100.0	100.0
36"		52.5	78.8	100.0	96.0	100.0	100.0	100.0
42"		45.0	67.5	90.1	82.3	100.0	87.5	100.0
48"		39.4	59.1	78.8	72.0	108.0	76.6	100.0

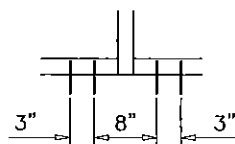

A2, B2, C2

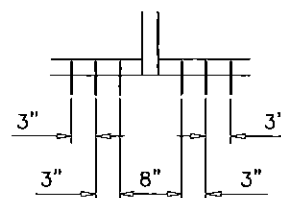

A3, B3, C3

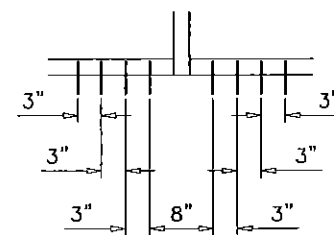

A4

ANCHORS TYPES: SEE SHEET 7 FOR DESCRIPTION

- A2 = (2) ANCHORS TYPE 'A' AT EACH SIDE OF MULLION
- A3 = (3) ANCHORS TYPE 'A' AT EACH SIDE OF MULLION
- A4 = (4) ANCHORS TYPE 'A' AT EACH SIDE OF MULLION
- B2 = (2) ANCHORS TYPE 'B' AT EACH SIDE OF MULLION
- B3 = (3) ANCHORS TYPE 'B' AT EACH SIDE OF MULLION
- C2 = (2) ANCHORS TYPE 'C' AT EACH SIDE OF MULLION

ALL OTHER ANCHORS TO BE SPACED AS PER ELEVATION.

NOTE: INTERPOLATION BETWEEN WIDTHS OR HEIGHTS ALLOWED.

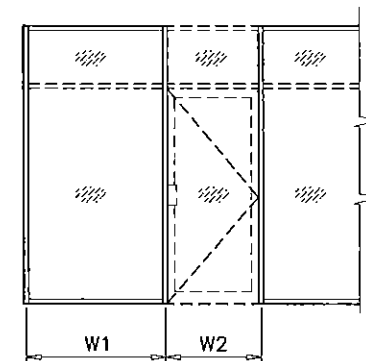
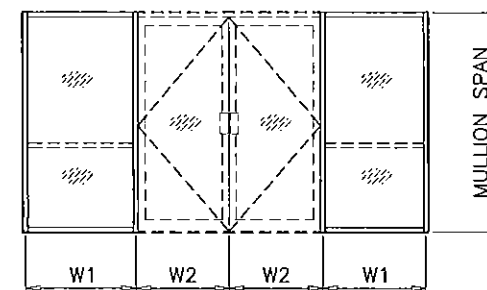
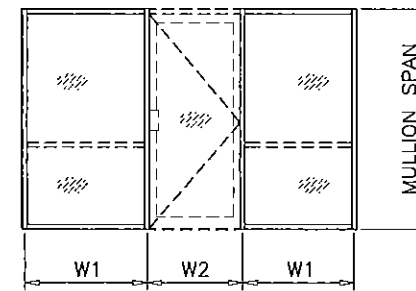
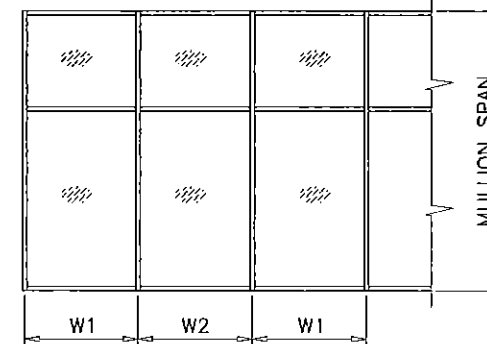

$$\text{WIDTH (W)} = \frac{W1 + W2}{2}$$

DOORS NOT PART OF THIS NOA.

ANCHORS

Engr: JAVAD AHMAD  
CIVIL  
FLA. PE # 70592  
C.A.N. 3538  
MAR 11 2015

PRODUCT REVISED  
as complying with the Florida  
Building Code  
Acceptance No. 15-0401.01  
Expiration Date Oct. 6, 2016  
By Manuel Perez  
Miami Dade Product Council

**afC**  
**AL-FAROOQ CORPORATION**  
ENGINEERS & PRODUCT DEVELOPMENT  
1235 S.W. 87 AVE  
MIAMI, FLORIDA 33174  
TEL. (305) 264-8100 FAX. (305) 262-6978  
COMP-ANL\W10-75MRG

MG-4500 ALUMINUM FLUSH GLAZED SYSTEM (N.I.)  
**MR. GLASS DOORS & WINDOWS INC.**  
7440 N.W. 66 STREET  
MIAMI, FL. 33166  
TEL. (305) 470-8284 FAX. (305) 470-8285

NO	DATE	DESCRIPTION
A	09.14.11	REV. PER BNC COMMENTS
B	03.04.15	UPDATED TO 2014 FBC

date: 10-15-10  
scale: 3/8" = 1"  
dr. by: HAMID  
chk. by:

drawing no. W10-75  
sheet 5 of 9



DOOR MULLION LOAD CAPACITY - PSF				
NOMINAL DIMS.				DOOR MULLION
FRAME HEIGHT INCHES	DOOR HEIGHT INCHES	WIDTH (W1) INCHES	WIDTH (W2) INCHES	EXT. (+) INT. (-)
96	84	72	18	100.0
			24	100.0
			30	100.0
			36	97.5
			42	90.8
102	84	72	18	100.0
			24	95.6
			30	88.5
			36	82.3
			42	76.9
108	84	72	18	87.9
			24	81.2
			30	75.5
			36	70.4
			42	66.0
114	84	72	18	75.3
			24	69.8
			30	65.1
			36	60.9
			42	57.3
120	84	72	18	65.2
			24	60.7
			30	56.7
			36	53.2
			42	50.1

DOOR MULLION LOAD CAPACITY - PSF				
NOMINAL DIMS.				DOOR MULLION
FRAME HEIGHT INCHES	DOOR HEIGHT INCHES	WIDTH (W1) INCHES	WIDTH (W2) INCHES	EXT. (+) INT. (-)
96	90	72	18	100.0
			24	100.0
			30	100.0
			36	100.0
			42	95.9
102	90	72	18	100.0
			24	100.0
			30	93.9
			36	86.9
			42	81.0
108	90	72	18	93.9
			24	86.2
			30	79.7
			36	74.1
			42	69.2
114	90	72	18	80.0
			24	73.8
			30	68.5
			36	63.9
			42	59.8
120	90	72	18	69.0
			24	63.9
			30	59.5
			36	55.6
			42	52.2

DOOR MULLION LOAD CAPACITY - PSF				
NOMINAL DIMS.				DOOR MULLION
FRAME HEIGHT INCHES	DOOR HEIGHT INCHES	WIDTH (W1) INCHES	WIDTH (W2) INCHES	EXT. (+) INT. (-)
102	96	72	18	100.0
			24	100.0
			30	99.9
			36	92.0
			42	85.3
108	96	72	18	100.0
			24	91.7
			30	84.3
			36	78.0
			42	72.6
114	96	72	18	85.2
			24	78.1
			30	72.2
			36	67.0
			42	62.6
120	96	72	18	73.1
			24	67.4
			30	62.5
			36	58.2
			42	54.5

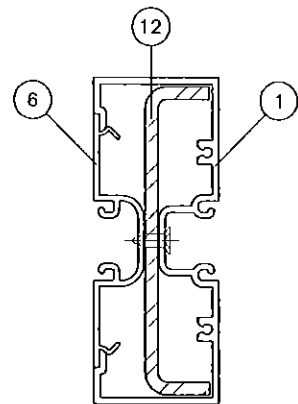

DOOR MULLION WITH REINFORCING

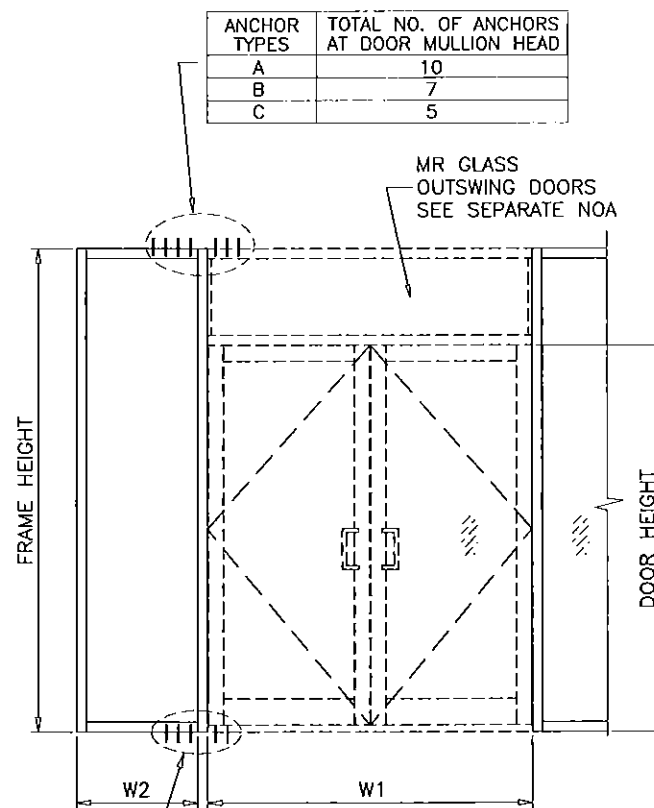

DOOR MULLION

Engr: JAVAD AHMAD  
 CIVIL  
 FLA. PE # 70592  
 C.A.N. # 3538  
 MAR 11 2015

PRODUCT REVISED as complying with the Florida Building Code  
 Acceptance No 15-0401.01  
 Expiration Date Oct. 16, 2016  
 By: *Manuel Juez*  
 Miami Dade Product Control

**afC**  
**AL-FAROOQ CORPORATION**  
 ENGINEERS & PRODUCT DEVELOPMENT  
 1235 S.W. 87 AVE  
 MIAMI, FLORIDA 33174  
 TEL. (305) 264-8100 FAX. (305) 262-6978  
 COMP-ANL\W10-75MRC

MG-4500 ALUMINUM FLUSH GLAZED SYSTEM (N.I.)  
**MR. GLASS DOORS & WINDOWS INC.**  
 7440 N.W. 66 STREET  
 MIAMI, FL. 33166  
 TEL. (305) 470-8284 FAX. (305) 470-8285

NO	DATE	DESCRIPTION
A	09.14.11	NO CHANGE THIS SHEET
B	03.04.15	UPDATED TO 2014 FBC

date: 10-15-10  
 scale: 3/8" = 1"  
 dr. by: HAMID  
 chk. by:

drawing no. W10-75  
 sheet 6 of 9

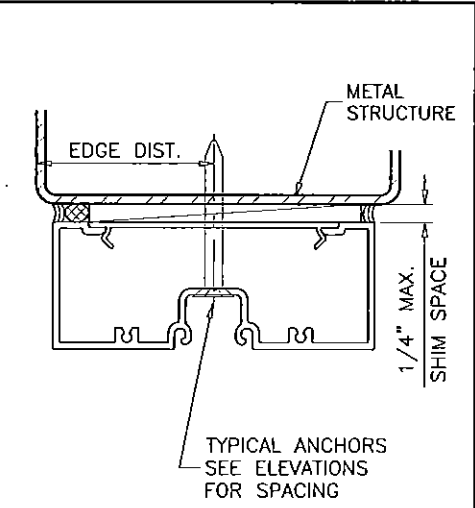
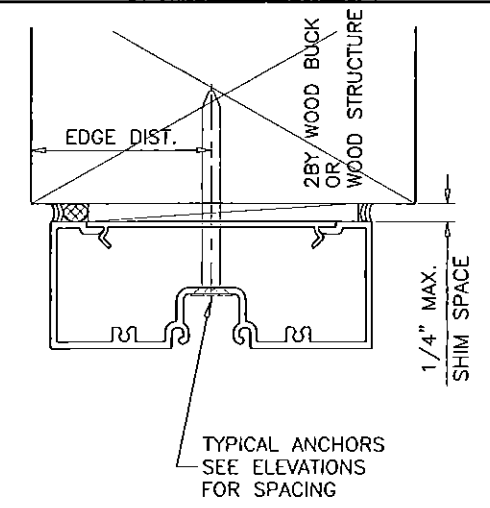
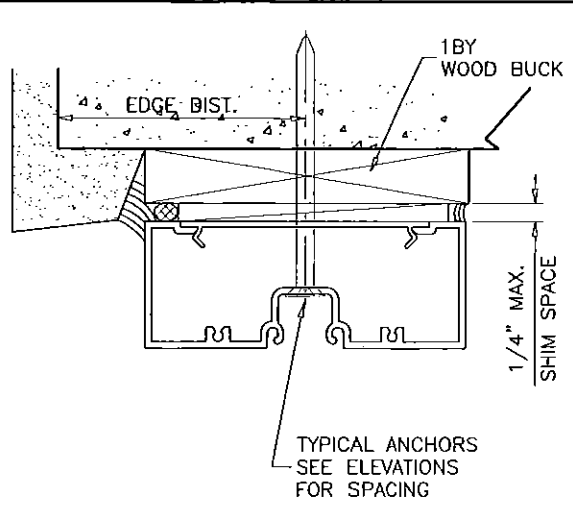
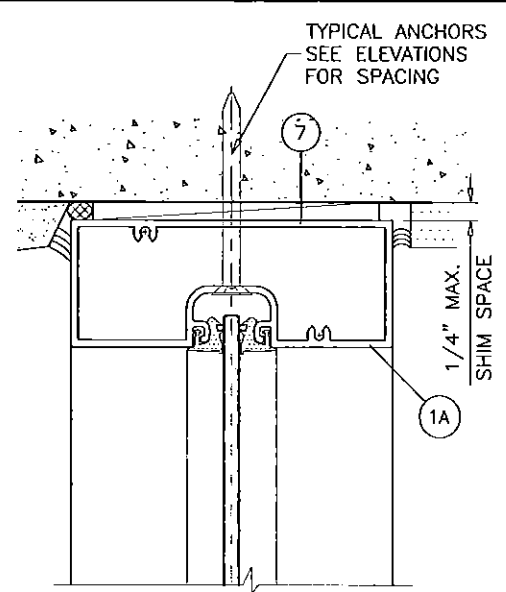
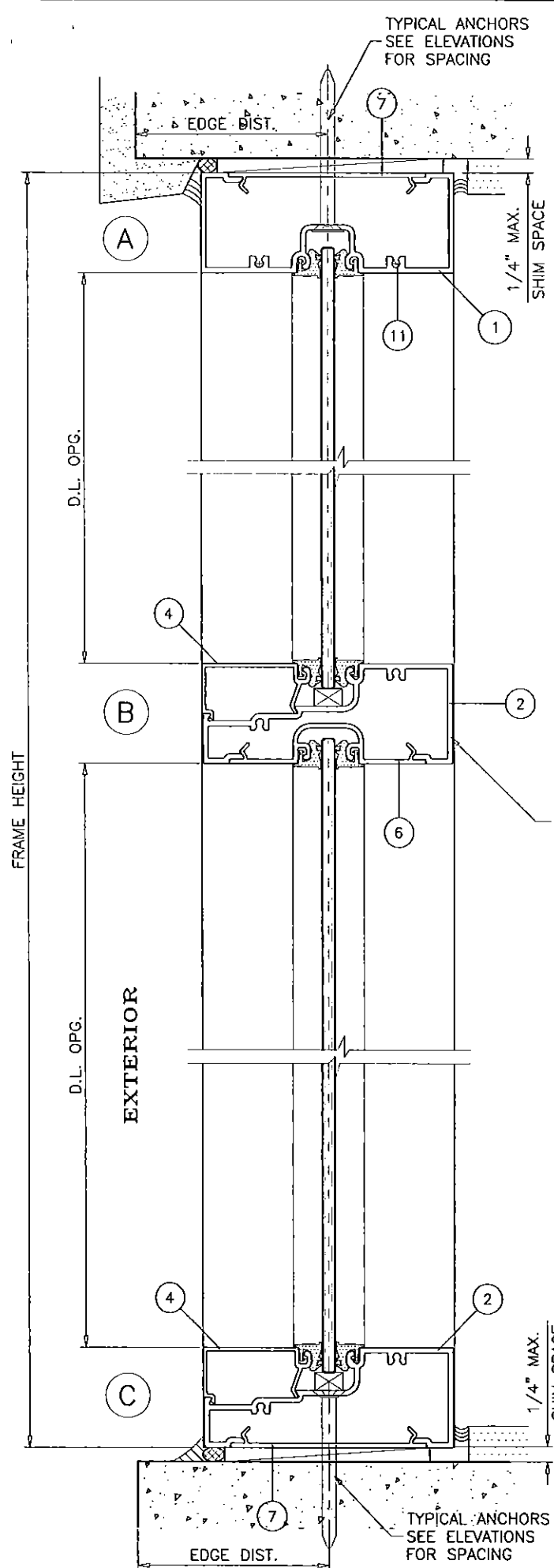

LIMIT MAX. DESIGN LOADS FOR HORIZONTAL AS FOLLOWS

HORIZ. SPAN MAX.	LOADS
70-1/4"	58.2 PSF
64-1/4"	76.9 PSF
58-1/4"	100.0 PSF
52-1/4"	100.0 PSF

WOOD BUCKS AND METAL STRUCTURE NOT BY MR. GLASS MUST SUSTAIN LOADS IMPOSED BY GLAZING SYSTEM AND TRANSFER THEM TO THE BUILDING STRUCTURE.

TYPICAL ANCHORS: SEE ELEV. FOR SPACING

TYPE 'A'- 1/4" DIA ULTRACON BY 'ELCO' (Fu=177 KSI, Fy=155 KSI) INTO 2BY WOOD BUCKS OR WOOD STRUCTURES WITH 1-1/2" MIN. PENETRATION INTO WOOD THRU 1BY WOOD BUCKS INTO CONCRETE OR MASONRY WITH 1-1/4" MIN. EMBED INTO CONCRETE OR MASONRY

ANCHOR EDGE DISTANCES INTO CONCRETE OR MASONRY = 2-1/2" MIN. INTO WOOD STRUCTURE = 1" MIN.

TYPE 'B'- 1/4" DIA ULTRACON BY 'ELCO' (Fu=177 KSI, Fy=155 KSI) DIRECTLY INTO CONCRETE OR MASONRY WITH 1-1/4" MIN. EMBED INTO CONCRETE OR MASONRY

ANCHOR EDGE DISTANCES INTO CONCRETE AND MASONRY = 2-1/2" MIN.

TYPE 'C'- #14 SMS OR SELF DRILLING SCREWS ST/ST (GRADE 2 CRS) INTO MIAMI-DADE COUNTY APPROVED MULLIONS (1/8" THK. MIN.) INTO METAL STRUCTURES STEEL : 1/8" THK. MIN. (Fy = 36 KSI MIN.) ALUMINUM : 1/8" THK. MIN. (6063-T5 MIN.) (STEEL IN CONTACT WITH ALUMINUM TO BE PLATED OR PAINTED)

ANCHOR EDGE DISTANCES INTO METAL STRUCTURE = 3/4" MIN.

WOOD AT HEAD, SILL OR JAMBS SG = 0.55 MIN.  
 CONCRETE AT HEAD, SILL OR JAMBS f'c = 3000 PSI MIN.  
 C-90 HOLLOW/FILLED BLOCK AT JAMBS f'm = 2000 PSI MIN.

Engr: JAVAD AHMAD  
 CIVIL  
 FLA. PE # 70592  
 C.A.N. # 538  
 MAR 11 2015

PRODUCT REVISED as complying with the Florida Building Code  
 Acceptance No 15-041.01  
 Expiration Date Oct 6, 2016  
 By *Wahmed Jaz*  
 Miami Dade Product Control

**af c**  
**AL-FAROOQ CORPORATION**  
 ENGINEERS & PRODUCT DEVELOPMENT  
 1235 S.W. 87 AVE  
 MIAMI, FLORIDA 33174  
 TEL. (305) 264-8100 FAX. (305) 262-6978  
 COMP-ANL\W10-75MFG

MG-4500 ALUMINUM FLUSH GLAZED SYSTEM (N.I.)  
**MR. GLASS DOORS & WINDOWS INC.**  
 7440 N.W. 66 STREET  
 MIAMI, FL. 33166  
 TEL. (305) 470-8284 FAX. (305) 470-8285

revisions:	no	date	by	description
	A	09.14.11		REV. PER BNC COMMENTS
	B	03.04.15		UPDATED TO 2014 FBC

date:	10-15-10
scale:	3/8" = 1"
dr. by:	HAMID
chk. by:	

drawing no.	W10-75
sheet	7 of 9



#12 X 1/2" FH SCREWS  
(GRADE 2 CRS)  
(Fu=92 KSI, FY=57 KSI)  
AT 11" O.C.

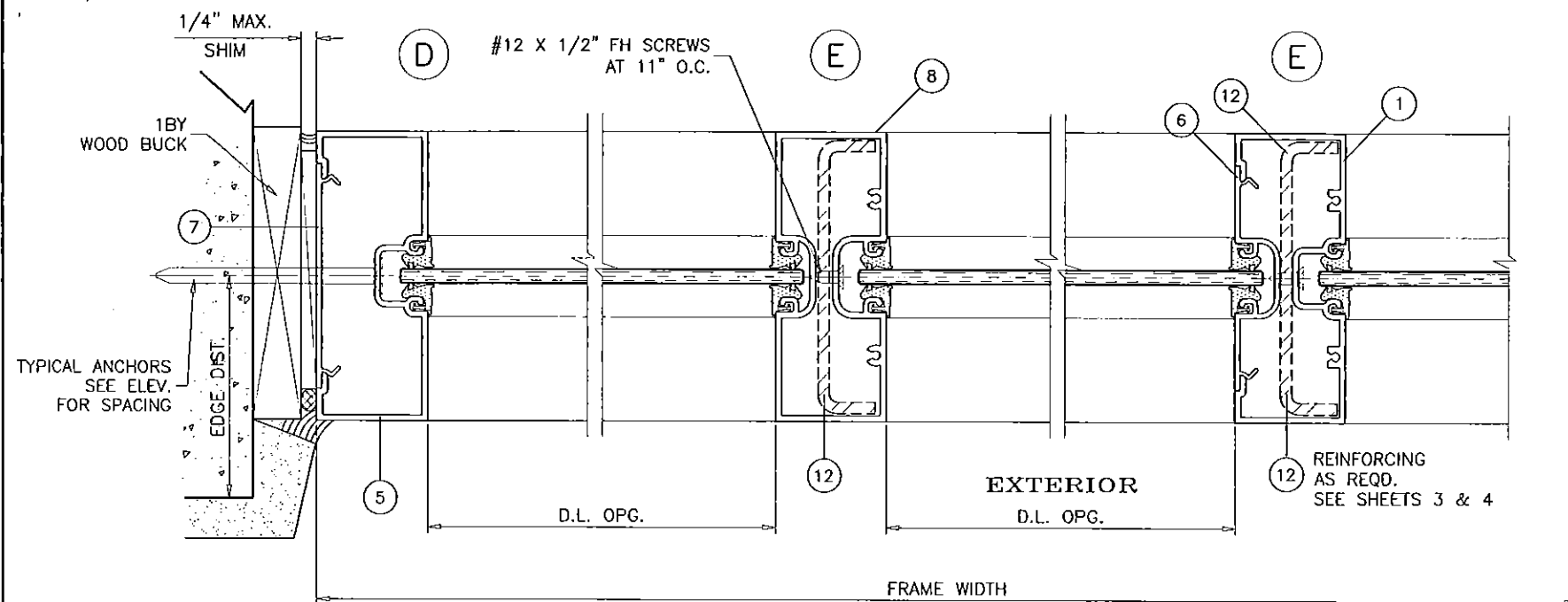

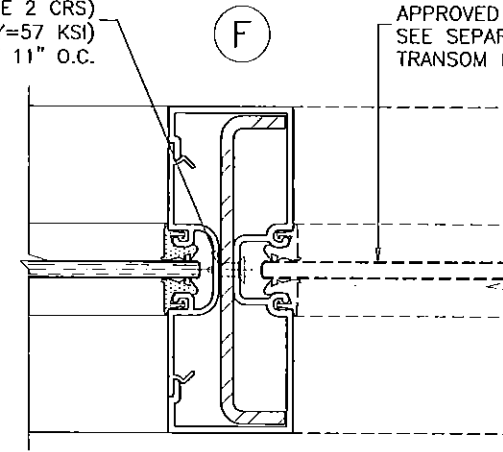
MIAMI-DADE COUNTY  
APPROVED TRANSOM  
SEE SEPARATE NOA FOR  
TRANSOM RATING AND DETAILS

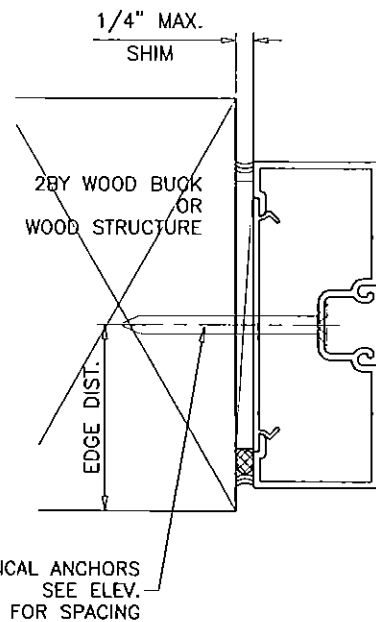
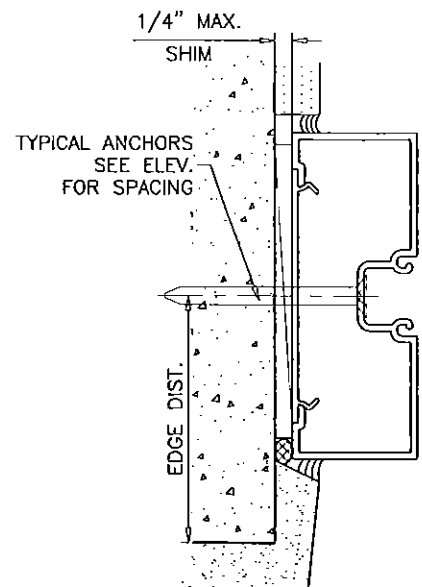
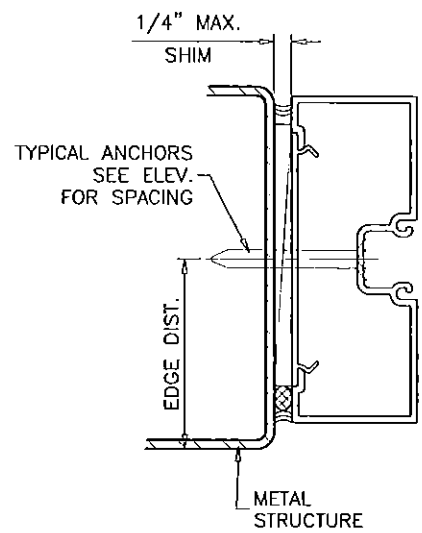

DOOR MULLION  
SEE SHEET 6  
FOR CAPACITY

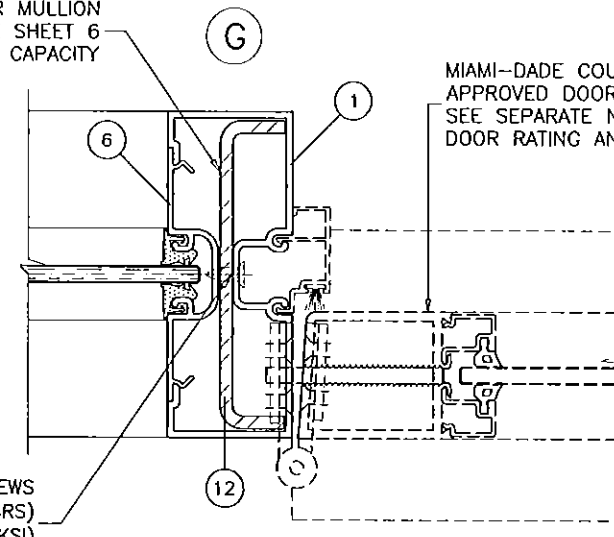

MIAMI-DADE COUNTY  
APPROVED DOOR  
SEE SEPARATE NOA FOR  
DOOR RATING AND DETAILS

#12 X 1/2" FH SCREWS  
(GRADE 2 CRS)  
(Fu=92 KSI, FY=57 KSI)  
AT 11" O.C.

Engr: JAVAD AHMAD  
CIVIL  
FLA. PE # 70592  
C.A.N. 3538

MAR 11 2015

PRODUCT REVISED  
as complying with the Florida  
Building Code  
Acceptance No 15-0401.01  
Expiration Date Oct 6, 2016  
By *Manuel Perez*  
Miami Dade Product Control

**af c**  
**AL-FAROOQ CORPORATION**  
ENGINEERS & PRODUCT DEVELOPMENT  
1235 S.W. 87 AVE  
MIAMI, FLORIDA 33174  
TEL (305) 264-8100 FAX (305) 262-6978  
COMP - ANL \ W10 - 75MRG

MG-4500 ALUMINUM FLUSH GLAZED SYSTEM (N.I.)  
**MR. GLASS DOORS & WINDOWS INC.**  
7440 N.W. 66 STREET  
MIAMI, FL. 33166  
TEL. (305) 470-8284 FAX. (305) 470-8285

no	date	description	by
A	08.14.11	REV. PER BNC COMMENTS	
B	03.04.15	NO CHANGE THIS SHEET	

date: 10-15-10  
scale: 3/8" = 1"  
dr. by: HAMID  
chk. by:

drawing no.  
**W10-75**  
sheet 8 of 9

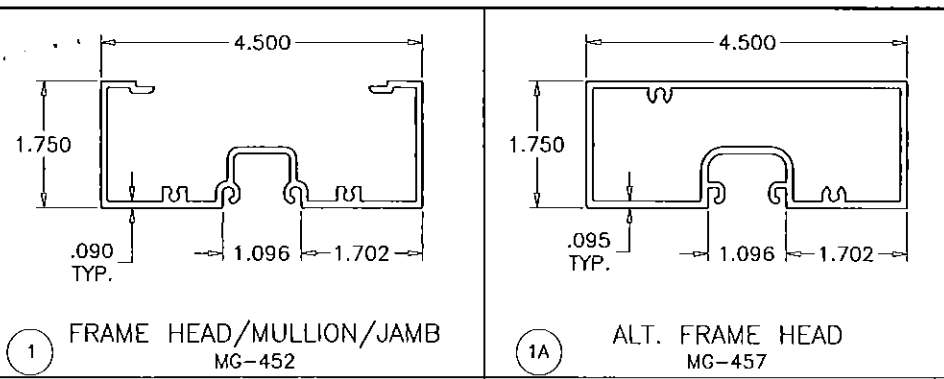

1 FRAME HEAD/MULLION/JAMB  
MG-452

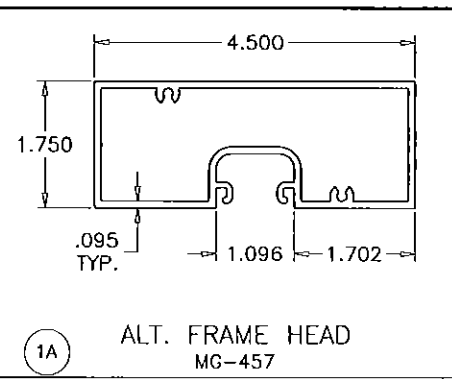

1A ALT. FRAME HEAD  
MG-457

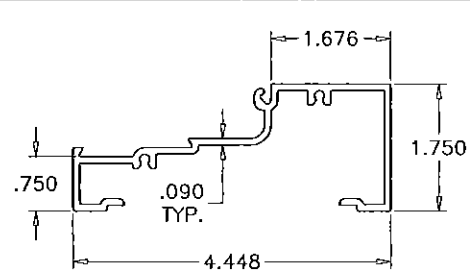

2 FRAME SILL/HORIZONTAL  
MG-453

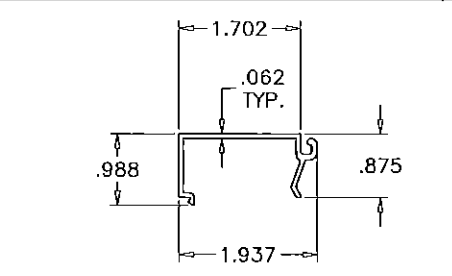

4 GLAZING STOP  
MG-454

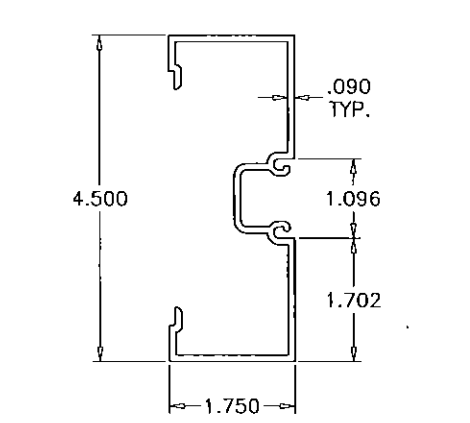

5 FRAME JAMB

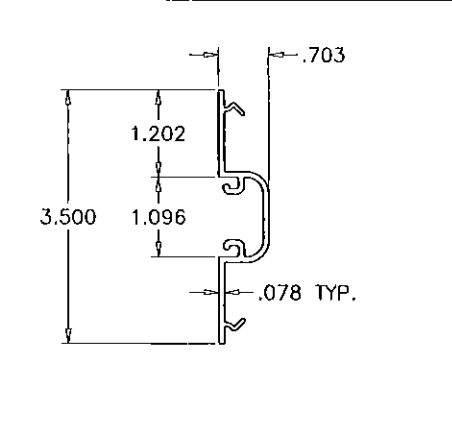

6 POCKET FILLER  
MG-458

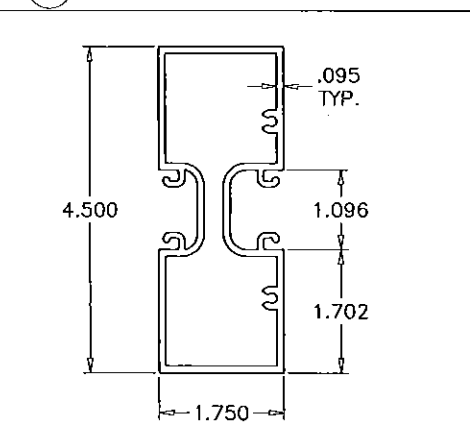

8 FRAME MULLION  
MG-456

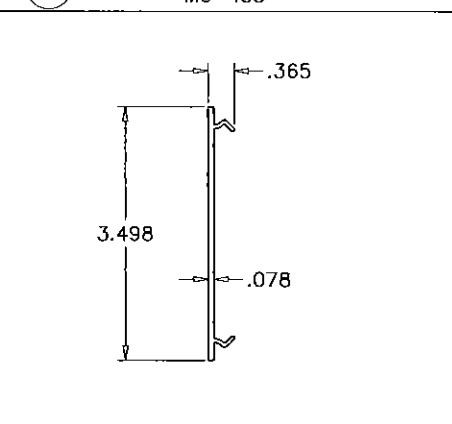

7 SNAP IN COVER  
MG-459

ITEM NO.	PART NUMBER	QUANTITY	DESCRIPTION	MATERIAL	MANF./SUPPLIER/REMARKS
1	MG-452	-	FRAME HEAD/MULLION/JAMB	6063-T6	-
1A	MG-457	-	ALT. FRAME HEAD	6063-T6	-
2	MG-453	-	FRAME SILL/HORIZONTAL	6063-T6	-
4	MG-454	-	GLAZING STOP	6063-T6	-
5	-	-	FRAME JAMB	6063-T6	-
6	MG-458	-	POCKET FILLER	6063-T6	-
7	MG-459	-	SNAP IN COVER	6063-T6	-
8	MG-456	-	FRAME MULLION	6063-T6	-
9	2028	AS REQD.	GLAZING GASKET	NEOPRENE	CAROLINA CUSTOM RUBBER, DUROMETER 70±5
10	SB563	2/ LITE	SETTING BLOCK, 1/4" X 1/2" X 2" LONG, AT 3" FROM EACH END	NEOPRENE	C.R. LAURENCE, DUROMETER 80±5
11	#8 X 1"	2/ CORNER	ASSEMBLY SCREWS (PH SELF DRILLING)	-	GRADE 4 CRS, Fu=92 KSI, Fy=120 KSI
12	-	-	REINFORCING CHANNEL	STEEL	ASTM A36, Fy 36 KSI

**SEALANTS:**

ALL FRAME CORNERS, JOINTS, MULLION SEAMS AND PERIMETER OF GLAZING BEAD TO FRAME TO BE SEALED WITH DOW CORNING 795 SEALANT.

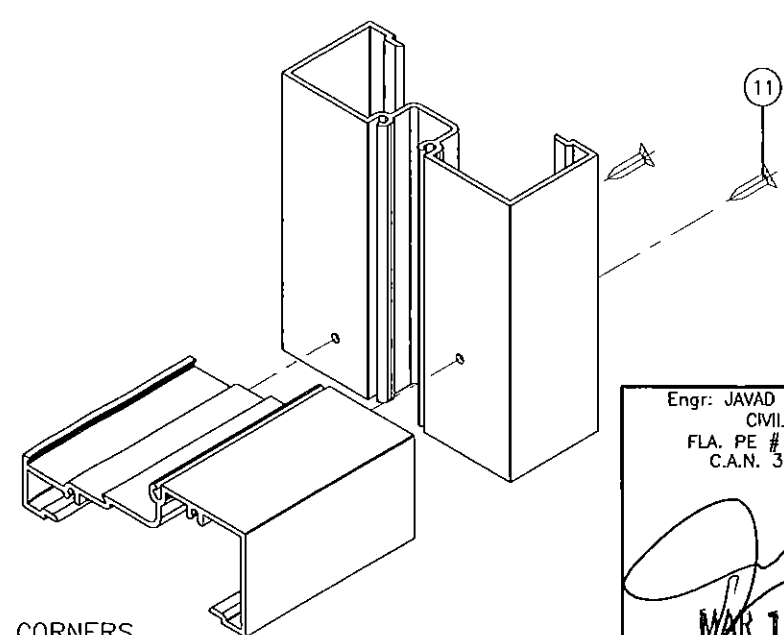
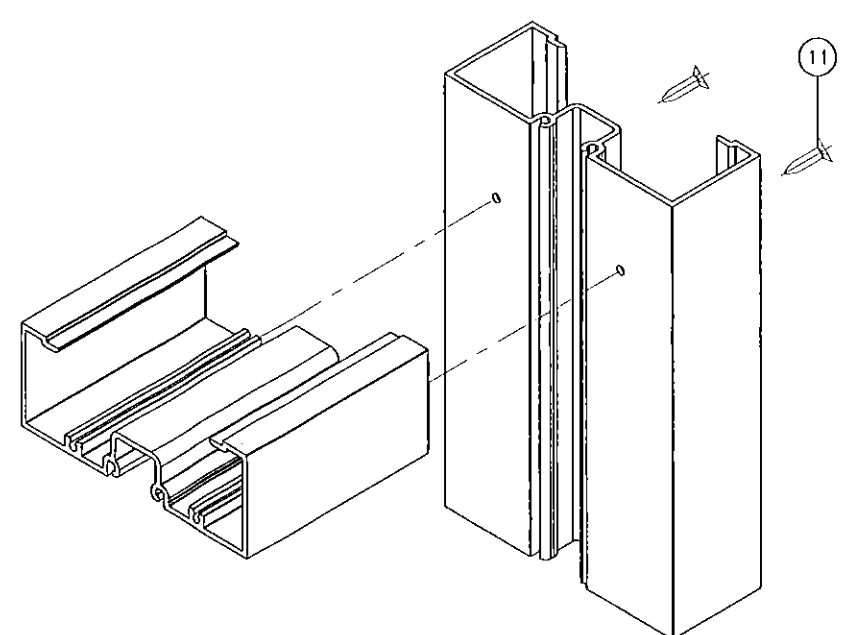

FRAME CORNERS

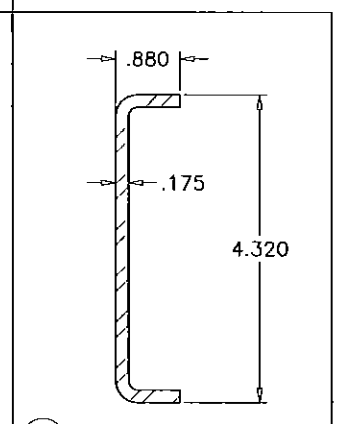

12 STEEL REINFORCING

Engr: JAVAD AHMAD  
CIVIL  
FLA. PE # 70592  
C.A.N. 3538  
MAR 11 2015

PRODUCT REVISED  
as complying with the Florida  
Building Code  
Acceptance No 15-0401.01  
Expiration Date OCT 6, 2016  
By *Hamid Perez*  
Miami Dade Product Control

**af c**  
**AL-FAROOQ CORPORATION**  
ENGINEERS & PRODUCT DEVELOPMENT  
1235 S.W. 87 AVE  
MIAMI, FLORIDA 33174  
TEL. (305) 264-8100 FAX. (305) 262-6978  
COMP - ANL \ W10-75MRG

MG-4500 ALUMINUM FLUSH GLAZED SYSTEM (N.I.)  
**MR. GLASS DOORS & WINDOWS INC.**  
7440 N.W. 66 STREET  
MIAMI, FL. 33166  
TEL. (305) 470-8284 FAX. (305) 470-8285

revisions:	no	date	by	description
	A	09.14.11		REV. PER BNC COMMENTS
	B	03.04.15		NO CHANGE THIS SHEET

date: 10-15-10  
scale: 3/8" = 1"  
dr. by: HAMID  
chk. by:

drawing no. **W10-75**  
sheet 9 of 9