



DEPARTMENT OF REGULATORY AND ECONOMIC RESOURCES (RER)  
BOARD AND CODE ADMINISTRATION DIVISION

MIAMI-DADE COUNTY  
PRODUCT CONTROL SECTION  
11805 SW 26 Street, Room 208  
Miami, Florida 33175-2474  
T (786) 315-2590 F (786) 315-2599  
[www.miamidade.gov/economy](http://www.miamidade.gov/economy)

## NOTICE OF ACCEPTANCE (NOA)

**Air Vent, Inc.**  
4117 Pinnacle Point Drive, Suite 400  
Dallas, TX. 75211-1350

### SCOPE:

This NOA is being issued under the applicable rules and regulations governing the use of construction materials. The documentation submitted has been reviewed and accepted by Miami-Dade County RER - Product Control Section to be used in Miami-Dade County and other areas where allowed by the Authority Having Jurisdiction (AHJ).

This NOA shall not be valid after the expiration date stated below. The Miami-Dade County Product Control Section (in Miami-Dade County) and/or the AHJ (in areas other than Miami-Dade County) reserve the right to have this product or material tested for quality assurance purposes. If this product or material fails to perform in the accepted manner, the manufacturer will incur the expense of such testing and the AHJ may immediately revoke, modify, or suspend the use of such product or material within their jurisdiction. RER reserves the right to revoke this acceptance, if it is determined by Miami-Dade County Product Control Section that this product or material fails to meet the requirements of the applicable building code.

This product is approved as described herein, and has been designed to comply with the Florida Building Code including the High Velocity Hurricane Zone of the Florida Building Code.

### DESCRIPTION: Hip Ridge Vent™

**LABELING:** Each unit shall bear a permanent label with the manufacturer's name or logo, city, state and following statement: "Miami-Dade County Product Control Approved", unless otherwise noted herein.

**RENEWAL** of this NOA shall be considered after a renewal application has been filed and there has been no change in the applicable building code negatively affecting the performance of this product.

**TERMINATION** of this NOA will occur after the expiration date or if there has been a revision or change in the materials, use, and/or manufacture of the product or process. Misuse of this NOA as an endorsement of any product, for sales, advertising or any other purposes shall automatically terminate this NOA. Failure to comply with any section of this NOA shall be cause for termination and removal of NOA.

**ADVERTISEMENT:** The NOA number preceded by the words Miami-Dade County, Florida, and followed by the expiration date may be displayed in advertising literature. If any portion of the NOA is displayed, then it shall be done in its entirety.

**INSPECTION:** A copy of this entire NOA shall be provided to the user by the manufacturer or its distributors and shall be available for inspection at the job site at the request of the Building Official.

This NOA renews NOA No. 11-0822.07 and consists of pages 1 through 4.  
The submitted documentation was reviewed by Alex Tigera.



NOA No. 16-0906.02  
Expiration Date: 12/15/21  
Approval Date: 11/10/16  
Page 1 of 4

## ROOFING COMPONENT APPROVAL

**Category:** Roofing  
**Sub-Category:** Ventilation  
**Materials:** Plastic

### TRADE NAMES OF PRODUCTS MANUFACTURED OR LABELED BY APPLICANT:

<u>Product</u>	<u>Dimensions</u>	<u>Test Specification</u>	<u>Product Description</u>
Hip Ridge Vent™	H= 7/8" W=13-15/16" L=48"	TAS 100	Plastic low profile shingle over attic vent, for use on hips of shingle roof systems.

### MANUFACTURING LOCATION(S):

1. Orrick, MO.

### EVIDENCE SUBMITTED:

<u>Test Agency/Identifier</u>	<u>Name</u>	<u>Report</u>	<u>Date</u>
Hurricane Engineering and Testing	ASTM D 638	HETI-09-T151	01/08/10
		HETI-09-T152	10/08/10
	ASTM D 1929	HETI-09-F407	01/08/10
	ASTM G-155	HETI-02-A001	09/13/02
Architectural Testing, Inc.	TAS 100A(95)	A3223.01-801-44	04/25/11
	Wind Driven Rain – Modified per Proposal		



NOA No. 16-0906.02  
Expiration Date: 12/15/21  
Approval Date: 11/10/16  
Page 2 of 4

## APPROVED APPLICATIONS

**Tradename:** Hip Ridge Vent™

**System Type:** Mechanical attachment of static vent over asphalt shingle roof systems only.

**Minimum Slope:** 3:12

**Maximum Slope:** 12:12

**Cutout:** Cut a minimum 6" slot along the apex of the roof hip by cutting 3" on each side of the hip. The slot shall terminate approximately 6" from the top and 12" from the bottom of the hip.

**Installation:** Place Hip Ridge Vent™ centered over the void at one end of the hip ridge. There should be 6-1/2" of the vent on either side of the hip/ridge. Secure the vent with 2-1/2" galvanized ring shank nails through pre-formed nail bosses along the vent.

**Ridge Shingle:** Nail cap shingles in place using roofing nails long enough to penetrate through the roof sheathing a minimum of 3/16 of an inch.

**Net Free Area:** Refer to manufacturers published literature.

## LIMITATIONS:

1. Refer to applicable Building Codes for required ventilation.
2. This acceptance is for installations over asphalt shingle roof systems only.
3. Hip Ridge Vent™ shall not be installed on roof mean heights greater than 33 feet.
4. All products listed herein shall have a quality assurance audit in accordance with the Florida Building Code and Rule 61G20-3 of the Florida Administrative Code.
5. All approved products listed herein shall be labeled and shall bear the imprint or identifiable marking of the manufacturer's name or logo and following statement: "Miami-Dade County Product Control Approved" or the Miami-Dade County Product Control Seal as shown below.



NOA No. 16-0906.02  
Expiration Date: 12/15/21  
Approval Date: 11/10/16  
Page 3 of 4

# DETAIL DRAWINGS

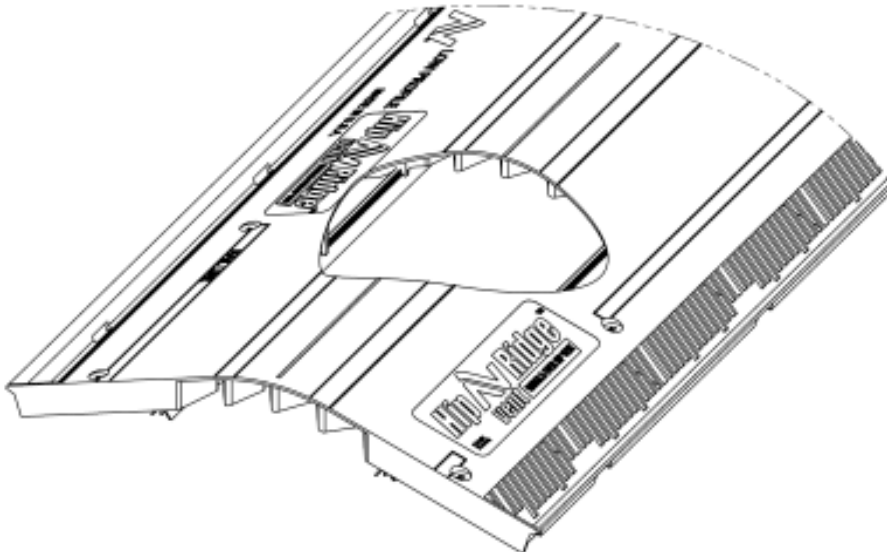
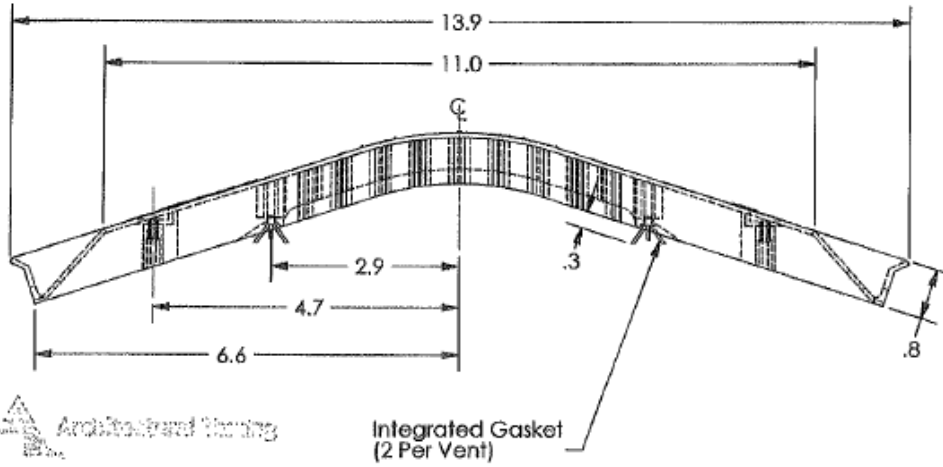
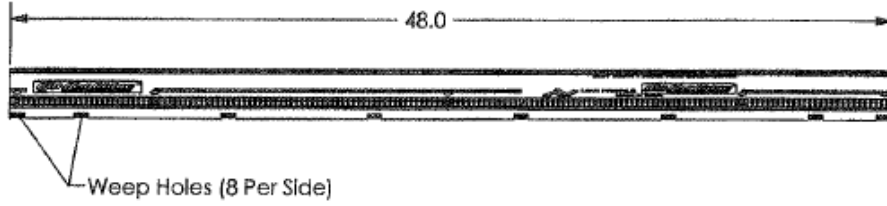

**END OF THIS ACCEPTANCE**



NOA No. 16-0906.02  
Expiration Date: 12/15/21  
Approval Date: 11/10/16  
Page 4 of 4