



DEPARTMENT OF REGULATORY AND ECONOMIC RESOURCES (RER)  
BOARD AND CODE ADMINISTRATION DIVISION

MIAMI-DADE COUNTY  
PRODUCT CONTROL SECTION  
11805 SW 26 Street, Room 208  
Miami, Florida 33175-2474  
T (786) 315-2590 F (786) 315-2599  
[www.miamidade.gov/economy](http://www.miamidade.gov/economy)

## NOTICE OF ACCEPTANCE (NOA)

**Metal-Era Inc.**  
**1600 Airport Road**  
**Waukesha, WI. 53188**

### SCOPE:

This NOA is being issued under the applicable rules and regulations governing the use of construction materials. The documentation submitted has been reviewed and accepted by Miami-Dade County RER - Product Control Section to be used in Miami Dade County and other areas where allowed by the Authority Having Jurisdiction (AHJ).

This NOA shall not be valid after the expiration date stated below. The Miami-Dade County Product Control Section (In Miami Dade County) and/or the AHJ (in areas other than Miami Dade County) reserve the right to have this product or material tested for quality assurance purposes. If this product or material fails to perform in the accepted manner, the manufacturer will incur the expense of such testing and the AHJ may immediately revoke, modify, or suspend the use of such product or material within their jurisdiction. RER reserves the right to revoke this acceptance, if it is determined by Miami-Dade County Product Control Section that this product or material fails to meet the requirements of the applicable building code.

This product is approved as described herein, and has been designed to comply with the Florida Building Code including the High Velocity Hurricane Zone of the Florida Building Code.

### DESCRIPTION: Hi-Perf Ridge Vent, Slope to Slope

**LABELING:** Each unit shall bear a permanent label with the manufacturer's name or logo, city, state and following statement: "Miami-Dade County Product Control Approved", unless otherwise noted herein.

**RENEWAL** of this NOA shall be considered after a renewal application has been filed and there has been no change in the applicable building code negatively affecting the performance of this product.

**TERMINATION** of this NOA will occur after the expiration date or if there has been a revision or change in the materials, use, and/or manufacture of the product or process. Misuse of this NOA as an endorsement of any product, for sales, advertising or any other purposes shall automatically terminate this NOA. Failure to comply with any section of this NOA shall be cause for termination and removal of NOA.

**ADVERTISEMENT:** The NOA number preceded by the words Miami-Dade County, Florida, and followed by the expiration date may be displayed in advertising literature. If any portion of the NOA is displayed, then it shall be done in its entirety.

**INSPECTION:** A copy of this entire NOA shall be provided to the user by the manufacturer or its distributors and shall be available for inspection at the job site at the request of the Building Official.

This NOA renews NOA# 23-0517.02 and consists of pages 1 through 6.  
The submitted documentation was reviewed by Alex Tigera.

07/11/24



NOA No.: 24-0424.02  
Expiration Date: 07/11/29  
Approval Date: 06/27/24  
Page 1 of 6

# ROOFING COMPONENT APPROVAL

**Category:** Roofing  
**Sub-Category:** Ventilation  
**Material:** See component herein  
**Minimum Slope:** 2:12

## TRADE NAMES OF PRODUCTS MANUFACTURED OR LABELED BY APPLICANT

<u>Product</u>	<u>Dimensions</u>	<u>Test Specification</u>	<u>Product Description</u>
Hi-Perf Ridge Vent, Slope to Slope	See drawings herein and component descriptions below.	TAS 100(A)	Static ridge vent shingle comprised of an expanded metal screen, Z-brackets, intermittent spacer brackets, cover plate, splice plates, and end caps. Designed to be used with deflectors on each side of the slope.

### Hi-Perf Ridge Vent consists of the following components:

**Z-Brackets** Height:  $\frac{5}{8}$ " -  $3\text{-}\frac{3}{8}$ "  
 Width: 2" -  $4\text{-}\frac{1}{2}$ "  
 Length: continuous  
 Thickness:  
 Steel 20 ga.

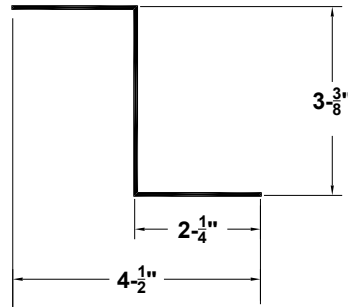

Maximum dimensions shown in drawing

**Metal Screen** Height: N/A  
 Width: varies depending on angle of roof slope.  
 Length: continuous  
 Thickness:  
 Aluminum 0.050"

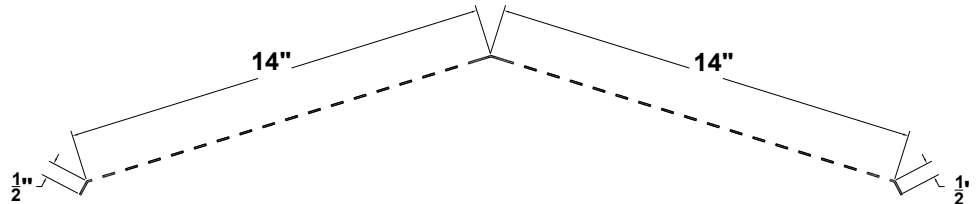

**Intermittent Spacer Brackets** Height:  $\frac{1}{8}$ " -  $2\text{-}\frac{7}{8}$ "  
 Width: 2"  
 Length: max 28"  
 Thickness:  
 Aluminum 0.050", 0.063"

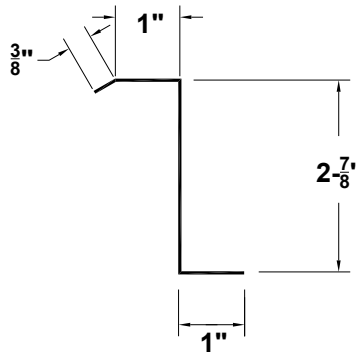

**Ridgevent Cover** Height: N/A  
 Width: varies depending on angle of roof slope.  
 Length: 12'  
 Thickness:  
 Steel: 24 ga.  
 Aluminum: 0.040", 0.050", 0.063"

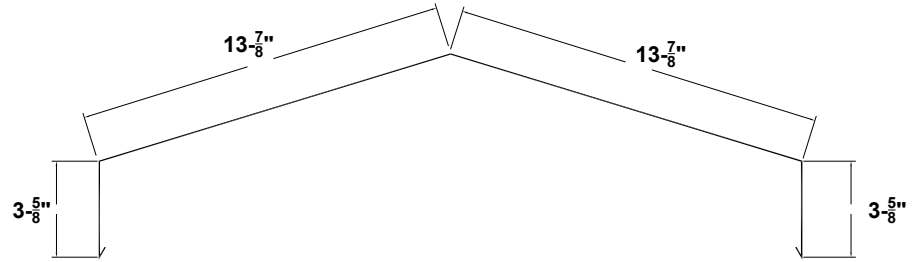

**Splice Plate** Height: N/A  
 Width: varies depending on angle of roof slope.  
 Length: continuous  
 Thickness:  
 Steel: 24 ga.  
 Aluminum: 0.040", 0.050", 0.063"

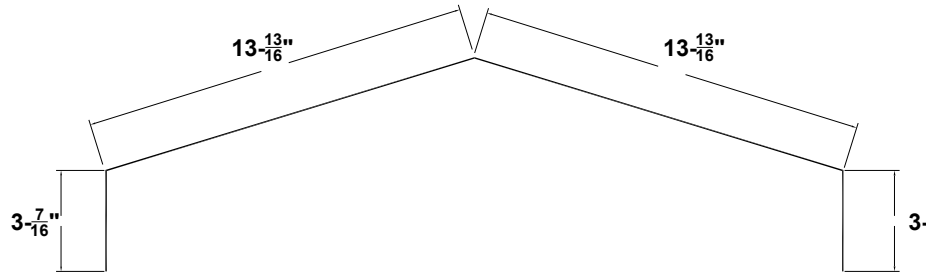

**End Cap** Height: N/A  
 Width: varies depending on angle of roof slope.  
 Length: continuous  
 Thickness:  
 Steel: 24 ga.  
 Aluminum: 0.040", 0.050", 0.063"

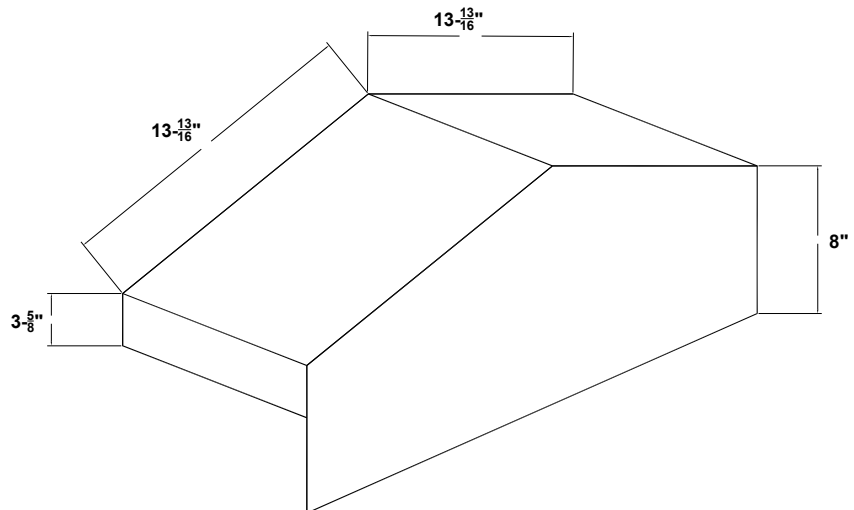

**Deflector** 6" x 6" typ.  
 Proportional with size of vent.  
 Length: continuous  
 Thickness:  
 Steel: 24 ga.  
 Aluminum: 0.040", 0.050", 0.063"

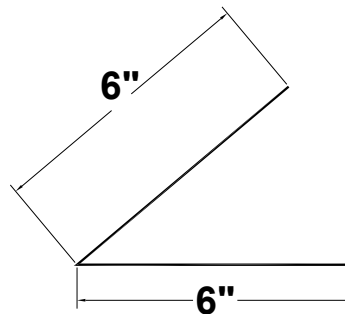

Maximum dimensions shown in drawing



## MANUFACTURING LOCATION

1. Waukesha, WI.

## EVIDENCE SUBMITTED

<u>Test Agency/Identifier</u>	<u>Name</u>	<u>Report</u>	<u>Date</u>
PRI Construction Materials Technologies LLC.	2711T0001	TAS-100(A)	06/27/24
Valspar		ASTM G23	05/10/06
		ASTM B 117	05/10/06



## APPROVED APPLICATIONS:

**Trade Name:** Hi-Perf Ridge Vent, Slope to Slope

**System Type A:** Mechanical attachment of static ridge vent over asphalt shingles.

- Installation:**
1. Allow a 6" opening centered in the deck at the ridge for ventilation. Approximately 3" on each side of the ridge. The slot shall terminate approximately 6" from the rake edges.
  2. Install the Z-Brackets placing a 3/8" bead of sealant along the bottom of the Z-Bracket. Place the Z-Bracket at the edge of the cutout and secure it to the prepared roof with #10 x 1", phillips head, sharp point wood screws with 7/16" head diameter spaced 6" o.c.
  3. Place the Metal Screen over the Z-Brackets and temporarily secure to the Metal Screen to the Z-Brackets using #8-18 x 3/4" pan head self drilling screws.
  4. Intermittent Spacer Brackets are installed over the Metal Screen with two #8-18 x 3/4" pan head self drilling screws through the Metal Screen and into the Z-Bracket.
  5. Install a Splice Plate into one End Cap and seal with two beads of sealant, 3/8" in diameter, and rivet with one 1/8" diameter rivet on each side. The End Cap with Splice Plate is mounted onto the Metal Screen on one end and fastened to the roof deck with two #10x1" long, Phillips head, sharp point wood screws with a 7/16" head diameter.
  6. Prepare Ridgevent Cover by mounting a Splice Plate with two beads of sealant, 3/8" in diameter, and rivet with one 1/8" diameter rivet on each side. The opposite end of the Ridgevent Cover is slid over the existing Metal Screen and Intermittent Spacer Brackets starting at the end opposite of the previously installed End Cap. Two beads of sealant, 3/8" in diameter, are placed on the existing Splice Plate installed with the previous End Cap and the blank end of the Ridgevent Cover is slid over the exposed Splice Plate leaving a 3/8" gap between the Ridgevent Cover and the End Plate. The Ridgevent Cover is riveted on each side with a 1/8" diameter rivet.
  7. Install the End Cap on the opposite end by overlapping the Splice Plate and two beads of sealant, 3/8" in diameter. Leave a 3/8" gap between the Ridgevent Cover and the End Plate.
  8. Mount the Wind Deflector, on each side of the vent, 3" down the slope from the installed ridge vent. Place two beads of sealant, 3/8" in diameter, along the bottom of the deflector. And secure to the prepared roof deck with #10-13 x 1-1/2" hex drive pan head screws with #10 rubber backed washers 0.60" in diameter. Fasteners are spaced 12" o.c.

**Net Free Area:** Refer to Manufacturer's Published Literature

**Minimum Slope:** 2:12



NOA No.: 24-0424.02  
Expiration Date: 07/11/29  
Approval Date: 06/27/24  
Page 5 of 6

## LIMITATIONS:

1. Refer to applicable Building Code required ventilation.
2. Hi-Perf Ridge Vent, Slope to Slope shall comply with applicable Building Code.
3. Hi-Perf Ridge Vent, Slope to Slope shall not be installed on roof mean heights greater than 33 feet.
4. All products listed herein shall have a quality assurance audit in accordance with the Florida Building Code and Rule 61G20-3 of the Florida Administrative Code.

## DETAIL A

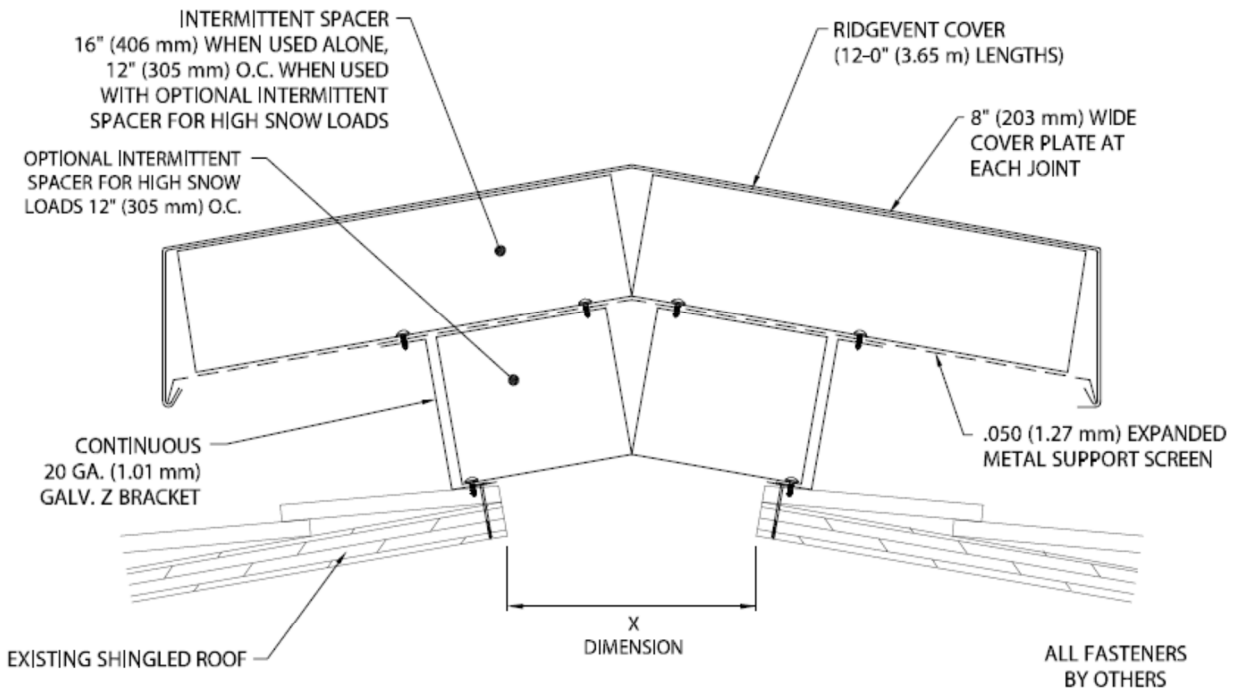

*CAUTION! INSTALLERS SHALL WEAR PROTECTIVE EYE WEAR TO PREVENT INJURY. DO NOT OVERDRIVE FASTENERS, AS STRIPPING CAN OCCUR AT HIGH DRIVER TORQUE. RECOMMENDED DRIVING TOOL: 600 - 800 rpm ELECTRIC DRILL EQUIPPED WITH DEPTH-SENSING NOSE-PIECE TO PREVENT DRIVING AND STRIPOUT. DO NOT USE IMPACT TYPE TOOL.*

*IMPORTANT! BE SURE TO REMOVE PROTECTIVE PLASTIC FILM PRIOR TO INSTALLING EACH COVER SECTION.*

NOTE: ALL FASTENERS MUST MEET MINIMUM 240 LB. PULL-OUT FOR SUBSTRATE.

## END OF THIS ACCEPTANCE