



MIAMI-DADE COUNTY, FLORIDA
PRODUCT CONTROL SECTION
 11805 SW 26 Street, Room 208
 Miami, Florida 33175-2474
 T (786) 315-2590 F (786) 315-2599
www.miamidade.gov/building

**DEPARTMENT OF REGULATORY AND ECONOMIC RESOURCES (RER)
 BOARD AND CODE ADMINISTRATION DIVISION
 NOTICE OF ACCEPTANCE (NOA)**

PGT Industries, Inc.
3400 Precision Drive,
North Venice, Fl. 34275

SCOPE:

This NOA is being issued under the applicable rules and regulations governing the use of construction materials. The documentation submitted has been reviewed and accepted by Miami-Dade County RER-Product Control Section to be used in Miami-Dade County and other areas where allowed by the Authority Having Jurisdiction (AHJ).

This NOA shall not be valid after the expiration date stated below. The Miami-Dade County Product Control Section (In Miami-Dade County) and/or the AHJ (in areas other than Miami-Dade County) reserve the right to have this product or material tested for quality assurance purposes. If this product or material fails to perform in the accepted manner, the manufacturer will incur the expense of such testing and the AHJ may immediately revoke, modify, or suspend the use of such product or material within their jurisdiction. RER reserves the right to revoke this acceptance, if it is determined by Miami-Dade County Product Control Section that this product or material fails to meet the requirements of the applicable building code.

This product is approved as described herein, and has been designed to comply with the Florida Building Code, including the High Velocity Hurricane Zone.

DESCRIPTION: Series “SGD-770HP” Aluminum Sliding Glass Door w/ Reinforcements – S.M.I.

APPROVAL DOCUMENT: Drawing No. **PGT0005 Rev J**, titled “Aluminum Sliding Glass Door (SM)”, sheets 1 through 10 of 10, dated 03/21/20 and last revised on 12/20/2024, prepared by manufacturer, signed and sealed by Anthony Lynn Miller, P.E., bearing the Miami-Dade County Product Control Renewal stamp with the Notice of Acceptance number and expiration date by the Miami-Dade County Product Control Section.

MISSILE IMPACT RATING: Small Missile Impact Resistant

LIMITATIONS:

1. See Tables **1 & 1A** in sheet **4** of this approved drawing set for applicable SGD unit sizes, design pressures, reinforcements, glass types, sill riser and anchors requirements. See approved configurations in sheet **2**.
2. Applicable operable door egress min. clear width & height requirements must comply per FBC, to be reviewed by Building Official.
3. See glazing options **G9, G9A, G10** and **G10A** in sheets **1 & 3**.

LABELING: Each unit shall bear a permanent label with the manufacturer's name or logo, city, state and series and following statement: "Miami-Dade County Product Control Approved", unless otherwise noted herein.

RENEWAL of this NOA shall be considered after a renewal application has been filed and there has been no change in the applicable building code negatively affecting the performance of this product.



NOA No. 25-0102.02
Expiration Date: March 24, 2030
Approval Date: January 16, 2025
 Page 1



MIAMI-DADE COUNTY, FLORIDA
PRODUCT CONTROL SECTION
 11805 SW 26 Street, Room 208
 Miami, Florida 33175-2474
 T (786) 315-2590 F (786) 315-2599
www.miamidade.gov/building

DEPARTMENT OF REGULATORY AND ECONOMIC RESOURCES (RER)
 BOARD AND CODE ADMINISTRATION DIVISION
NOTICE OF ACCEPTANCE (NOA)

PGT Industries, Inc.
 3400 Precision Drive,
 North Venice, Fl. 34275

TERMINATION of this NOA will occur after the expiration date or if there has been a revision or change in the materials, use, and/ or manufacture of the product or process. Misuse of this NOA as an endorsement of any product, for sales, advertising or any other purposes shall automatically terminate this NOA. Failure to comply with any section of this NOA shall be cause for termination and removal of NOA.

ADVERTISEMENT: The NOA number preceded by the words Miami-Dade County, Florida, and followed by the expiration date may be displayed in advertising literature. If any portion of the NOA is displayed, then it shall be done in its entirety.

INSPECTION: A copy of this entire NOA shall be provided to the user by the manufacturer or its distributors and shall be available for inspection at the job site at the request of the Building Official. This NOA **revises & renews NOA No. 23-0710.06 (PGT Industries, Inc.)** and consists of these pages 1 and 2, and evidence pages E-1, E-2, E-3, E-4 and E-5, as well as approval document mentioned above.

The submitted documentation was reviewed by **Ishaq I. Chanda, P.E.** *Ishaq I. Chanda*



NOA No. 25-0102.02
 Expiration Date: March 24, 2030
 Approval Date: January 16, 2025
 Page 2

NOTICE OF ACCEPTANCE: EVIDENCE SUBMITTED

1. EVIDENCE SUBMITTED UNDER PREVIOUS NOA's

A. DRAWINGS

1. Manufacturer's die drawings and sections.
(Submitted under NOA's No. 09-0826.11 and No. 11-1018.15)
2. Drawing No. **PGT0005**, titled "Aluminum Sliding Glass Door (SM)", sheets 1 through 10 of 10 dated 08/05/07, with revision **H** dated 03/21/20, prepared by manufacturer, signed and sealed by Anthony Lynn Miller, P.E.
(Submitted under NOA No. 20-0429.11)

B. TESTS

1. Test reports on: 1) Air Infiltration Test, per FBC, TAS 202-94
2) Uniform Static Air Pressure Test, Loading per FBC, TAS 202-94
3) Water Resistance Test, per FBC, TAS 202-94
4) Large Missile Impact Test per FBC, TAS 201-94
5) Cyclic Wind Pressure Loading per FBC, TAS 203-94
along with marked-up drawings and installation diagram of all PGT Industries, Inc. representative units listed below and tested to qualify **Dowsil 791** and **Dowsil 983** silicones, prepared by Fenestration Testing Laboratory, Inc., Test Reports No.: **FTL-7897**, PGT PW5520 PVC Fixed Window (unit 6 in proposal), dated 09/03/14
FTL-20-2107.1, PGT SGD780 Aluminum Sliding Glass Door (unit 7 in proposal)
FTL-20-2107.2, PGT CA740 Alum. Outswing Casement Window (unit 8 in proposal)
FTL-20-2107.3, PGT PW7620A Aluminum Fixed Window (unit 9 in proposal) and
FTL-20-2107.4, PGT PW7620A Aluminum Fixed Window (unit 10 in proposal) dated 07/13/20, all signed and sealed by Idalmis Ortega, P.E.
(Submitted under NOA No. 20-0429.11)
2. Test reports on: 1) Uniform Static Air Pressure Test, Loading per FBC TAS 202-94
2) Large Missile Impact Test per FBC, TAS 201-94
3) Cyclic Wind Pressure Loading per FBC, TAS 203-94
along with marked-up drawings and installation diagram of a PVC sliding glass door, a PVC fixed window and an aluminum sliding glass door, using: Kodispace 4SG TPS spacer system, Duraseal[®] spacer system, Super Spacer[®] NXT[™] spacer system and XL Edge[™] spacer system at insulated glass, prepared by Fenestration Testing Laboratory, Inc., Test Reports No. **FTL-8717**, **FTL-8970** and **FTL-8968**, dated 02/15/16, 06/07/16 and 06/20/16 respectively, all signed and sealed by Idalmis Ortega, P.E.
(Submitted under NOA No. 16-0629.08)

Ishaq I. Chanda

Ishaq I. Chanda, P.E.
Product Control Unit Supervisor
NOA No. 25-0102.02
Expiration Date: March 24, 2030
Approval Date: January 16, 2025

NOTICE OF ACCEPTANCE: EVIDENCE SUBMITTED

1. EVIDENCE SUBMITTED UNDER PREVIOUS NOA's (CONTINUED)
B. TESTS (CONTINUED)

3. Test reports on: 1) Air Infiltration Test, per FBC, TAS 202-94
2) Uniform Static Air Pressure Test, Loading per FBC TAS 202-94
3) Water Resistance Test, per FBC, TAS 202-94
4) Large Missile Impact Test per FBC, TAS 201-94
5) Cyclic Wind Pressure Loading per FBC, TAS 203-94
6) Forced Entry Test, per FBC 2411 3.2.1 and TAS 202-94
along with marked-up drawings and installation diagram of aluminum sliding glass door (XOX), prepared by Fenestration Testing Laboratory, Inc., Test Report No. **FTL-7825**, dated 06/10/14, signed and sealed by Idalmis Ortega, P.E.
(Submitted under NOA No. 15-0106.09)
4. Test reports on: 1) Air Infiltration Test, per FBC, TAS 202-94
2) Uniform Static Air Pressure Test, Loading per FBC TAS 202-94
3) Water Resistance Test, per FBC, TAS 202-94
4) Small Missile Impact Test per FBC, TAS 201-94
5) Cyclic Wind Pressure Loading per FBC, TAS 203-94
6) Forced Entry Test, per FBC 2411 3.2.1 and TAS 202-94
along with marked-up drawings and installation diagram of aluminum sliding glass door (Samples A-3, A-4, B-3, B-4 and C-2), prepared by Fenestration Testing Laboratory, Inc., Test Report No. **FTL-7468**, dated 09/13/13, signed and sealed by Marlin D. Brinson, P.E.
(Submitted under NOA No. 09-0826.11)
5. Test reports on: 1) Air Infiltration Test, per FBC, TAS 202-94
2) Uniform Static Air Pressure Test, Loading per FBC, TAS 202-94
3) Water Resistance Test, per FBC, TAS 202-94
4) Forced Entry Test, Per FBC 2411.3.2.1 (b) TAS 202-94
5) Small Missile Impact Test per FBC, TAS 201-94
6) Cyclic Wind Pressure Loading per FBC, TAS 203-94
along with marked-up drawings and installation diagram of aluminum sliding glass door, prepared by Fenestration Testing Laboratory, Inc., Test Reports No. **FTL-6019** and **FTL-6020**, both dated 08/10/09 and signed and sealed by Julio Gonzalez, P.E.
Note: Test Report No. **FTL-6019** has been revised and re-issued on 12/29/09, signed and sealed by Julio Gonzalez, P.E.
(Submitted under NOA No. 09-0826.11)
6. Additional reference supporting Test Reports No. **FTL-5254** and No. **ATI-72138.01-401-18**.

Ishaq I. Chanda

Ishaq I. Chanda, P.E.
Product Control Unit Supervisor
NOA No. 25-0102.02
Expiration Date: March 24, 2030
Approval Date: January 16, 2025

NOTICE OF ACCEPTANCE: EVIDENCE SUBMITTED

1. EVIDENCE SUBMITTED UNDER PREVIOUS NOA's (CONTINUED)

C. CALCULATIONS

1. Anchor verification calculations and structural analysis, complying with **FBC 7th Edition (2020)**, dated 04/20/20, prepared by manufacturer, signed and sealed by Anthony Lynn Miller, P.E.
(Submitted under NOA No. 20-0429.09)
2. Glazing complies with **ASTM E 1300-04, -09, -12**.

D. QUALITY ASSURANCE

1. Miami-Dade Department of Regulatory and Economic Resources (RER)

E. MATERIAL CERTIFICATIONS

1. Notice of Acceptance No. **19-0305.02** issued to **Kuraray America, Inc.** for their "**Trosifol® Ultraclear, Clear and Color PVB Glass Interlayers**" dated 05/09/19, expiring on 07/08/24.

F. STATEMENTS

1. Statement letter of conformance, complying with **FBC 7th Edition (2020)** dated April 20, 2020, issued by manufacturer, signed and sealed by Anthony Lynn Miller, P.E.
(Submitted under NOA No. 20-0429.11)
2. Statement letter of no financial interest dated April 20, 2020, issued by manufacturer, signed and sealed by Anthony Lynn Miller, P.E.
(Submitted under NOA No. 20-0429.11)
3. Proposal No. **16-0152** dated 03/09/16, approved by Product Control.
(Submitted under NOA No. 16-0629.06)
4. Department of State Certification of **PGT INDUSTRIES, INC.** as a for profit corporation, active and organized under the laws of the State of Florida, dated 01/27/15 and filed by the Secretary of State.
(Submitted under NOA No. 16-0629.06)
5. Notification of Successor Engineer for manufacturer's NOA document per **Section 61G15-27.001** of the **Florida Administrative Code**, notifying original engineer that the successor engineer is assuming full professional and legal responsibility for all engineering documents pertaining to this NOA, dated 10/07/11, signed and sealed by Lynn A. Miller, P.E.
(Submitted under NOA No. 11-1018.15)
6. Letter of lab compliance, part of the above test reports.
(Submitted under NOA No. 09-0826.11) *Ishaq I. Chanda*

Ishaq I. Chanda, P.E.
Product Control Unit Supervisor
NOA No. 25-0102.02
Expiration Date: March 24, 2030
Approval Date: January 16, 2025

PGT Industries, LLC

NOTICE OF ACCEPTANCE: EVIDENCE SUBMITTED

1. EVIDENCE SUBMITTED UNDER PREVIOUS NOA's (CONTINUED)

G. OTHERS

1. Notice of Acceptance No. **19-1126.05**, issued to PGT Industries, Inc., for their **Series "770HP" Aluminum Sliding Glass Doors w/ Reinforcements – S.M.I.**, approved on 01/09/20 and expiring on 03/24/25.

2. EVIDENCE SUBMITTED under previous approval

A. DRAWINGS

1. Drawing No. **PGT0005**, titled "Aluminum Sliding Glass Door (SM)", sheets 1 through 10 of 10, dated 03/21/20, with revision **I** dated 06/06/23, prepared by manufacturer, signed and sealed by Anthony Lynn Miller, P.E.

B. TESTS

1. None.

C. CALCULATIONS

1. None

D. QUALITY ASSURANCE

1. Miami-Dade Department of Regulatory and Economic Resources (RER)

E. MATERIAL CERTIFICATIONS

1. Notice of Acceptance No. **20-0915.22** issued to **Kuraray America, Inc.** for their "**Trosifol® Ultraclear, Clear and Color PVB Glass Interlayers**" dated 11/19/20, expiring on 07/08/24.

F. STATEMENTS

1. Statement letter of conformance, complying with **FBC 7th Edition (2020)**, and with **FBC 8th Edition (2023)** dated June 06, 2023, issued by manufacturer, signed and sealed by Anthony Lynn Miller, P.E.
2. Statement letter of no financial interest dated June 06, 2023, issued by manufacturer, signed and sealed by Anthony Lynn Miller, P.E.

G. OTHERS

1. Notice of Acceptance No. **20-0429.11**, issued to PGT Industries, Inc., for their **Series "770HP" Aluminum Sliding Glass Doors w Reinforcements – S.M.I.**, approved on 10/15/20 and expiring on 03/24/25. *Ishaq I. Chanda*

Ishaq I. Chanda, P.E.
Product Control Unit Supervisor
NOA No. 25-0102.02
Expiration Date: March 24, 2030
Approval Date: January 16, 2025

PGT Industries, LLC

NOTICE OF ACCEPTANCE: EVIDENCE SUBMITTED

3. NEW EVIDENCE SUBMITTED

A. DRAWINGS

1. Drawing No. **PGT0005 Rev J**, titled “Aluminum Sliding Glass Door (SM)”, sheets 1 through 10 of 10, dated 03/21/20 and last revised on 12/20/2024, prepared by manufacturer, signed and sealed by Anthony Lynn Miller, P.E.

B. TESTS

1. None.

C. CALCULATIONS

1. None.

D. QUALITY ASSURANCE

1. Miami-Dade Department of Regulatory and Economic Resources (RER)

E. MATERIAL CERTIFICATIONS

1. Notice of Acceptance No. **24-0915725.02** issued to **Kuraray America, Inc.** for their “**Trosifol® Ultraclear, Clear and Color PVB Glass Interlayers**”, expiring on 07/08/29.

F. STATEMENTS

1. Statement letter of conformance, complying with **FBC 8th Edition (2023)**, and statement letter of no financial interest, dated 12/18/24, signed and sealed by Anthony Lynn Miller, P.E.
2. Statement letter dated 12/18/24 issued by manufacturer requesting renewal with company name change to PGT industries, LLC, signed and sealed by Anthony Lynn Miller, P.E.
3. e-mail dated 12/23/24 sent by Lynn Miller (PGT Code Compliance Manager), consists of PGT innovation form 8-k filed w/SEC, PGT innovation form 10-K filed w/SEC and Exhibit 21(Form 10-K); PGT innovation’s list of subsidiaries.

G. OTHERS

1. Article of conversion of PGT Industries, Inc to PGT industries, LLC pdf provided on 12/24/24 by Ms. April Lee, Assistant General Counsel.
2. Florida Department of State, Division of Corporation listing # L2400142070 of PGT Industries, LLC as active status since 12/17/24.
3. Florida Department of State, Division of Corporation listing # F03387 of PGT Industries, Inc as Inactive status.
4. PGT Name change organization chart layout prepared by RER (for file use only).
5. This NOA revises & renews NOA No. **23-0710.06** (PGT Industries, Inc.), expires on 03/24/30.

Ishaq I. Chanda

Ishaq I. Chanda, P.E.
Product Control Unit Supervisor
NOA No. 25-0102.02
Expiration Date: March 24, 2030
Approval Date: January 16, 2025

SERIES 770 HP, SMALL MISSILE IMPACT RESISTANT SLIDING GLASS DOOR

1) THIS PRODUCT HAS BEEN DESIGNED & TESTED TO COMPLY WITH THE REQUIREMENTS OF THE FLORIDA BUILDING CODE, INCLUDING THE HIGH VELOCITY HURRICANE ZONE (HVHZ).

2) SHUTTERS ARE NOT REQUIRED 30' ABOVE GRADE IN WIND-BORNE DEBRIS REGION. FOR INSULATED GLASS INSTALLATIONS ABOVE 30' IN THE HVHZ, THE OUTBOARD LITE (CAP) MUST BE TEMPERED.

3) FOR MASONRY APPLICATIONS IN MIAMI-DADE COUNTY, USE ONLY MIAMI-DADE COUNTY APPROVED MASONRY ANCHORS. MATERIALS USED FOR ANCHOR EVALUATIONS WERE SOUTHERN PINE, ASTM C90 CONCRETE MASONRY UNITS AND CONCRETE WITH MIN. KSI PER ANCHOR TYPE.

4) ALL WOOD BUCKS LESS THAN 1-1/2" THICK ARE TO BE CONSIDERED 1X INSTALLATIONS. 1X WOOD BUCKS ARE OPTIONAL IF UNIT IS INSTALLED DIRECTLY TO SUBSTRATE. WOOD BUCKS DEPICTED AS 2X ARE 1-1/2" THICK OR GREATER. 1X AND 2X BUCKS (WHEN USED) SHALL BE DESIGNED AND SECURED TO PROPERLY TRANSFER LOADS TO THE STRUCTURE. WOOD BUCK DESIGN AND INSTALLATION IS THE RESPONSIBILITY OF THE ENGINEER, (EOR) OR ARCHITECT OF RECORD, (AOR).

5) ANCHOR EMBEDMENT TO BASE MATERIAL SHALL BE BEYOND WALL DRESSING OR STUCCO. USE ANCHORS OF SUFFICIENT LENGTH TO ACHIEVE REQUIRED MIN. EMBEDMENT. SILL ANCHORS MUST BE SEALED. INSTALLATION SCREWS, FRAME AND PANEL CORNERS TO BE SEALED WITH NARROW JOINT SEALANT. OVERALL SEALING/FLASHING STRATEGY FOR WATER RESISTANCE OF INSTALLATION SHALL BE DONE BY OTHERS AND IS BEYOND THE SCOPE OF THESE INSTRUCTIONS.

6) 1/4" MAX. SHIMS ARE REQUIRED AT EACH ANCHOR LOCATION WHERE THE PRODUCT IS NOT FLUSH TO THE SUBSTRATE. USE SHIMS CAPABLE OF TRANSFERRING APPLIED LOADS.

7) DESIGN PRESSURES:

- A. NEGATIVE DESIGN LOADS BASED ON STRUCTURAL TESTING AND GLASS PER ASTM E1300.
- B. POSITIVE DESIGN LOADS BASED ON WATER TEST PRESSURE, STRUCTURAL TESTING AND GLASS PER ASTM E1300.
- C. DESIGN LOADS ARE BASED ON ALLOWABLE STRESS DESIGN, ASD.

8) THE ANCHORAGE METHODS SHOWN HAVE BEEN DESIGNED TO RESIST THE WINDLOADS CORRESPONDING TO THE REQUIRED DESIGN PRESSURE. THE 33-1/3% STRESS INCREASE HAS NOT BEEN USED IN THE DESIGN OF THIS PRODUCT. THE 1.6 LOAD DURATION FACTOR WAS USED FOR THE EVALUATION OF ANCHORS INTO WOOD. ANCHORS THAT COME INTO CONTACT WITH OTHER DISSIMILAR MATERIALS SHALL MEET THE REQUIREMENTS OF THE FLORIDA BUILDING CODE FOR CORROSION RESISTANCE.

9) METAL SUBSTRATE TO MEET MIN. STRENGTH AND THICKNESS REQUIREMENTS PER CURRENT FLORIDA BUILDING CODE AND TO BE REVIEWED BY THE AUTHORITY HAVING JURISDICTION.

10) APPLICABLE EGRESS REQUIREMENTS TO BE REVIEWED BY BUILDING OFFICIAL.

11) IF SILL IS TIGHT TO SUBSTRATE, GROUT OR OTHER MATERIAL IS NOT REQUIRED. IF USED, NON-SHRINK, NON-METALLIC GROUT, MAX. 1/4" THICK & 3400 PSI MIN., (DONE BY OTHERS) MUST FULLY SUPPORT THE ENTIRE LENGTH OF THE SILL THAT IS NOT TIGHT TO THE SUBSTRATE, AND TRANSFER SHEAR LOAD TO SUBSTRATE. IF SUBSTRATE IS WOOD, 30# FELT PAPER OR MASTIC IS REQUIRED BETWEEN THE GROUT AND WOOD SUBSTRATE, OR AS APPROVED BY THE AUTHORITY HAVING JURISDICTION.

12) REFERENCES: TEST REPORTS FTL-5998, FTL-6005, FTL-7468, FTL-6012 & FTL-7825; DEWALT ULTRACON+ NOA; ELCO ULTRACON NOA; DEWALT/ELCO CRETEFLEX NOA AND AGGREGATOR NOA

DESIGN PRESSURE RATING	IMPACT RATING
SEE TABLE 1 ON SHEET 4	RATED FOR SMALL MISSILE IMPACT RESISTANCE

TABLE A:

Anchor Group	Anchor Type	Frame Member	Substrate	Min. Edge Distance	Min. O.C. Distance	Min. Embedment or Metal Thickness
A	#12 18-8 or 410 SS SMS	All	Southern Pine (SG = 0.55)	9/16"	7/8"	1-3/8"
			6063-T5 Aluminum	3/8"	9/16"	0.071" (20 Ga)
			A36 Steel	3/8"	9/16"	0.050"
			Gr. 33 Steel Stud	3/8"	9/16"	0.045" (18 Ga)
	1/4" Elco Aggre-Gator	All	Concrete (min. 2.22 ksi)	1-1/2"	3"	1-3/8"
		Jamb	Filled Block (ASTM C90)	2"	3"	2"
Jamb		Hollow Block (ASTM C90)	2"	3"	1-1/4"	
B	#12 Steel SMS (Gr. 5)	All	Southern Pine (SG = 0.55)	9/16"	7/8"	1-3/8"
			6063-T5 Aluminum	3/8"	9/16"	0.071" (20 Ga)
			A36 Steel	3/8"	9/16"	0.050"
			Gr. 33 Steel Stud	3/8"	9/16"	0.045" (18 Ga)
C	1/4" DeWalt UltraCon+	Head / Sill	Concrete (min. 3 ksi)	1-5/16"	4"	1-3/8"
		Jamb	Concrete (min. 3 ksi)	1"	4"	1-3/8"
		Jamb	Hollow Block (ASTM C90)	1"	3"	1-1/4"
		All	Southern Pine (SG = 0.55)	1"	1"	1-3/8"
D	1/4" 410 SS Elco CreteFlex	Head / Sill	Concrete (min. 3.35 ksi)	1"	4"	1-3/4"
		Jamb	Concrete (min. 3.35 ksi)	1"	6"	1-3/4"
		Jamb	Hollow Block (ASTM C90)	2-1/2"	6"	1-1/4"
		All	Southern Pine (SG = 0.55)	1"	1"	1-3/8"

- 1) WHERE SUBSTRATE CONDITIONS REQUIRE ANCHORAGE FROM MORE THAN ONE OF THE ANCHOR GROUPS ABOVE, CHOOSE THE ANCHOR GROUP OF THE LOWEST LETTER FOR ALL TABLES IN THIS APPROVAL.
- 2) ALL ANCHOR HEAD TYPES ARE APPLICABLE.
- 3) FOR THE MINIMUM STRENGTHS OF ANCHORS AND SUBSTRATES, SEE TABLE 3, SHEET 9.
- 4) HOLLOW BLOCK VALUES MAY ALSO BE USED IN FILLED BLOCK APPLICATIONS.
- 5) ANCHORS MUST BE OF SUFFICIENT LENGTH SO THAT A MINIMUM OF 3 THREADS EXTEND BEYOND METAL SUBSTRATE.

DLO WIDTH = NOM. PANEL WIDTH - 7"
 PANEL HEIGHT = DOOR UNIT HEIGHT - 1-7/8"
 DLO HEIGHT = DOOR UNIT HEIGHT - 10-1/8"
 DLO HEIGHT = PANEL HEIGHT - 8-1/4"

CODES / STANDARDS USED:

- 2023 FLORIDA BUILDING CODE (FBC), 8TH EDITION
- ASTM E1300-09
- ANSI/AF&PA NDS-2018 FOR WOOD CONSTRUCTION
- ALUMINUM DESIGN MANUAL, ADM-2020
- AISI S100-16
- AISC 360-16

GENERAL NOTES.....	1
ELEVATIONS.....	2
GLAZING DETAILS.....	3
DESIGN PRESSURES.....	4
ELEVATION.....	5
INSTAL. SECTIONS.....	6
ANCHOR LAYOUT.....	7
ASSEMBLY SECTIONS....	8
PARTS LIST.....	9
EXTRUSIONS.....	10

PRODUCT RENEWED
 as complying with the Florida Building Code
 NOA-No. 25-0102.02
 Expiration Date 03/24/2030
 By Isaac L. Chan
 Miami-Dade Product Control

REVISED CO. ADDRESS
 JR - 12/20/24

PREPARED BY A. LYNN MILLER 1070 TECHNOLOGY DRIVE N. VENICE, FL 34275 (941) 480-1600	REGISTRATION #29296	Date	03/21/20	J Rev
		By	JENS ROSOWSKI	
 Custom Windows and Doors 3400 PRECISION DRIVE N. VENICE, FL 34275 (941) 480-1600	ALUMINUM SLIDING GLASS DOOR (SM)	ANCHOR TYPES & GEN. NOTES	No.	PGT0005
			Sheet	1 OF 10
		Series	SGD770 HP	

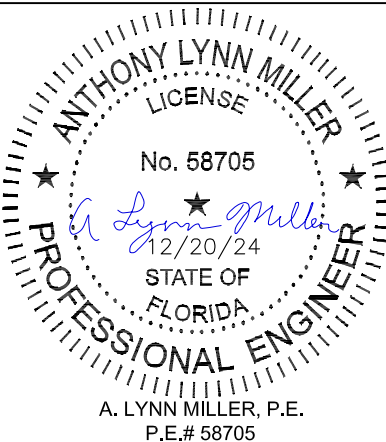

A. LYNN MILLER, P.E.
 P.E.# 58705

EXAMPLE CONFIGURATIONS

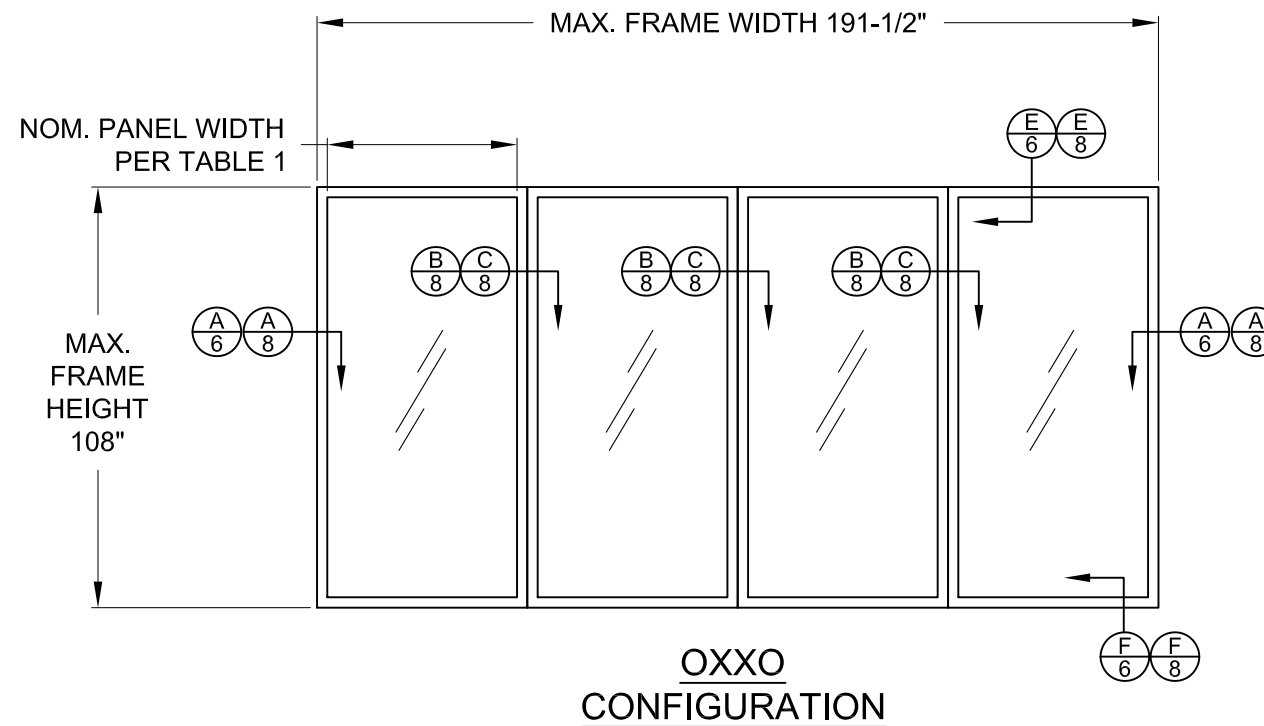
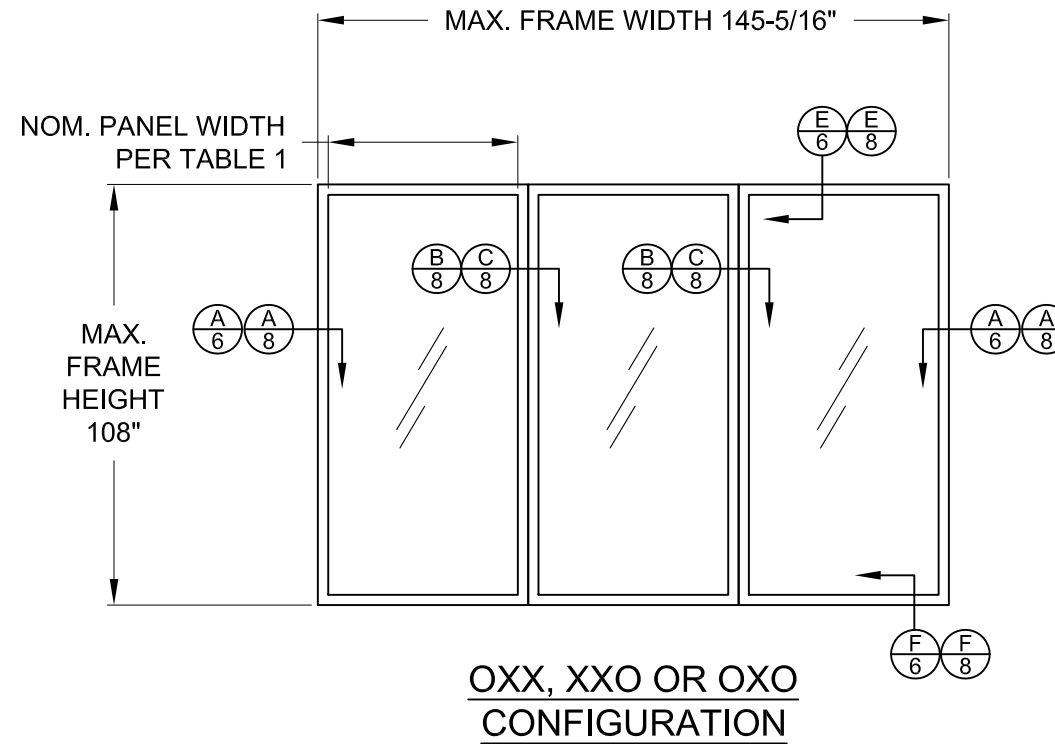
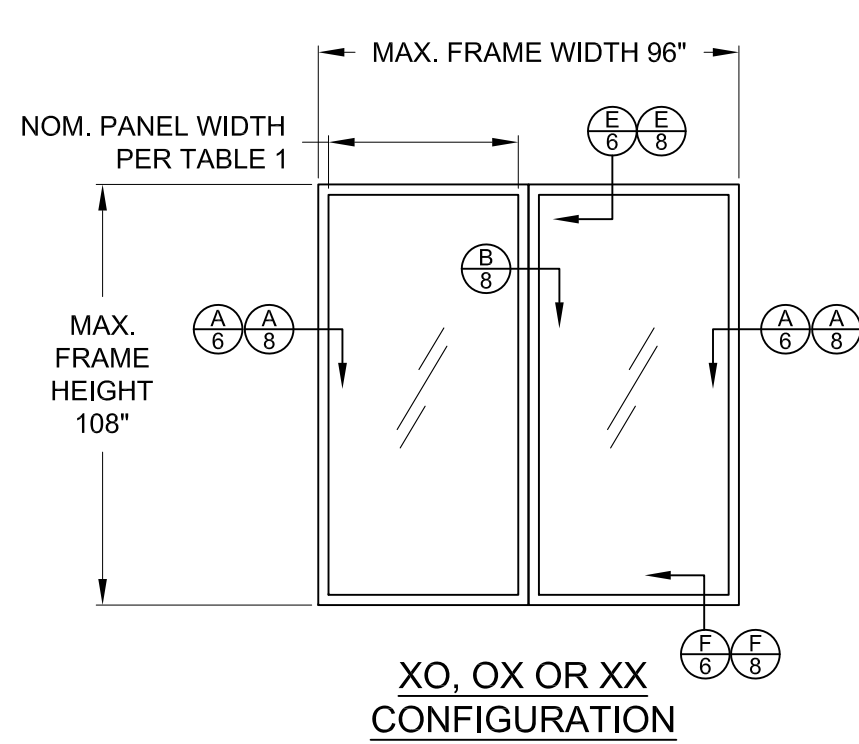

DLO WIDTH = NOM. PANEL WIDTH - 7"
 PANEL HEIGHT = DOOR UNIT HEIGHT - 1-7/8"
 DLO HEIGHT = DOOR UNIT HEIGHT - 10-1/8"
 DLO HEIGHT = PANEL HEIGHT - 8-1/4"

PRODUCT RENEWED
 as complying with the Florida
 Building Code
 NOA-No. 25-0102.02
 Expiration Date 03/24/2030
 By *Ishay I. Chank*
 Miami-Dade Product Control

Revision:
 REVISED CO. ADDRESS
 JR - 12/20/24

PREPARED BY A. LYNN MILLER 1070 TECHNOLOGY DRIVE N. VENICE, FL 34275 (941) 480-1600	REGISTRATION #29296	Date	03/21/20
		By	JENS ROSOWSKI
 Custom Windows and Doors 3400 PRECISION DRIVE N. VENICE, FL 34275 (941) 480-1600	ALUMINUM SLIDING GLASS DOOR (SM)	DWG No.	PGT0005
		Series	J
EXAMPLE CONFIGURATIONS	SGD770 HP	2 OF 10	Sheet

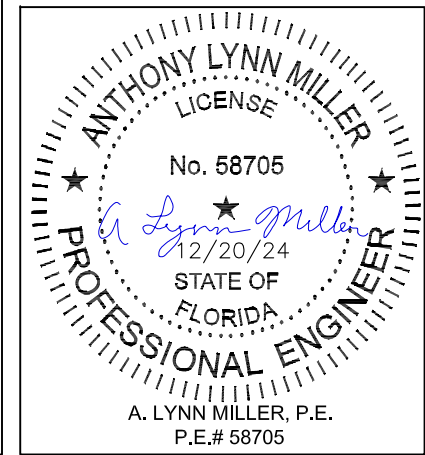

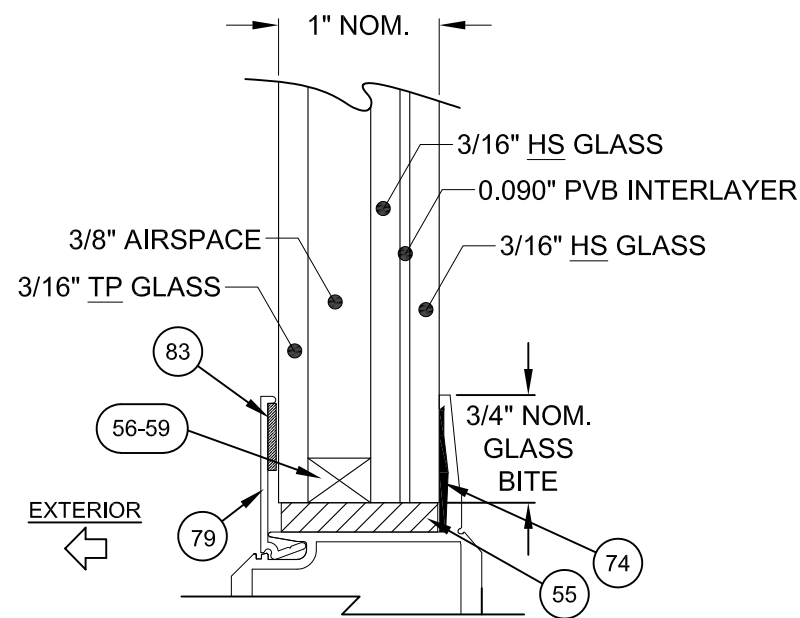

1" LAMINATED INSULATING GLASS
TYPE G9

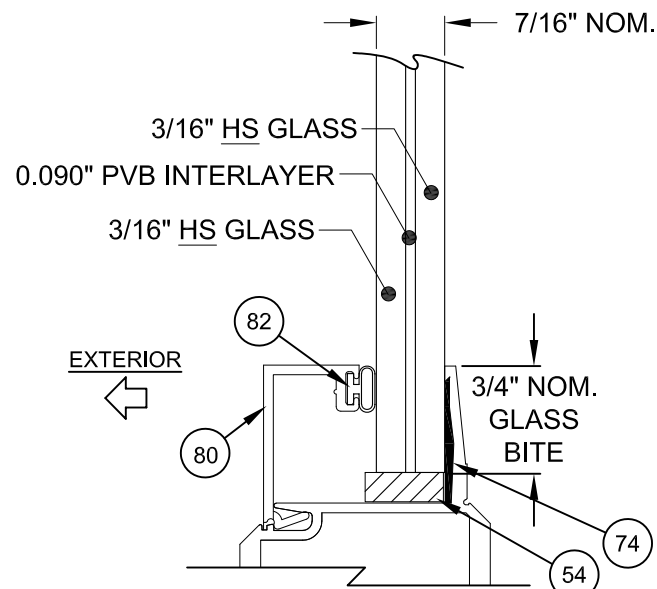

7/16" LAMINATED GLASS
TYPE G10

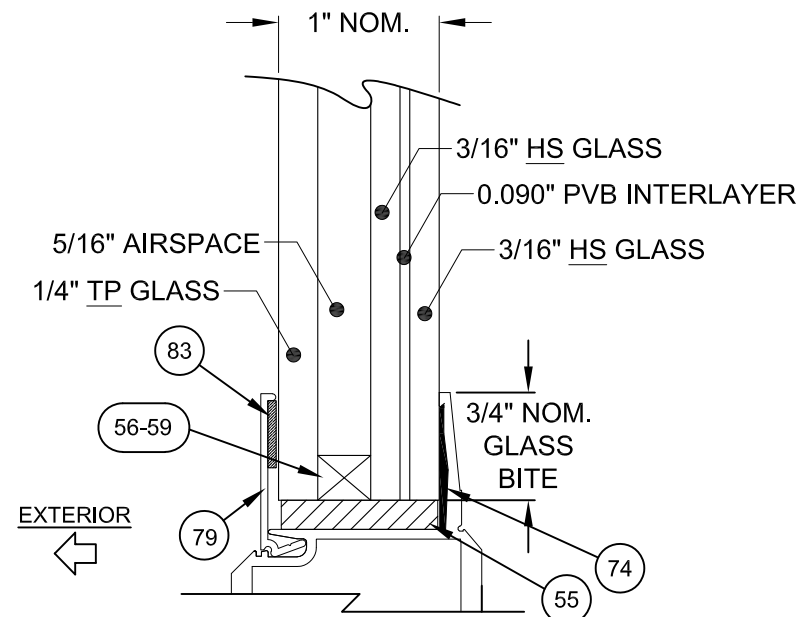

1" LAMINATED INSULATING GLASS
TYPE G9A

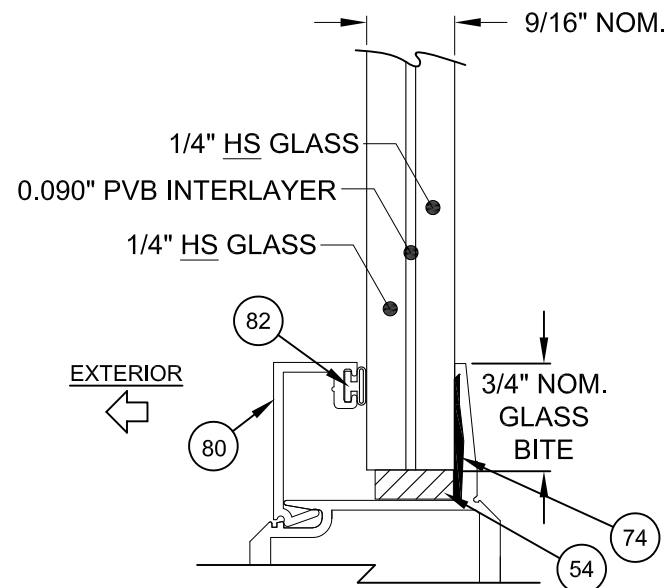

9/16" LAMINATED GLASS
TYPE G10A

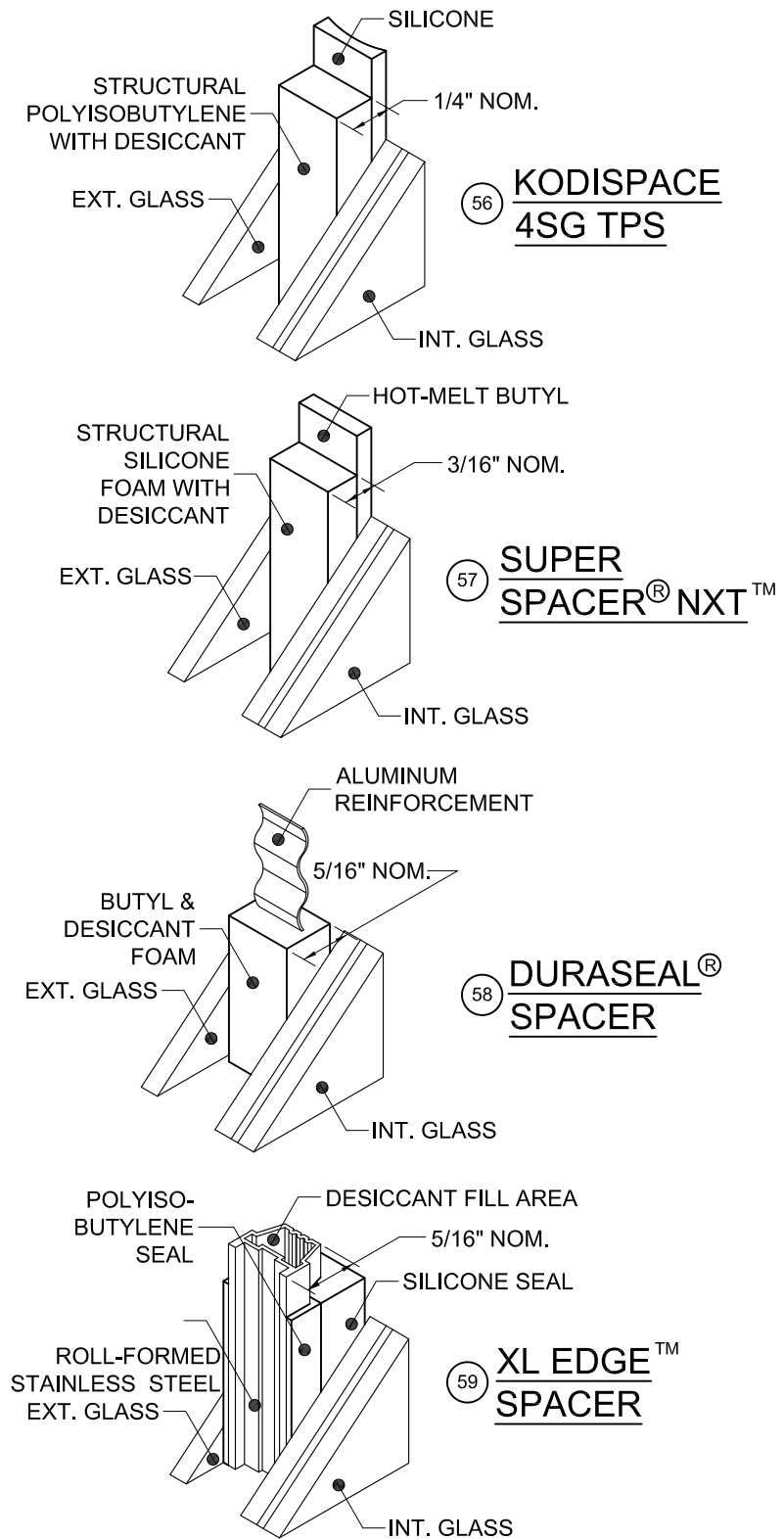

Part #	Description	Material
56	Kommerling 4SG TPS Spacer System	See this Sheet for Materials
57	Quanex Super Spacer nXT with Hot Melt Butyl	
58	Quanex Duraseal Spacer	
59	Cardinal XL Edge Spacer	

REFERENCE TEST REPORTS: FTL-8717, 8968 & 8970

PRODUCT RENEWED
as complying with the Florida
Building Code
NOA-No. 25-0102.02
Expiration Date 03/24/2030
By *Ishag I. Lhank*
Miami-Dade Product Control

Revised: REVISED CO. ADDRESS
JR - 12/20/24

PREPARED BY A. LYNN MILLER 1070 TECHNOLOGY DRIVE N. VENICE, FL 34275 (941) 480-1600	REGISTRATION #29296	Date	03/21/20	
		By	JENS ROSOWSKI	
 Custom Windows and Doors 3400 PRECISION DRIVE N. VENICE, FL 34275 (941) 480-1600	ALUMINUM SLIDING GLASS DOOR (SM)	No.	3 OF 10	
		Sheet	3 OF 10	
GLAZING DETAILS	Drawn	JENS ROSOWSKI	Rev.	J
SGD770 HP	Desc.	PGT0005		

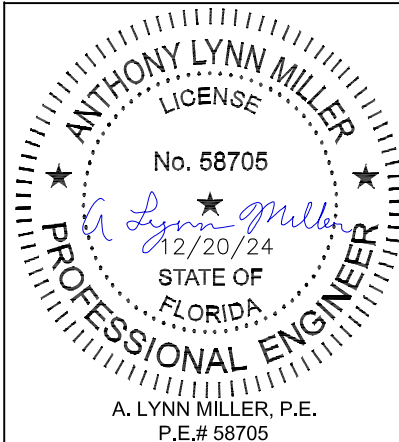

"AN" = ANNEALED
"HS" = HEAT STRENGTHENED
"TP" = TEMPERED
"PVB" = TROSIFOL® PVB INTERLAYER BY KURARAY AMERICA, INC.

TABLE 1:

Design Pressure (DP) and Anchor Quantities Required

(For all approved Configurations, Sheet 2 and Glass Types, Sheet 3)

Reinforced Interlocks Heavy-duty Astragal Heavy-duty Stiles			Frame Height																								
			80"				84"				90"				98"				102"				108"				
			69-7/8" DLO				73-7/8" DLO				79-7/8" DLO				87-7/8" DLO				91-7/8" DLO				97-7/8" DLO				
			Anchor Group				Anchor Group				Anchor Group				Anchor Group				Anchor Group								
			A	B	C	D	A	B	C	D	A	B	C	D	A	B	C	D	A	B	C	D	A	B	C	D	
Nominal Panel Width (in)	24"	17" DLO	Design Pressure	+90/-130				+90/-130				+90/-130				+90/-130				+90/-130				+90/-130			
			Head/Sill	C5+2	C5+2	C5+2	C5+2	C5+2	C5+2	C5+2	C5+2	C5+2	C5+2	C5+2	C5+2	C5+2	C5+2	C5+2	C5+2	C5+2	C5+2	C5+2	C5+2	C5+2	C5+2	C5+2	C5+2
			Jamb	10	8	8	8	10	8	8	8	10	10	10	10	12	10	10	10	12	10	10	10	14	10	10	10
	30"	23" DLO	Design Pressure	+90/-130				+90/-130				+90/-130				+90/-130				+90/-130				+90/-130			
			Head/Sill	C5+2	C5+2	C5+2	C5+2	C5+2	C5+2	C5+2	C5+2	C5+2	C5+2	C5+2	C5+2	C6+2	C6+2	C6+2	C6+2	C6+2	C6+2	C6+2	C6+2	C6+2	C6+2	C6+2	C6+2
			Jamb	12	10	8	8	12	10	8	8	12	10	10	10	14	12	10	10	14	12	10	10	16	12	10	10
	36"	29" DLO	Design Pressure	+90/-130				+90/-130				+90/-130				+90/-130				+90/-130				+90/-130			
			Head/Sill	C5+2	C5+2	C5+2	C5+2	C6+2	C6+2	C5+2	C5+2	C6+2	C6+2	C6+2	C6+2	C7+2	C7+2	C6+2	C6+2	C7+2	C7+2	C7+2	C7+2	C7+2	C7+2	C7+2	C7+2
			Jamb	12	10	8	8	14	12	8	8	14	12	10	10	16	14	10	10	18	14	10	10	18	14	12	10
	42"	35" DLO	Design Pressure	+90/-130				+90/-130				+90/-130				+90/-130				+90/-130				+90/-121.4			
			Head/Sill	C6+2	C6+2	C6+2	C6+2	C6+2	C6+2	C6+2	C6+2	C7+2	C7+2	C6+2	C6+2	C7+2	C7+2	C7+2	C7+2	C8+2	C8+2	C7+2	C7+2	C8+2	C8+2	C7+2	C7+2
			Jamb	14	12	8	8	16	12	10	8	16	14	10	10	18	14	12	10	20	16	12	10	20	16	12	10
	48"	41" DLO	Design Pressure	+90/-130				+90/-130				+90/-130				+90/-130				+90/-118.5				+90/-110			
			Head/Sill	C6+3	C6+3	C6+3	C6+3	C7+3	C7+3	C6+3	C6+3	C7+3	C7+3	C7+3	C7+3	C8+3	C8+3	C8+3	C8+3	C8+3	C8+3	C7+3	C7+3	C8+3	C8+3	C7+2	C7+2
			Jamb	16	12	10	8	16	14	10	8	18	14	12	10	20	16	12	10	20	16	12	10	20	16	12	10

NOTE: JAMB ANCHORS ARE SPECIFIED AS THE TOTAL QUANTITY, DIVIDE BY 2 FOR PAIRS TO BE INSTALLED.

EXAMPLE ON SHEET 5

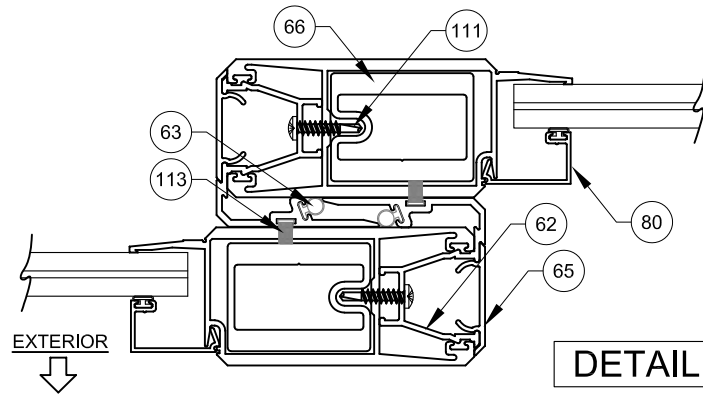

DETAIL B

DETAIL B
ALL INTERLOCKS TO BE REINFORCED

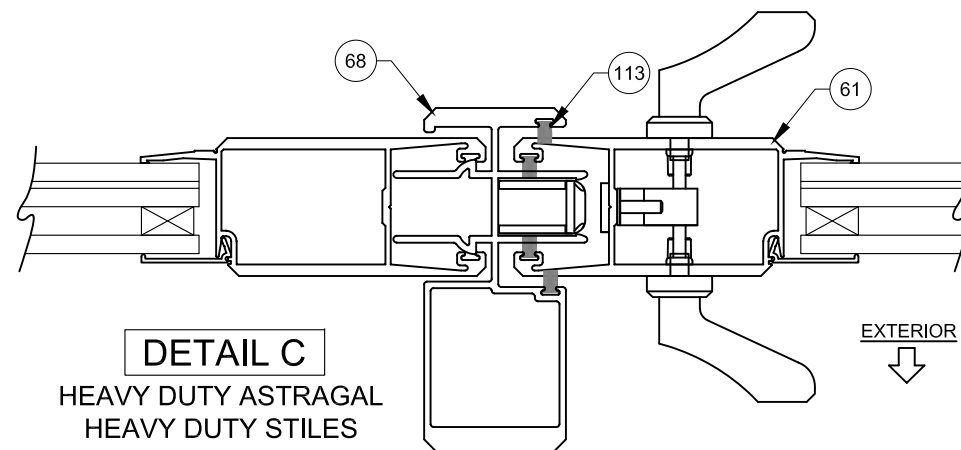

DETAIL C

DETAIL C
HEAVY DUTY ASTRAGAL
HEAVY DUTY STILES

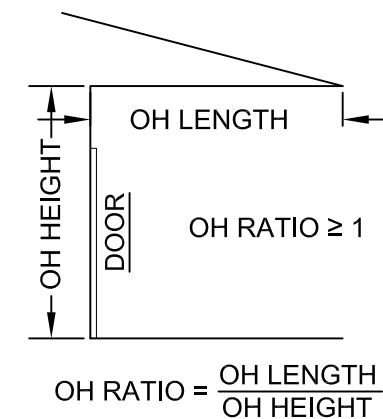

1) POSITIVE PRESSURES IN TABLE ARE BASED ON THE USE OF THE 4" SILL.

2) WHEN USING THE 2 1/2" SILL, POSITIVE DP IS 46.67 PSF MAX. AND WITH THE 3 1/4" SILL, POSITIVE PRESSURES IS 60.0 PSF MAX. (NEGATIVE PRESSURES UNCHANGED). SEE TABLE 1A ON THIS SHEET.

3) 2-1/2", 3-1/4" AND 4" SILL HEIGHTS ARE TESTED FOR WATER INFILTRATION WHEREAS THE 1-1/2" SILL IS NOT AND MUST ONLY BE USED WHERE WATER RESISTANCE IS NOT REQUIRED. POSITIVE DESIGN PRESSURES SHOWN IN TABLE 1 MAY BE USED WHEN THE DOOR IS PROTECTED BY AN OVERHANG COMPLYING WITH THE FLORIDA BUILDING CODE (SEE ADJACENT DIAGRAM); THIS CONDITION IS NOT RATED FOR WATER INFILTRATION.

4) SEE SHEETS 6 & 7 FOR ANCHORAGE SPACING AND EMBEDMENT INFORMATION. DOOR SIZE TO COMPLY WITH FBC EGRESS REQUIREMENTS.

DLO WIDTH = NOM. PANEL WIDTH - 7"
 PANEL HEIGHT = DOOR UNIT HEIGHT - 1-7/8"
 DLO HEIGHT = DOOR UNIT HEIGHT - 10-1/8"
 DLO HEIGHT = PANEL HEIGHT - 8-1/4"

TABLE 1A:

Sill Height to Max. (+) DP (Water Infiltration Rating)	
Sill Riser Height (Flat or Box, see Sheet 9)	(+) Design Pressure, psf
Flush - 1-1/2"	see note 3
Low - 2-1/2"	+ 46.67
Medium - 3-1/4"	+ 60.0
High - 4"	+ 90.0

SEE NOTES 1-3

PRODUCT RENEWED
 as complying with the Florida
 Building Code

NOA-No. 25-0102.02

Expiration Date 03/24/2030

By Isaac I. Chan
 Miami-Dade Product Control

REVISION: REVISED CO. ADDRESS
 JR - 12/20/24

PREPARED BY A. LYNN MILLER 1070 TECHNOLOGY DRIVE N. VENICE, FL 34275 (941) 480-1600	REGISTRATION #29296	Date	03/21/20
		Drawn By	JENS ROSOWSKI
 Custom Windows and Doors 3400 PRECISION DRIVE N. VENICE, FL 34275 (941) 480-1600	ALUMINUM SLIDING GLASS DOOR (SM)	No.	PGT0005
		Sheet	4 OF 10
DP & ANCHOR QUANTITY TABLE		Series	SGD770 HP

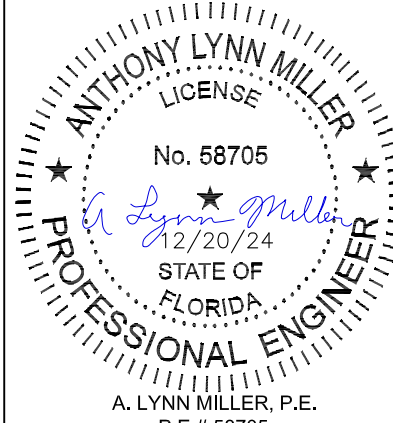

ANTHONY LYNN MILLER
 LICENSE
 No. 58705
 12/20/24
 STATE OF FLORIDA
 PROFESSIONAL ENGINEER
 A. LYNN MILLER, P.E.
 P.E.# 58705

EXAMPLE OXX ANCHORAGE PLAN:

(3) PANEL, 48" x 108" DOOR FROM TABLE ON SHEET 4, ANCHOR TYPES C IN CONCRETE SUBSTRATE

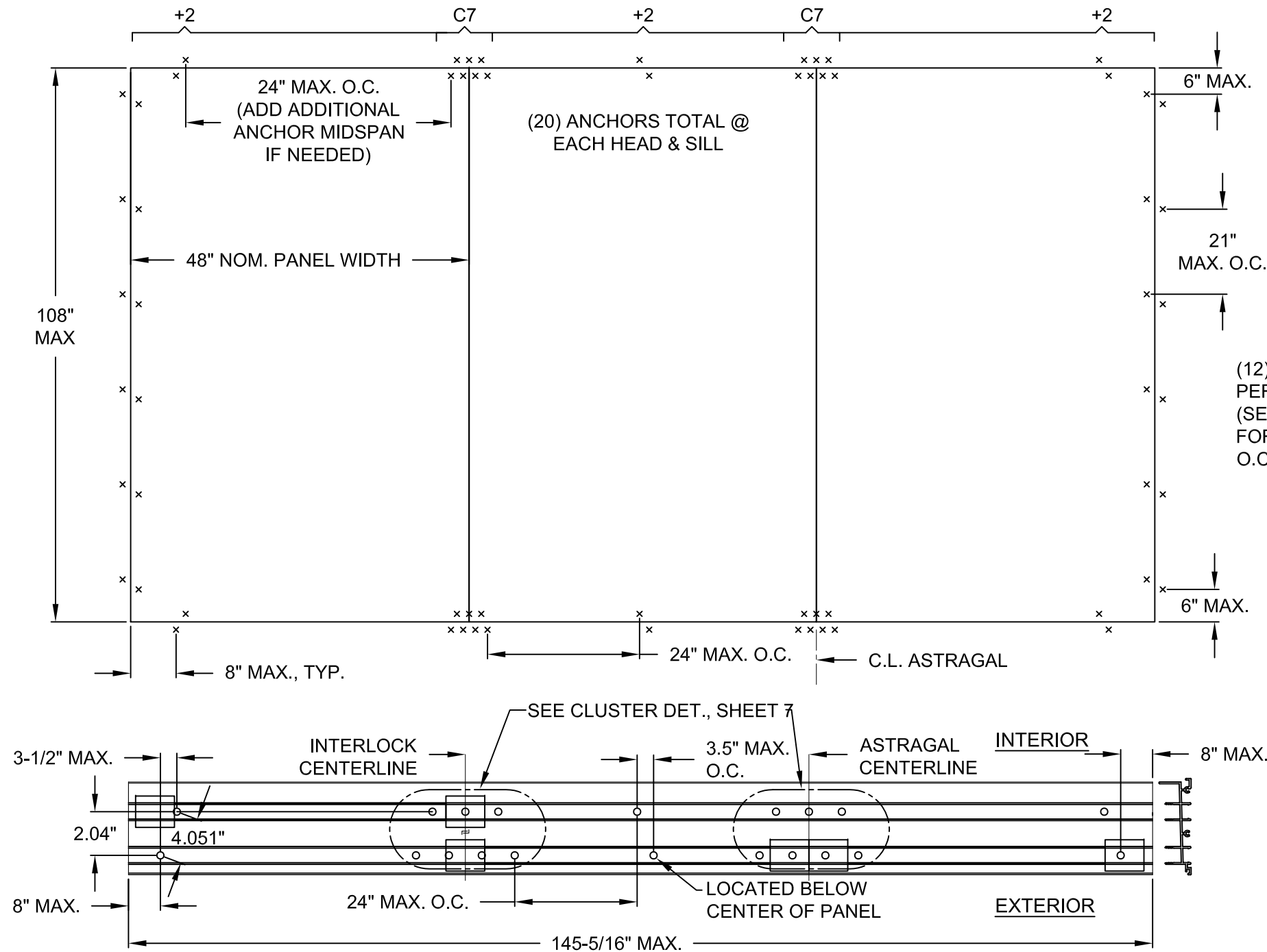

"ANCHORS PER PANEL" ARE THOSE AT THE HEAD AND SILL BETWEEN CLUSTERS OR THOSE BETWEEN A CLUSTER AND A FRAME JAMB.

ANCHORAGE REQUIREMENTS NOTES:

1. APPROVED ANCHOR TYPES: SEE TABLE A, SHEET 1.
2. ANCHOR LOCATION SPACING FOR ANCHOR QUANTITIES SPECIFIED IN TABLE 1 ON SHEET 4:

HEAD & SILL..... 8" MAX. FROM FRAME CORNERS. USE SPECIFIED CLUSTER FROM TABLE ON SHEET 4 AT EACH INTERLOCK AND ASTRAGAL LOCATION, PLUS SPECIFIED QUANTITY OF ADDITIONAL INTERMEDIATE ANCHORS PER PANEL (THE 8" FROM CORNER ANCHORS CAN BE INCLUDED). ADDITIONAL ANCHORS 24" MAX. ON CENTER. SEE EXAMPLE ANCHORAGE PLANS ABOVE AND EXAMPLE CLUSTERS AT ASTRAGAL / INTERLOCKS ON SHEET 7.

JAMBS..... 6" MAX. FROM BOTTOM AND 21" MAX. O.C. UTILIZING JAMB ANCHOR QUANTITIES FROM TABLE ON SHEET 4.

DLO WIDTH = NOM. PANEL WIDTH - 7"
 PANEL HEIGHT = DOOR UNIT HEIGHT - 1-7/8"
 DLO HEIGHT = DOOR UNIT HEIGHT - 10-1/8"
 DLO HEIGHT = PANEL HEIGHT - 8-1/4"

PRODUCT RENEWED
 as complying with the Florida Building Code
 NOA-No. 25-0102.02
 Expiration Date 03/24/2030
 By *Ishag I. Chank*
 Miami-Dade Product Control

REVISION: REVISED CO. ADDRESS JR - 12/20/24

PREPARED BY A. LYNN MILLER 1070 TECHNOLOGY DRIVE N. VENICE, FL 34275 (941) 480-1600	REGISTRATION #29296	Date	03/21/20	By JENS ROSOWSKI	PGT0005	Rev. J
		ALUMINUM SLIDING GLASS DOOR (SM)				
ELEVATION ANCHOR SPACING		No.	5 OF 10	Sheet		SGD770 HP
Custom Windows and Doors 3400 PRECISION DRIVE N. VENICE, FL 34275 (941) 480-1600		Title		Series		

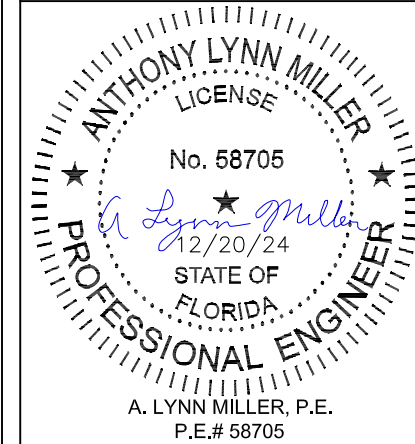

REVISION: Revised CO. ADDRESS
 JR - 12/20/24

PREPARED BY A. LYNN MILLER 1070 TECHNOLOGY DRIVE N. VENICE, FL 34275 (941) 480-1600	REGISTRATION #29296	Date	03/21/20
		Drawn By	JENS ROSOWSKI
ALUMINUM SLIDING GLASS DOOR (SM)	INSTAL. CROSS SECTIONS	No.	6 OF 10
		DWG	PGT0005
Custom Windows and Doors 3400 PRECISION DRIVE N. VENICE, FL 34275 (941) 480-1600	Sheet	SGD770 HP	Series

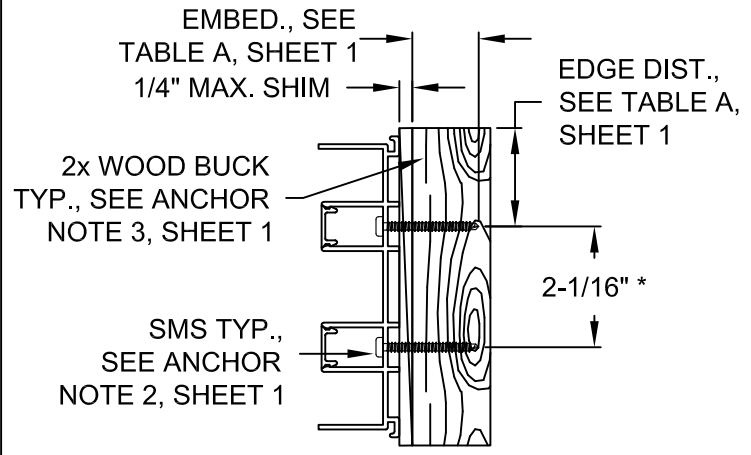
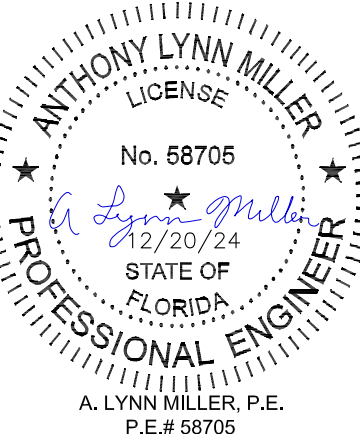

DETAIL A 2-TRACK FRAME JAMB
WOOD INSTALLATION

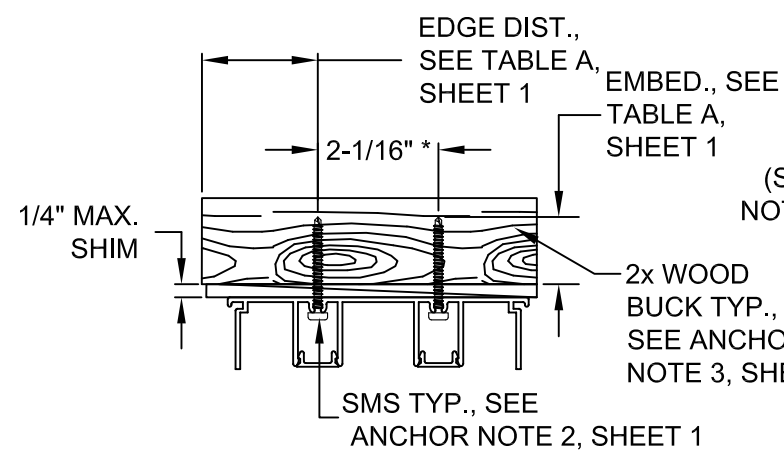

DETAIL E 2-TRACK FRAME HEAD
WOOD INSTALLATION

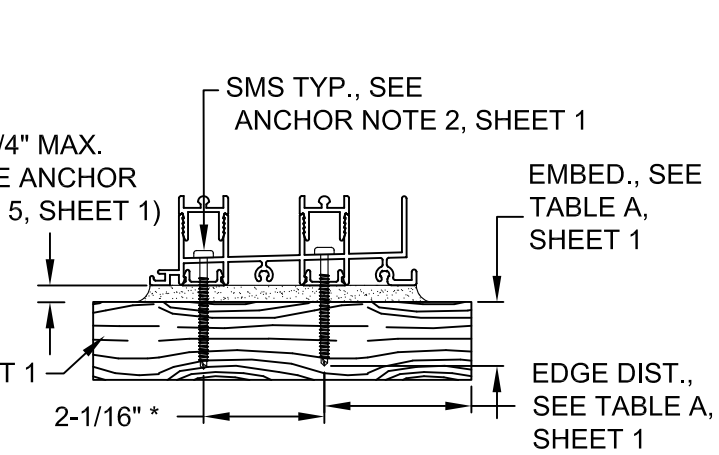

DETAIL F 2-TRACK FRAME SILL
WOOD INSTALLATION

- NOTES:**
- 1) ALL DIMENSIONS SHOWN ARE BASED ON MINIMUM ALLOWED.
 - 2) METAL SUBSTRATES SIMILAR TO WOOD SUBSTRATES AS SHOWN.
 - 3) ANCHORS MUST BE OF SUFFICIENT LENGTH SO THAT A MINIMUM OF 3 THREADS EXTEND BEYOND METAL SUBSTRATE.
 - 4) 1/4" SHIM MAY BE SHORTER THAN THE FRAME BUT MUST FULLY SUPPORT THE LOADS IMPOSED ON IT.

* DIAGONAL, O.C. DIMENSION IS 4.051" IN THE HEAD & SILL, 6" IN THE JAMB.

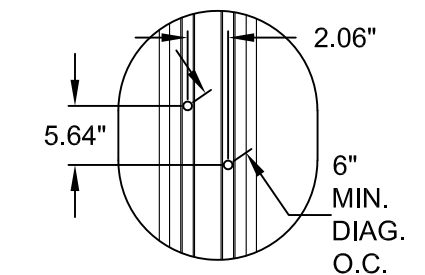

TYPICAL JAMB ANCHOR PAIR
FOR DETAIL "A", SEE ELEVATION FOR O.C. SPACING, SHEET 5.

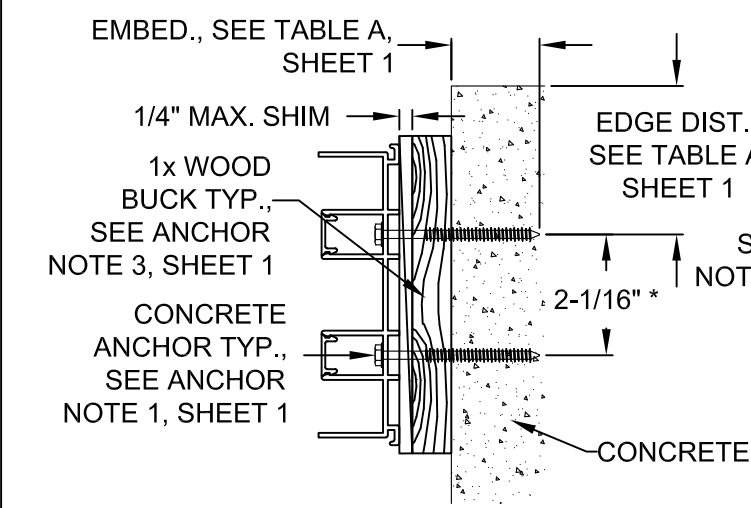

DETAIL A 2-TRACK FRAME JAMB
CONCRETE INSTALLATION

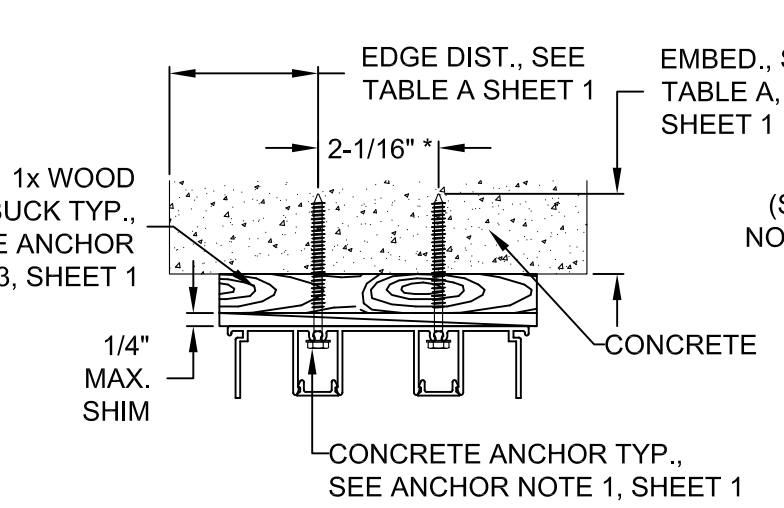

DETAIL E 2-TRACK FRAME HEAD
CONCRETE INSTALLATION

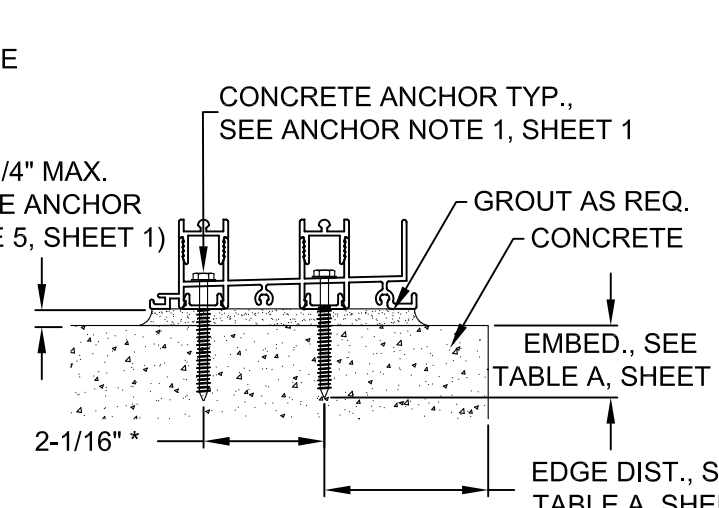

DETAIL F 2-TRACK FRAME SILL
CONCRETE INSTALLATION

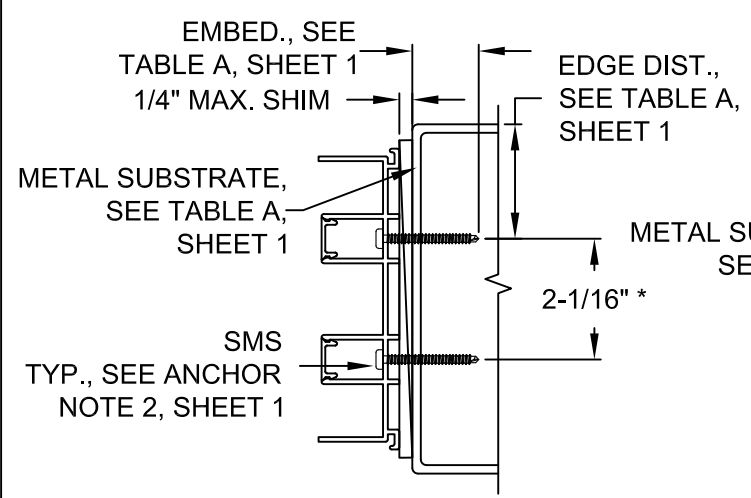

DETAIL A 2-TRACK FRAME JAMB
WOOD INSTALLATION

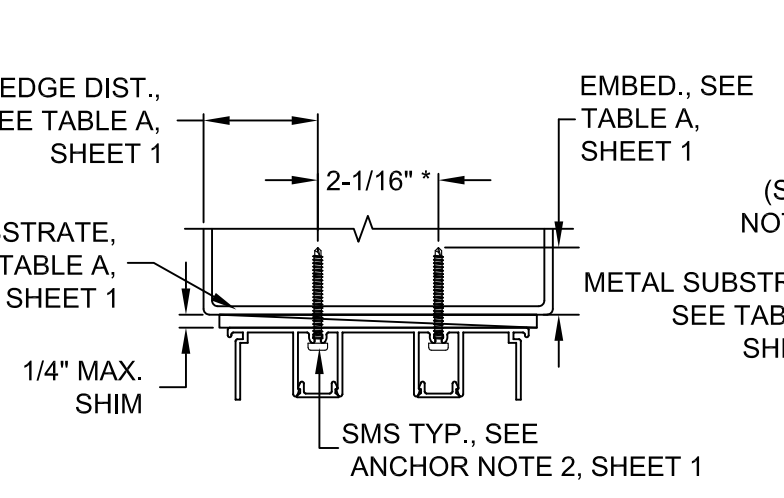

DETAIL E 2-TRACK FRAME HEAD
WOOD INSTALLATION

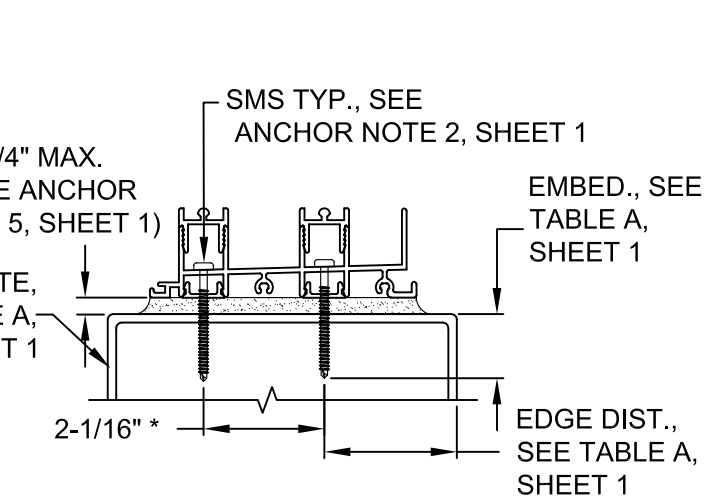

DETAIL F 2-TRACK FRAME SILL
WOOD INSTALLATION

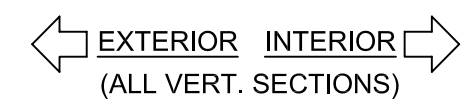

K	SINGLE INTERLOCK		LOCKSTILE
A	SINGLE INTERLOCK		LOCKSTILE
D	LOCKSTILE		SINGLE INTERLOCK
M	LOCKSTILE		SINGLE INTERLOCK
L (BOX OUT)	SINGLE INTERLOCK		ASTRAGAL OUT
LR (BOX OUT)	ASTRAGAL OUT		SINGLE INTERLOCK
N (BOX OUT)	ASTRAGAL IN		SINGLE INTERLOCK
C (BOX IN)	SINGLE INTERLOCK		ASTRAGAL IN
P	SINGLE INTERLOCK		FIXED LOCKSTILE
R	FIXED LOCKSTILE		SINGLE INTERLOCK
T (BOX OUT)	ASTRAGAL OUT		FIXED LOCKSTILE
T (BOX IN)	ASTRAGAL IN		FIXED LOCKSTILE
S (BOX OUT)	FIXED LOCKSTILE		ASTRAGAL OUT
S (BOX IN)	FIXED LOCKSTILE		ASTRAGAL IN

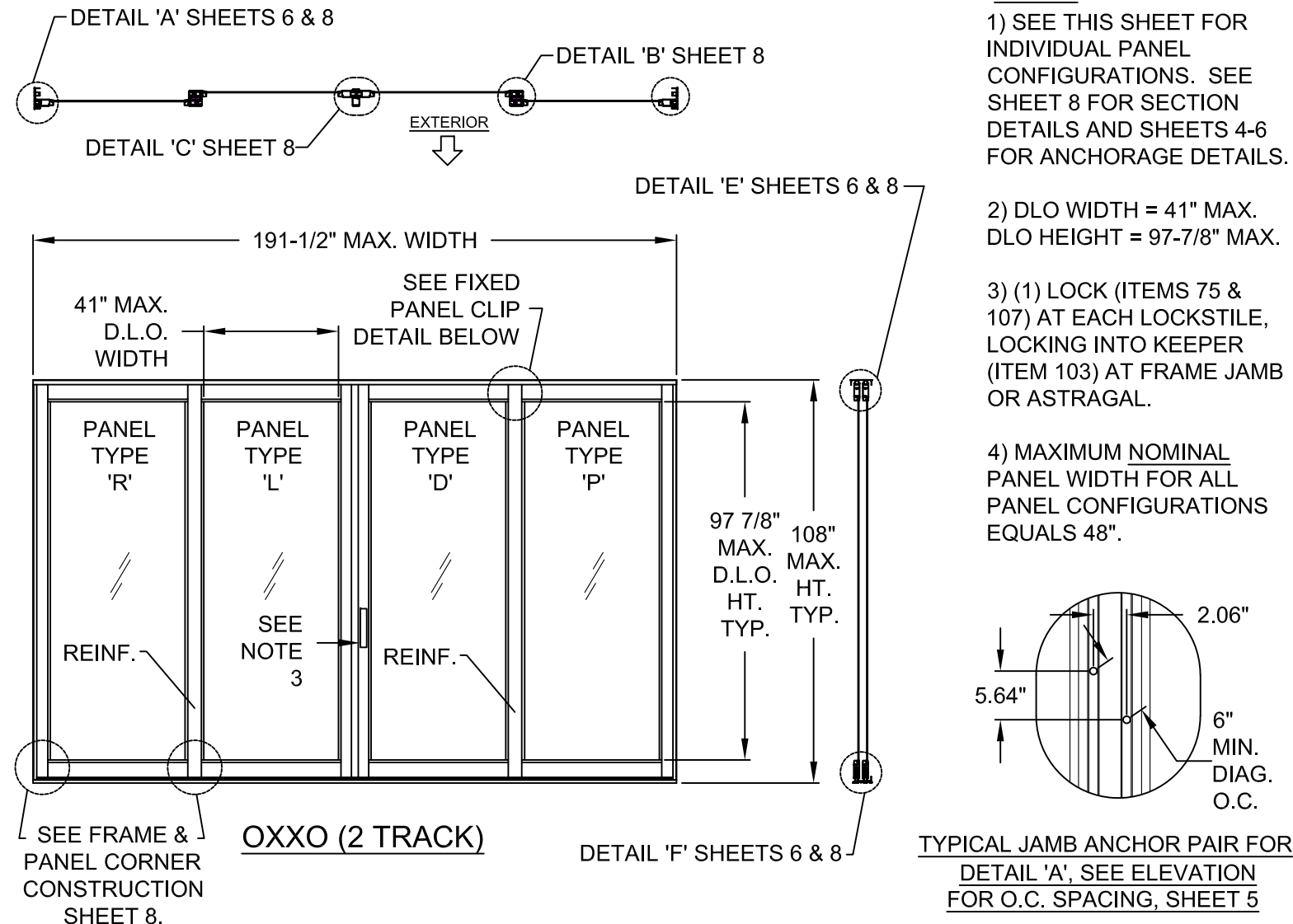

- NOTES:**
- 1) SEE THIS SHEET FOR INDIVIDUAL PANEL CONFIGURATIONS. SEE SHEET 8 FOR SECTION DETAILS AND SHEETS 4-6 FOR ANCHORAGE DETAILS.
 - 2) DLO WIDTH = 41" MAX.
DLO HEIGHT = 97-7/8" MAX.
 - 3) (1) LOCK (ITEMS 75 & 107) AT EACH LOCKSTILE, LOCKING INTO KEEPER (ITEM 103) AT FRAME JAMB OR ASTRAGAL.
 - 4) MAXIMUM NOMINAL PANEL WIDTH FOR ALL PANEL CONFIGURATIONS EQUALS 48".

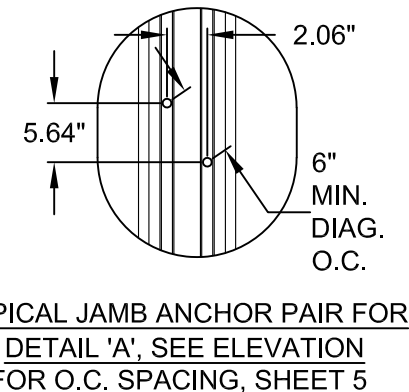

NOTE:
REINFORCEMENT REQUIRED AT ALL INTERLOCKS.

↑ INTERIOR
(ALL PANEL TYPES)
↓ EXTERIOR

- NOTES FOR FIGS 1-4**
- 1) ALL DIMENSIONS SHOWN ARE BASED ON MINIMUM ALLOWED.
 - 2) METAL SUBSTRATES SIMILAR TO WOOD SUBSTRATES AS SHOWN.
 - 3) DIAGONAL, O.C. DIMENSION IS 4.051" IN THE HEAD & SILL, 6" IN THE JAMB.

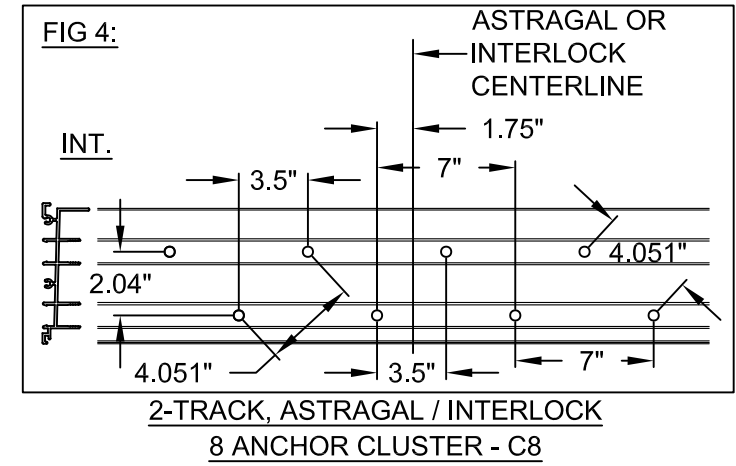
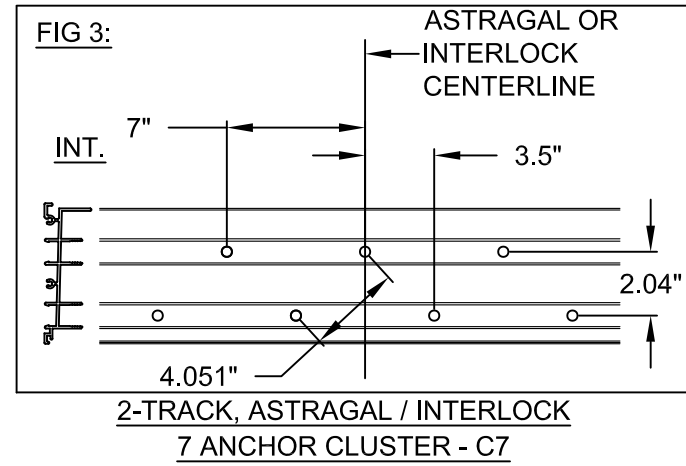
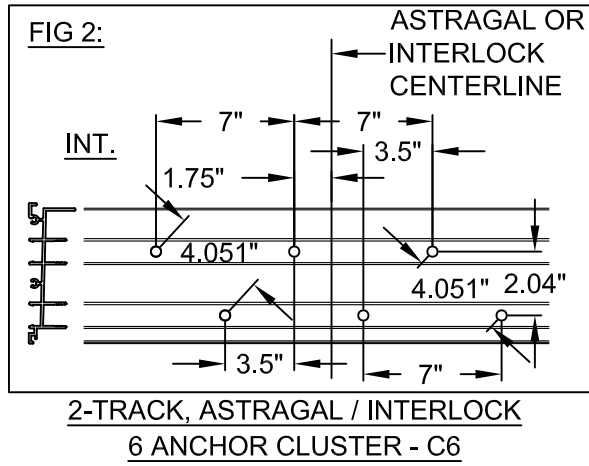
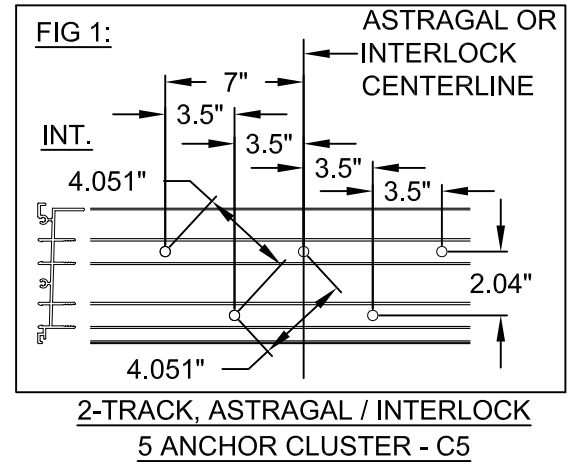

PRODUCT RENEWED
as complying with the Florida Building Code
NOA-No. 25-0102.02
Expiration Date 03/24/2030
By *Ishag I. Chank*
Miami-Dade Product Control

REVISED CO. ADDRESS
JR - 12/20/24

PREPARED BY A. LYNN MILLER 1070 TECHNOLOGY DRIVE N. VENICE, FL 34275 (941) 480-1600	REGISTRATION #29296	Date	03/21/20
		By	JENS ROSOWSKI
ALUMINUM SLIDING GLASS DOOR (SM)	PANEL TYPES & ANCH. LAYOUT	No.	7 OF 10
		DWG	PGT0005
SGD770 HP		Rev.	J

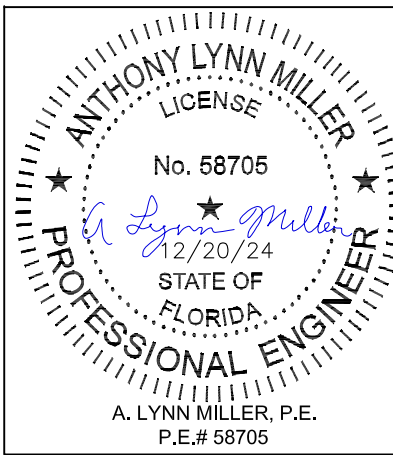

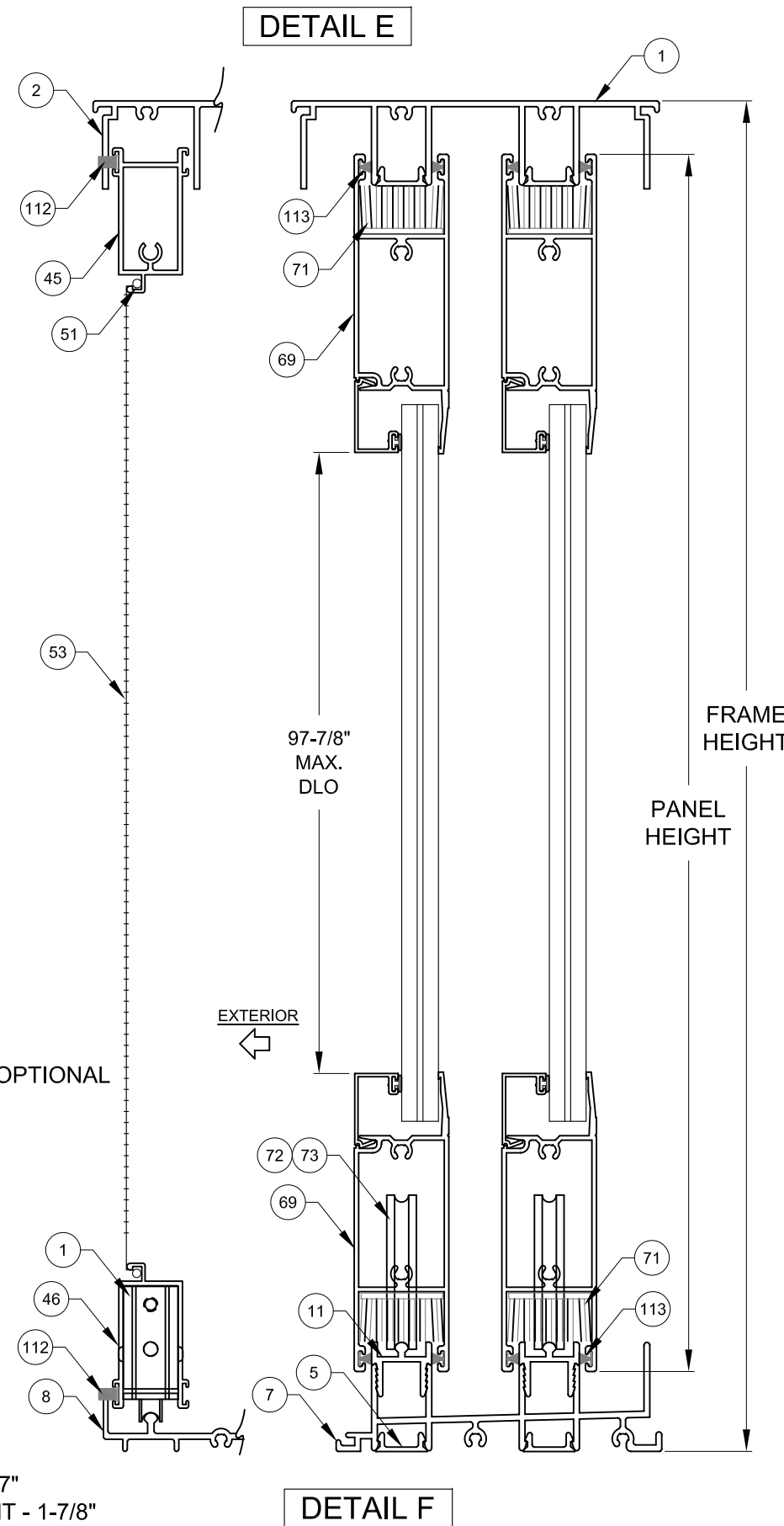
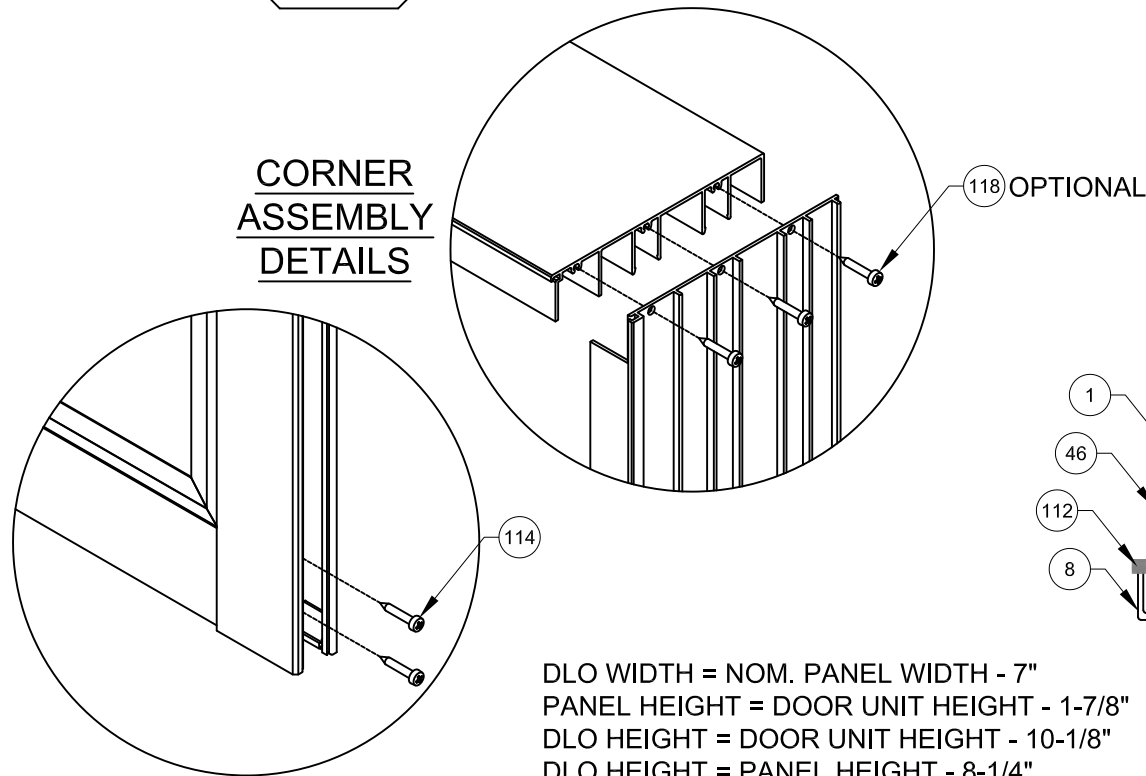
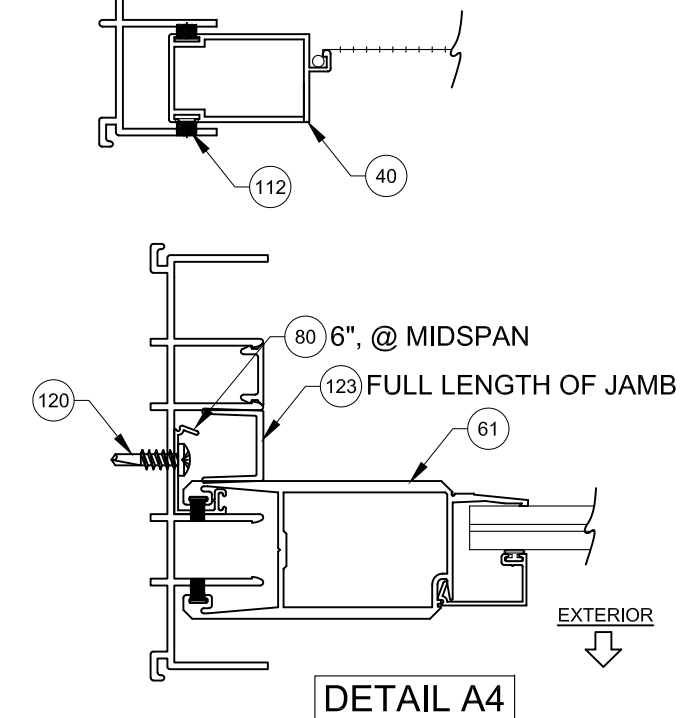
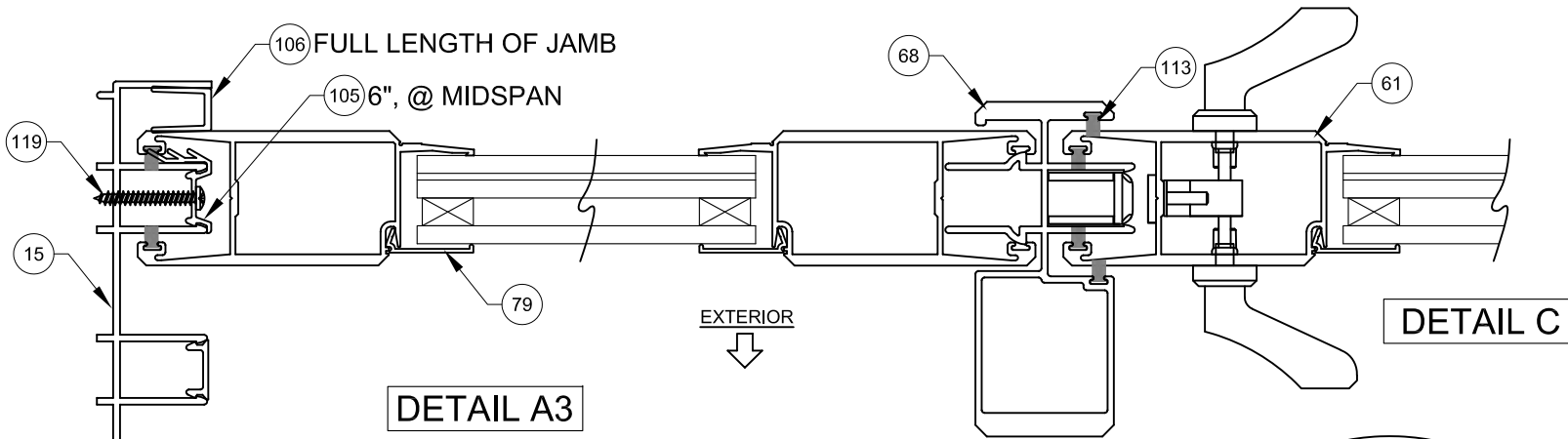
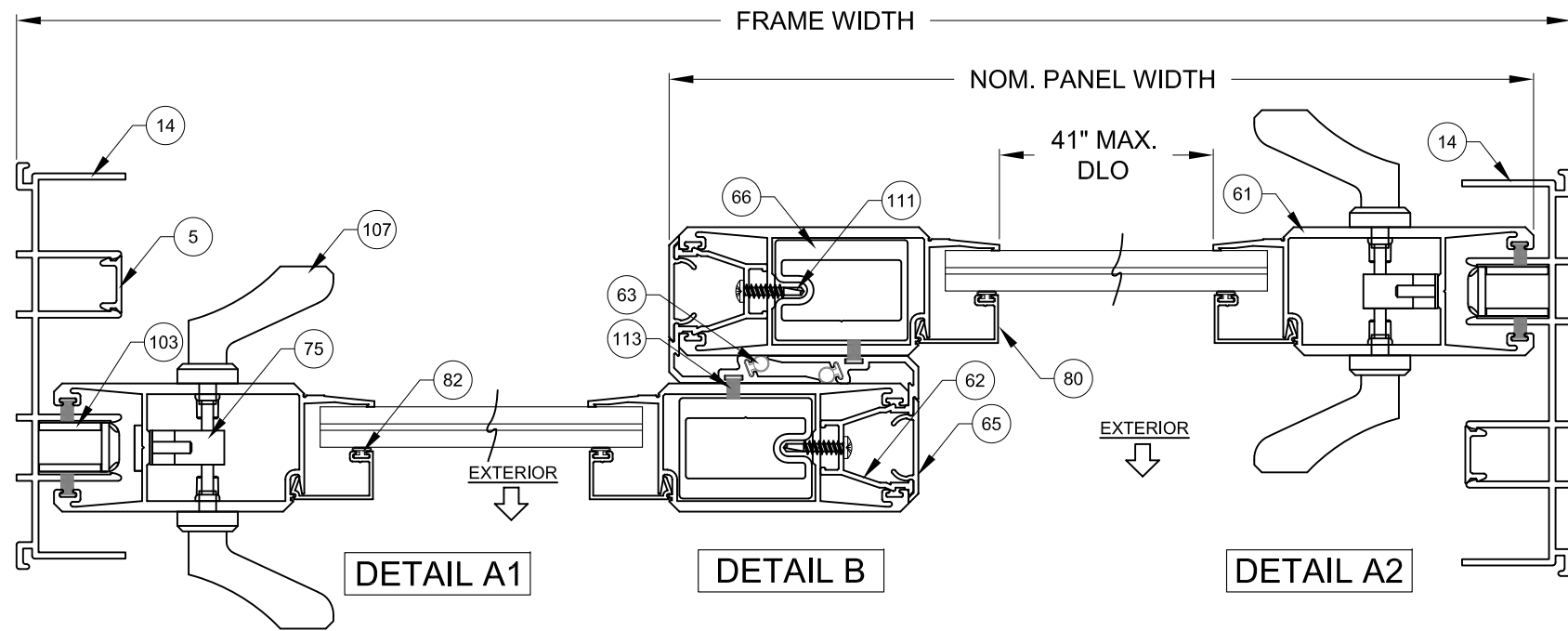

PRODUCT RENEWED
 as complying with the Florida Building Code
 NOA-No. 25-0102.02
 Expiration Date 03/24/2030
 By *Ishag I. Chank*
 Miami-Dade Product Control

Revision:
 Revised Co. Address
 JR - 12/20/24

PREPARED BY A. LYNN MILLER 1070 TECHNOLOGY DRIVE N. VENICE, FL 34275 (941) 480-1600	REGISTRATION #29296	Date	03/21/20
		Drawn By	JENS ROSOWSKI
PGT Custom Windows and Doors 3400 PRECISION DRIVE N. VENICE, FL 34275 (941) 480-1600	ALUMINUM SLIDING GLASS DOOR (SM)	No.	8 OF 10
		Sheet	SGD770 HP
ASSEMBLY CROSS SECTIONS		DWG	PGT0005
		Rev.	J

PGT
 Custom Windows and Doors
 3400 PRECISION DRIVE
 N. VENICE, FL 34275
 (941) 480-1600

ANTHONY LYNN MILLER
 LICENSE
 No. 58705
A. Lynn Miller
 12/20/24
 STATE OF FLORIDA
 PROFESSIONAL ENGINEER
 A. LYNN MILLER, P.E.
 P.E.# 58705

TABLE 2:

ITEM	PGT. #	Description	Material
1	617306	2-TRACK HEAD	6063-T6 ALUM.
2	617303	2-TRACK HEAD WITH SCREEN RAIL	6063-T6 ALUM.
5	617314	FRAME SCREW COVER	6063-T6 ALUM.
7	617304	2-TRACK SILL	6063-T6 ALUM.
8	617301	2-TRACK SILL WITH SCREEN RAIL	6063-T6 ALUM.
11	617313	FRAME SILL TRACK INSERT	6063-T6 ALUM.
14	617305	2-TRACK JAMB	6063-T6 ALUM.
15	617302	2-TRACK JAMB WITH SCREEN RAIL	6063-T6 ALUM.
18	617322	SILL RISER, FLAT, 1-1/2"	6063-T6 ALUM.
19	617319	SILL RISER, BOX, 1-1/2"	6063-T6 ALUM.
20	617321	SILL RISER, FLAT, 2-1/2"	6063-T6 ALUM.
21	617318	SILL RISER, BOX, 2-1/2"	6063-T6 ALUM.
22	617355	SILL RISER, FLAT, 3-1/4"	6063-T6 ALUM.
23	617354	SILL RISER, BOX, 3-1/4"	6063-T6 ALUM.
24	617320	SILL RISER, FLAT, 4"	6063-T6 ALUM.
25	617323	SILL RISER, BOX, 4"	6063-T6 ALUM.
40	612258	SCREEN SIDE RAIL - LOCKSTILE	6063-T6 ALUM.
41	7LOCKWGSK	SCREEN LOCKSET	
42	41818	SCREEN KEEPER SPACER SET	
45	612256	SCREEN TOP RAIL	6063-T6 ALUM.
46	612257	SCREEN BOTTOM RAIL	6063-T6 ALUM.
47	7SRAZ	STANDARD ROLLER	
48	7SRAX	STANDARD ROLLER - ST. STL.	STAINLESS STEEL
51	61692	SCREEN SPLINE - .165	
53	61816C20	SCREEN CLOTH	
54		1/2" x 4" x 1/16" SETTING BLOCK	NEOPRENE
55		1" X 4" X 1/16" SETTING BLOCK	NEOPRENE
61	617326	PANEL STILE (HEAVY DUTY)	6063-T6 ALUM.
62	617327	INTERLOCK ADAPTOR	6063-T6 ALUM.
63	6TP248	VINYL BULB WSTP. - THIN (INSIDE INTERLOCK)	
64	71729	SILL END WEATHERSTRIP PAD	
65	617328	INTERLOCK SCREW COVER	6063-T6 ALUM.
66	617346	INTERLOCK ALUM REINFORCEMENT	6063-T6 ALUM.
68	617339	HEAVY DUTY ASTRAGAL	6063-T6 ALUM.
69	617324	TOP & BOTTOM RAIL	6063-T6 ALUM.
70	417350	WEATHERSTRIP EXTENSION (INJECTION MOLDED)	
71	71695	1-1/2" X 1" X 3/4" HIGH FIN SEAL DUST PLUGS	
72	78153X	TANDEM ROLLER ASSY.	STAINLESS STEEL
73	78153N	TANDEM ROLLER ASSY.	NYLON
74	SILICONE	DOW 791, 899, 983, 995 OR GE 7700	
75	78185X	GEMINI MORTICE 3-PLY LOCK W/LONG TRIM PLATE	
76	71032X1FPFX	#10-32 X 1" FH SCREW W/ TYPE "F" TIP	STAINLESS STEEL
77	7103239	10-32 STEEL U-NUT	ZINC
79	617357	1" IG BEAD	6063-T6 ALUM.
80	617359	FIXED PANEL CLIP	6063-T6 ALUM.

ITEM	PGT. #	Description	Material
82	6TP247K	VINYL BULB WEATHERSTRIP	
83	IGTAPE	1/2" X 1/16" SINGLE SIDE ADHESIVE TAPE	
100	48052	ROLLER ADJ. HOLE PLUG	
101	72087	JAMB BUMPER	
102	71696	DUST PLUG	PVC
103	78186X	1" KEEPER	
104	7SDKEEP	SCREEN LOCK KEEPER	
105	617344	FIXED PANEL CLIP - 6" LONG	6063-T6 ALUM.
106	617352	EXTERIOR FIXED PANEL RETAINER	6063-T6 ALUM.
107	varies	HANDLE KIT	
111	710X34PPSDAX	#10 X 3/4" PH. PN. TEK	STAINLESS STEEL
112	67S16	WSTP, 0.270" X 0.170" FIN SEAL	
113	64066	WSTP, 0.187" X .230 FINSEAL	
114	710X115PPX	#10 X 1-1/2" SMS	STAINLESS STEEL
115	710XPPT	#10 X 1" SMS	STAINLESS STEEL
116	720X1X	#14-20 X 1" MS	STAINLESS STEEL
117	720X112X	#14-20 X 1-1/2" MS	STAINLESS STEEL
118		#8 X 1" SMS	STAINLESS STEEL
119		#8 X 1-1/4" SMS	STAINLESS STEEL
120		#10 X 1" SMS	STAINLESS STEEL

ITEMS # 3, 4, 6, 9, 10, 12, 13, 16, 17, 26-39, 43, 44, 49, 50, 52, 56-60, 67, 81, 78, 84-99 & 108-110 ARE NOT USED AND ARE NOT PART OF THIS APPROVAL.

TABLE 3:

Material	Min. F _y	Min. F _u
#12 Steel Screw	92 ksi	120 ksi
#12 18-8 Screw	60 ksi	95 ksi
#12 410 Screw	90 ksi	110 ksi
1/4" DeWalt/Elco Aggre-Gator®	57 ksi	96 ksi
1/4" DeWalt UltraCon+®	148 ksi	164 ksi
1/4" 410 SS DeWalt/Elco CreteFlex®	127.4 ksi	189.7 ksi
6063-T5 Aluminum	16 ksi	22 ksi
A36 Steel	36 ksi	58 ksi
Gr. 33 Steel Stud	33 ksi	45 ksi

PRODUCT RENEWED
as complying with the Florida
Building Code
NOA-No. 25-0102.02
Expiration Date 03/24/2030
By Ishag I. Chank
Miami-Dade Product Control

REVISION: REVISED CO. ADDRESS
JR - 12/20/24

PREPARED BY A. LYNN MILLER 1070 TECHNOLOGY DRIVE N. VENICE, FL 34275 (941) 480-1600	REGISTRATION #29296	Date	03/21/20
		Drawn By	JENS ROSOWSKI
		No.	PGT0005
		Sheet	9 OF 10
CUSTOM WINDOWS AND DOORS 3400 PRECISION DRIVE N. VENICE, FL 34275 (941) 480-1600		ALUMINUM SLIDING GLASS DOOR (SM)	
		BOM SGD770 HP	

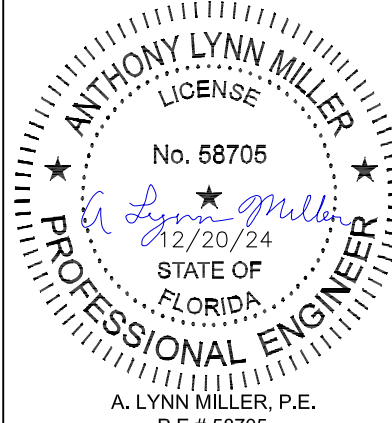

 ANTHONY LYNN MILLER
 LICENSE
 No. 58705
 12/20/24
 STATE OF
 FLORIDA
 PROFESSIONAL ENGINEER
 A. LYNN MILLER, P.E.
 P.E.# 58705

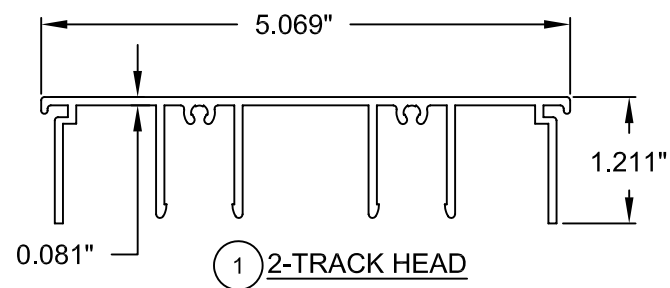

① 2-TRACK HEAD

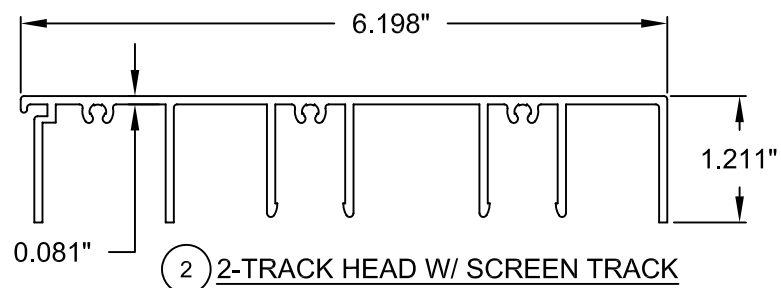

② 2-TRACK HEAD W/ SCREEN TRACK

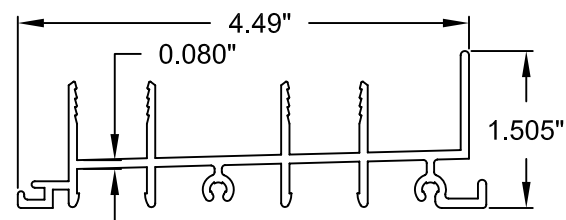

⑦ 2-TRACK SILL

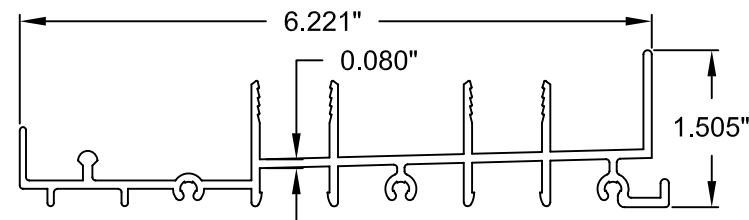

⑧ 2-TRACK SILL W/ SCREEN TRACK

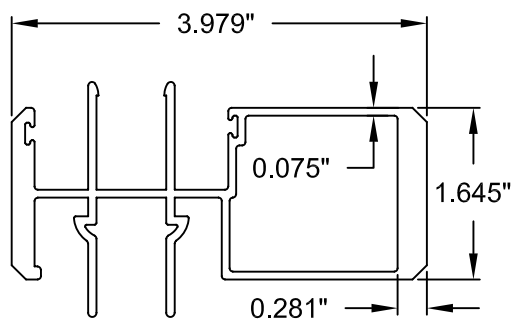

⑥⑧ HEAVY DUTY ASTRAGAL

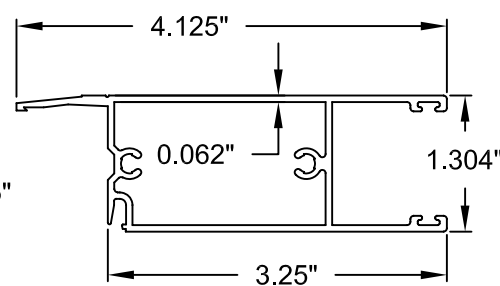

⑥⑨ TOP/BOTTOM RAIL

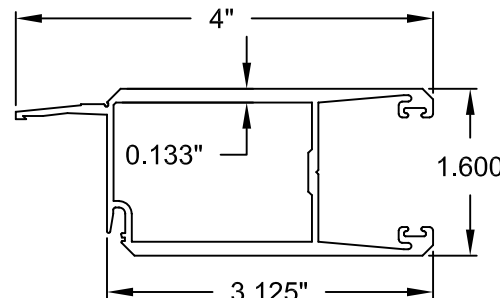

⑥① HEAVY DUTY STILE

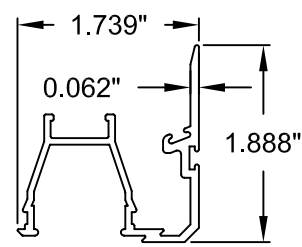

⑥② INTERLOCK ADAPTER

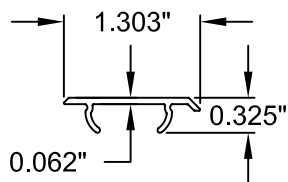

⑥⑤ INTERLOCK SCREW COVER

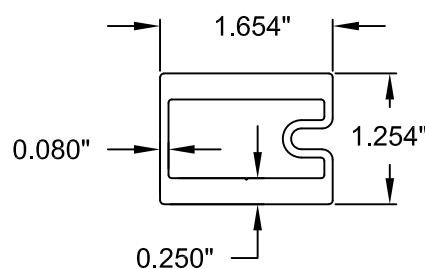

⑥⑥ REINFORCEMENT

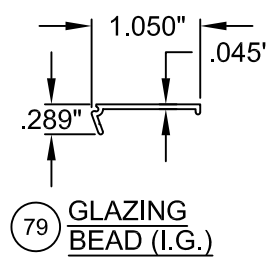

⑦⑨ GLAZING BEAD (I.G.)

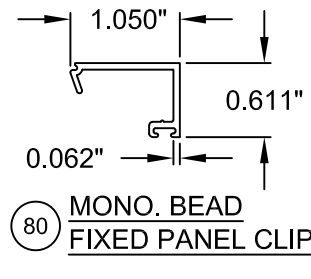

⑧① MONO. BEAD FIXED PANEL CLIP

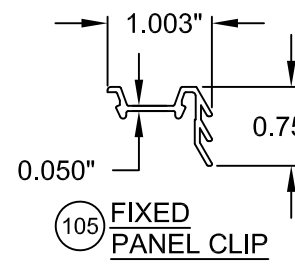

⑩⑤ FIXED PANEL CLIP

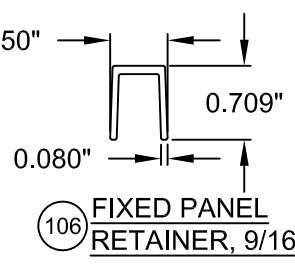

⑩⑥ FIXED PANEL RETAINER, 9/16"

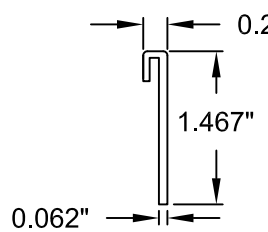

⑱* SILL RISER, FLAT, 1-1/2"*

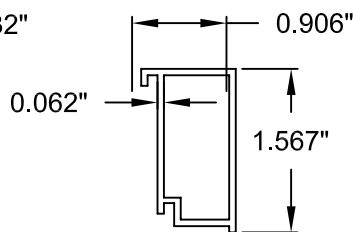

⑲* SILL RISER, BOX, 1-1/2"*

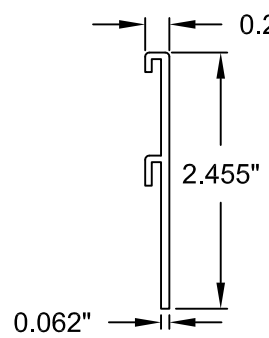

⑳ SILL RISER, FLAT, 2-1/2"

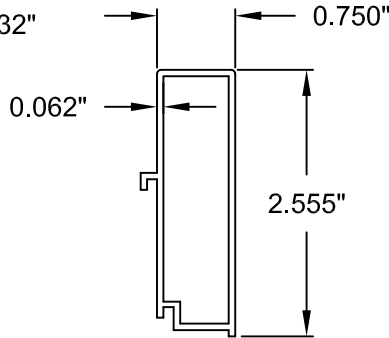

㉑ SILL RISER, BOX, 2-1/2"

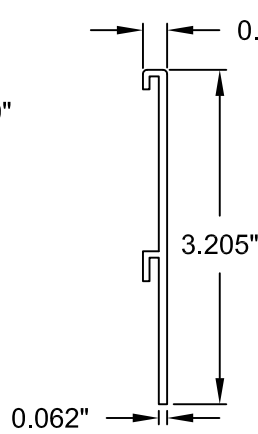

㉒ SILL RISER, FLAT, 3-1/4"

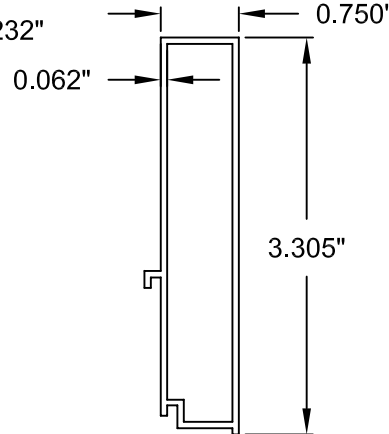

㉓ SILL RISER, BOX, 3-1/4"

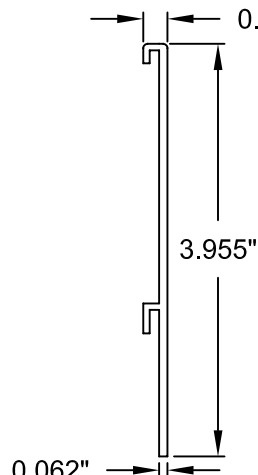

㉔ SILL RISER, FLAT, 4"

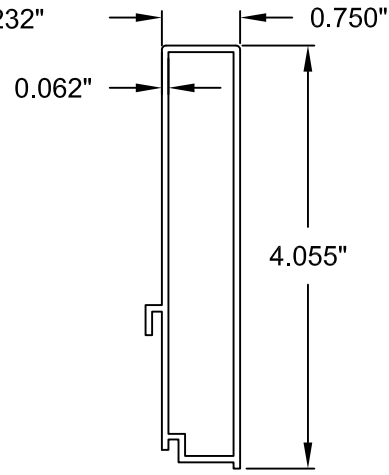

㉕ SILL RISER, BOX, 4"

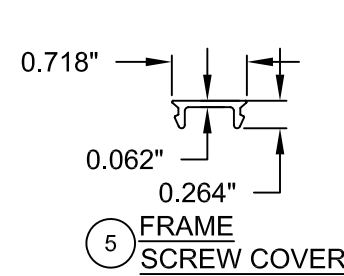

⑤ FRAME SCREW COVER

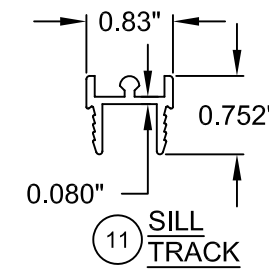

⑪ SILL TRACK

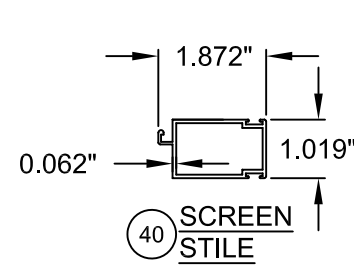

④⑩ SCREEN STILE

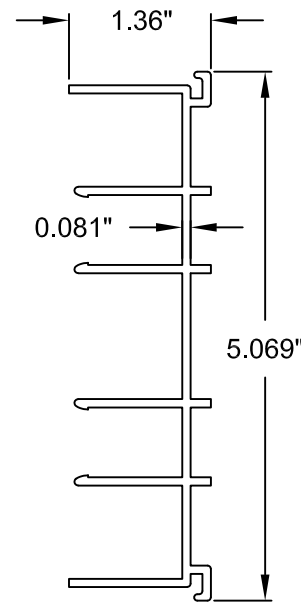

⑭ 2-TRACK JAMB

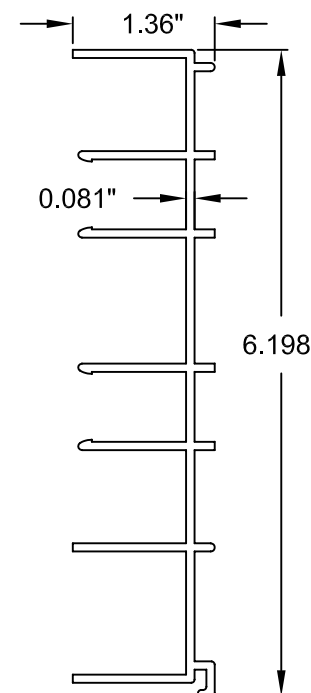

⑮ 2-TRACK JAMB W/ SCREEN TRACK

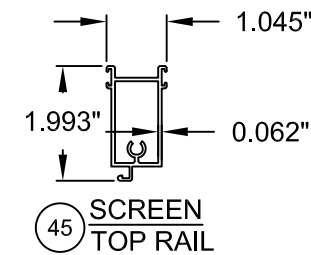

④⑤ SCREEN TOP RAIL

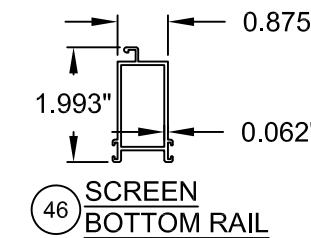

④⑥ SCREEN BOTTOM RAIL

PRODUCT RENEWED
 as complying with the Florida Building Code
 NOA-No. 25-0102.02
 Expiration Date 03/24/2030
 By *Ishag I. Chank*
 Miami-Dade Product Control

Revised: _____
 REVISED CO. ADDRESS
 JR - 12/20/24

PREPARED BY A. LYNN MILLER 1070 TECHNOLOGY DRIVE N. VENICE, FL 34275 (941) 480-1600	REGISTRATION #29296	Date	03/21/20
		By	JENS ROSOWSKI
ALUMINUM SLIDING GLASS DOOR (SM)	EXTRUSIONS	No.	PGT0005
		Sheet	10 OF 10
Custom Windows and Doors 3400 PRECISION DRIVE N. VENICE, FL 34275 (941) 480-1600		Series	SGD770 HP

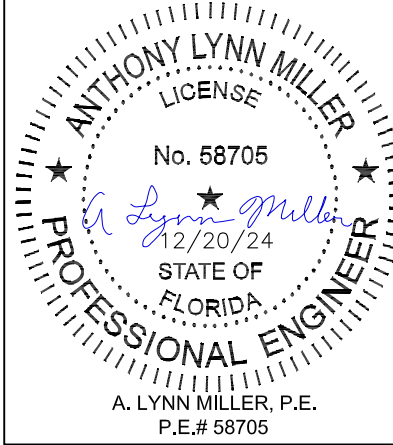

* NOT VALID FOR WATER INFILTRATION RESISTANCE REQUIREMENTS.