



DEPARTMENT OF REGULATORY AND ECONOMIC RESOURCES (RER)
BOARD AND CODE ADMINISTRATION DIVISION

MIAMI-DADE COUNTY
PRODUCT CONTROL SECTION
11805 SW 26 Street, Room 208
Miami, Florida 33175-2474
T (786) 315-2590 F (786) 315-2599
www.miamidade.gov/economy

NOTICE OF ACCEPTANCE (NOA)

O'Hagin Manufacturing, LLC
210 Classic Court, Suite #100
Rohnert Park, CA 94928

SCOPE:

This NOA is being issued under the applicable rules and regulations governing the use of construction materials. The documentation submitted has been reviewed and accepted by Miami-Dade County RER - Product Control Section to be used in Miami Dade County and other areas where allowed by the Authority Having Jurisdiction (AHJ).

This NOA shall not be valid after the expiration date stated below. The Miami-Dade County Product Control Section (In Miami Dade County) and/or the AHJ (in areas other than Miami Dade County) reserve the right to have this product or material tested for quality assurance purposes. If this product or material fails to perform in the accepted manner, the manufacturer will incur the expense of such testing and the AHJ may immediately revoke, modify, or suspend the use of such product or material within their jurisdiction. RER reserves the right to revoke this acceptance, if it is determined by Miami-Dade County Product Control Section that this product or material fails to meet the requirements of the applicable building code.

This product is approved as described herein, and has been designed to comply with the Florida Building Code including the High Velocity Hurricane Zone of the Florida Building Code.

DESCRIPTION: Flame and Ember Resistant Off-Ridge Attic Vent for Clay and Concrete Tile

LABELING: Each unit shall bear a permanent label with the manufacturer's name or logo, city, state and following statement: "Miami-Dade County Product Control Approved", unless otherwise noted herein.

RENEWAL of this NOA shall be considered after a renewal application has been filed and there has been no change in the applicable building code negatively affecting the performance of this product.

TERMINATION of this NOA will occur after the expiration date or if there has been a revision or change in the materials, use, and/or manufacture of the product or process. Misuse of this NOA as an endorsement of any product, for sales, advertising or any other purposes shall automatically terminate this NOA. Failure to comply with any section of this NOA shall be cause for termination and removal of NOA.

ADVERTISEMENT: The NOA number preceded by the words Miami-Dade County, Florida, and followed by the expiration date may be displayed in advertising literature. If any portion of the NOA is displayed, then it shall be done in its entirety.

INSPECTION: A copy of this entire NOA shall be provided to the user by the manufacturer or its distributors and shall be available for inspection at the job site at the request of the Building Official.

This NOA renews NOA# 19-0904.04 and consists of pages 1 through 8.
The submitted documentation was reviewed by Alex Tigera.

10/17/24



NOA No: 24-0220.05
Expiration Date: 11/11/29
Approval Date: 10/17/24
Page 1 of 8

ROOFING ASSEMBLY APPROVAL

Category:	Roofing
Sub-Category:	Ventilation
Materials:	26 ga. G90 Steel; .032" Aluminum; 16 oz. Copper
Minimum Slope:	2:12

TRADE NAMES OF PRODUCTS MANUFACTURED OR LABELED BY APPLICANT

<u>Product</u>	<u>Dimensions</u>	<u>Test Specification</u>	<u>Product Description</u>
Flame and Ember Resistant Off-Ridge Attic Vent S-Profile (High Profile)	Length = 23 ¾" – 26 ¾" Width = 19 ½" – 21 ½" Height = 3 ½" – 4 ½"	TAS 100(A)	Metal roof vent for high 'S' profile interlocking clay or concrete tile roofs.
Flame and Ember Resistant Off-Ridge Attic Vent M-Profile (Medium Profile)	Length = 18"- 26 ¼" Width = 19"- 24 ½" Height = 2"- 4 ½"	TAS 100(A)	Metal roof vent for medium profile interlocking clay or concrete tile roofs.
Flame and Ember Resistant Off-Ridge Attic Vent Flat-Profile (Flat/Low Profile)	Length = 29"- 32" Width = 17 ½" – 19" Height = 1"- 2"	TAS 100(A)	Metal roof vent for flat profile interlocking clay or concrete tile roofs.
Primary Vent	Length = 24" Width = 11" Height = ½" – ¾"	TAS 100(A)	Primary metal vent flashing for S, M, and Flat profile vents, with a galvanized or stainless steel wire mesh.

MANUFACTURING LOCATION

1. Rohnert Park, CA
2. Lakeland, FL

EVIDENCE SUBMITTED

<u>Test Agency/Identifier</u>	<u>Name</u>	<u>Report</u>	<u>Date</u>
PRI Construction Materials Technologies	TAS 100(A)	OHI-014-02-02	12/08/07
	TAS 100(A)	OHI-025-02-01	01/10/08
	TAS 100(A)	OHI-026-02-01	01/10/08
	TAS 100(A)	OHI-029-02-01	05/05/09
	TAS 100(A)	OHI-030-02-02	05/05/09
	TAS 100(A)	OHI-031-02-01	05/05/09
	TAS 100(A)	642T0001	06/21/19
	TAS 100(A)	642T0002	06/21/19
	TAS 100(A)	642T0003	06/21/19
	ASTM B 117	OHI-044-02-01	06/05/18
	ASTM G-155	OHI-043-02-01	06/05/18



NOA No: 24-0220.05
 Expiration Date: 11/11/29
 Approval Date: 10/17/24
 Page 2 of 8

APPROVED APPLICATIONS:

Trade Name: Flame and Ember Resistant Off-Ridge Attic Vent for Clay and Concrete Tile

System Type A: Mechanical attachment of vent under tile.

Slot: Starting approximately 18" down the ridge and a minimum 12" from the edges, mark a 19" x 7" opening centered between layout lines and align approximately as shown on exposure lines as seen in Detail B. Set blade to thickness of sheathing and cut opening. Brush away sawdust and debris.

Installation: Set primary vent over the opening and secure with corrosion resistant 12ga., 1 ¼" galvanized ring shank roofing nails around the vent flange at 4"o.c. Nails shall be of sufficient length to penetrate through the sheathing a minimum of ¾". Seal the primary vent to the underlayment with a Miami Dade approved ASTM D 4586 asphalt roofing cement and Miami Dade approved ASTM D1668 fabric.

Install secondary vent over the primary vent by centering it over the primary vent and bending the wind clip tightly under the preceding course of tile. Each secondary vent will replace 2 field tiles. Secure secondary vent to the roof deck with two (2) corrosion resistant 12ga. 1 ¼" galvanized ring shank roofing nails in the manufacturer's designated locations. Nails shall be of sufficient length to penetrate through the sheathing a minimum of ¾".

Seal the secondary vent to the preceding course of tile with min. ½" bead of an approved Miami Dade ASTM C920 sealant.

Ventilation Calculations: See manufacturer's published literature for net free area.



LIMITATIONS:

1. Refer to applicable Building Code required ventilation.
2. The installation shall be applied in compliance with the manufacturer's current published application instruction and the requirements set forth in the applicable building code.
3. O'Hagin's Flame and Ember Resistant Off-Ridge Attic Vent for Clay and Concrete Tile is approved to be installed over clay or concrete roof tiles only.
4. O'Hagin's Flame and Ember Resistant Off-Ridge Attic Vent for Clay and Concrete Tile shall not be installed on roof heights greater than 40 ft.
5. Do not install vents below or adjacent to valleys or other areas of concentrated water runoff.
6. All products listed herein shall have a quality assurance audit in accordance with the Florida Building Code and Rule 61G20-3 of the Florida Administrative Code.
7. All approved products listed herein shall be labeled and shall bear the imprint or identifiable marking of the manufacturer's name or logo, city and state of manufacturing facility, and the following statement: "Miami-Dade County Product Control Approved" or the Miami-Dade County Product Control Seal as shown below.



DETAIL A PROFILE DRAWINGS

PRIMARY VENT

PRIMARY VENT (SUBFLASHING)

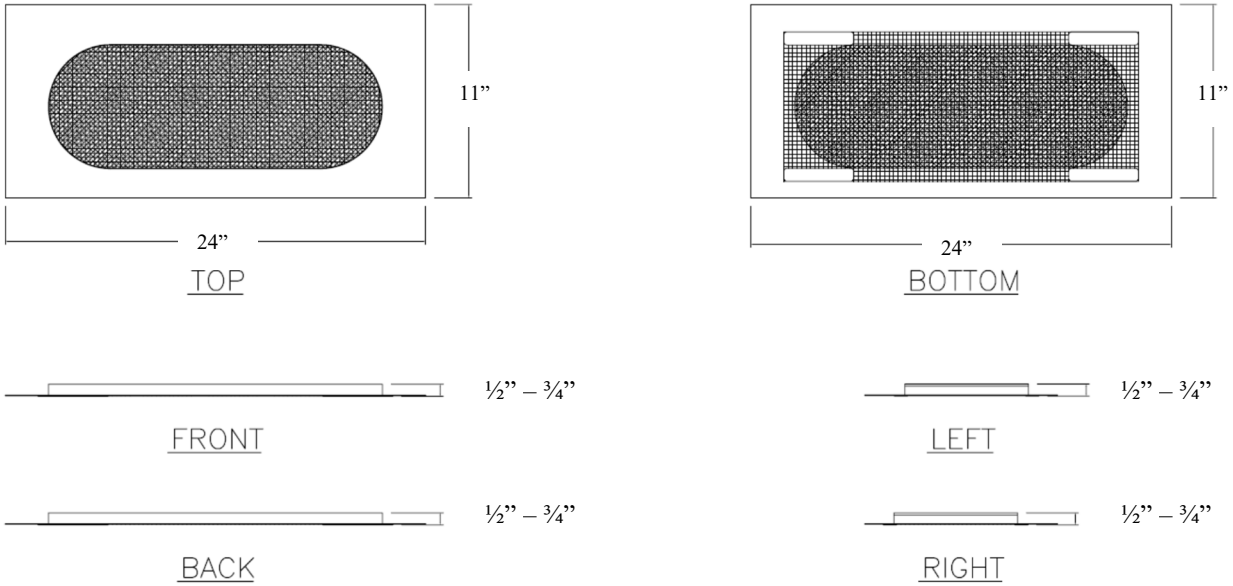

HIGH 'S' PROFILE VENT

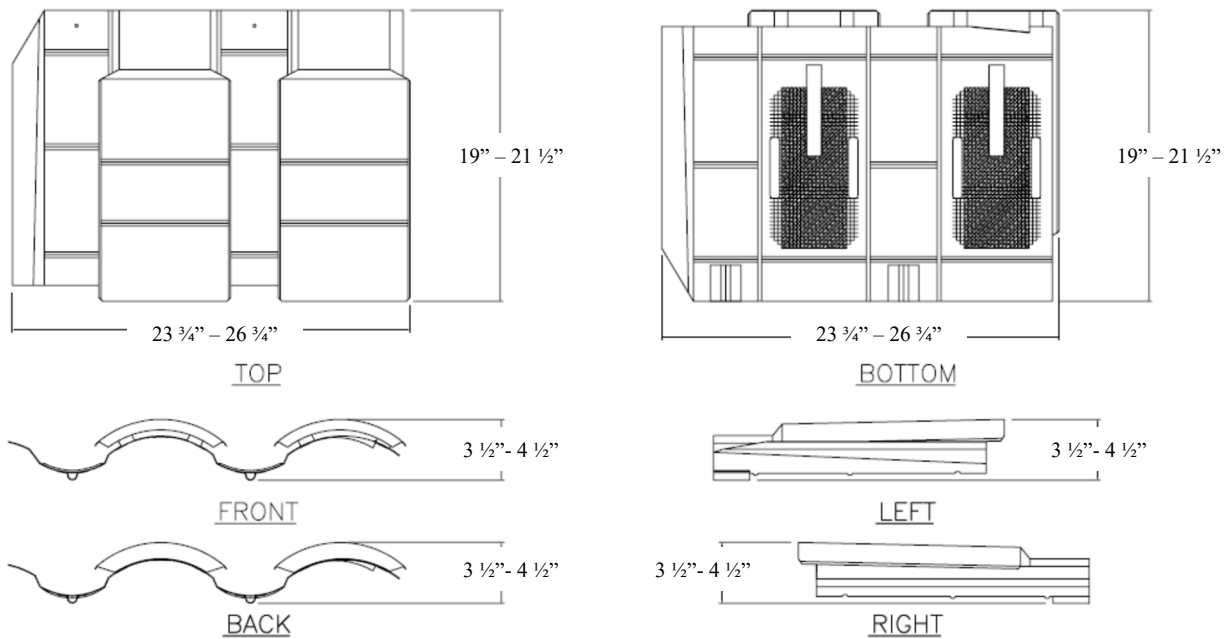

MEDIUM 'M' PROFILE VENT

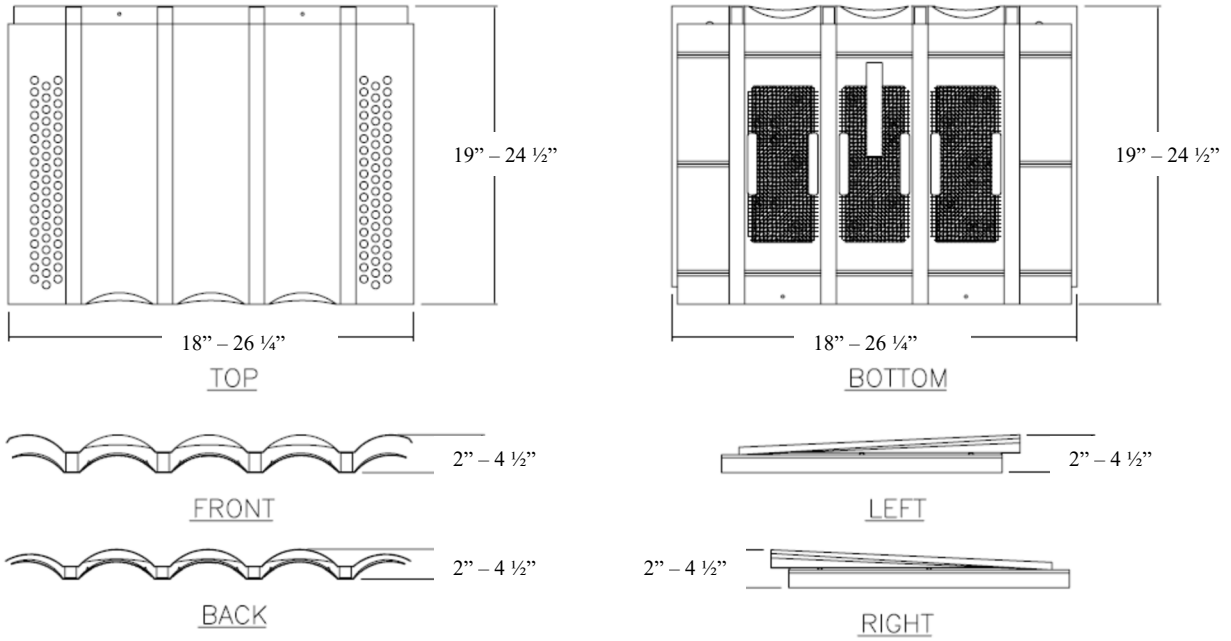

FLAT PROFILE VENT

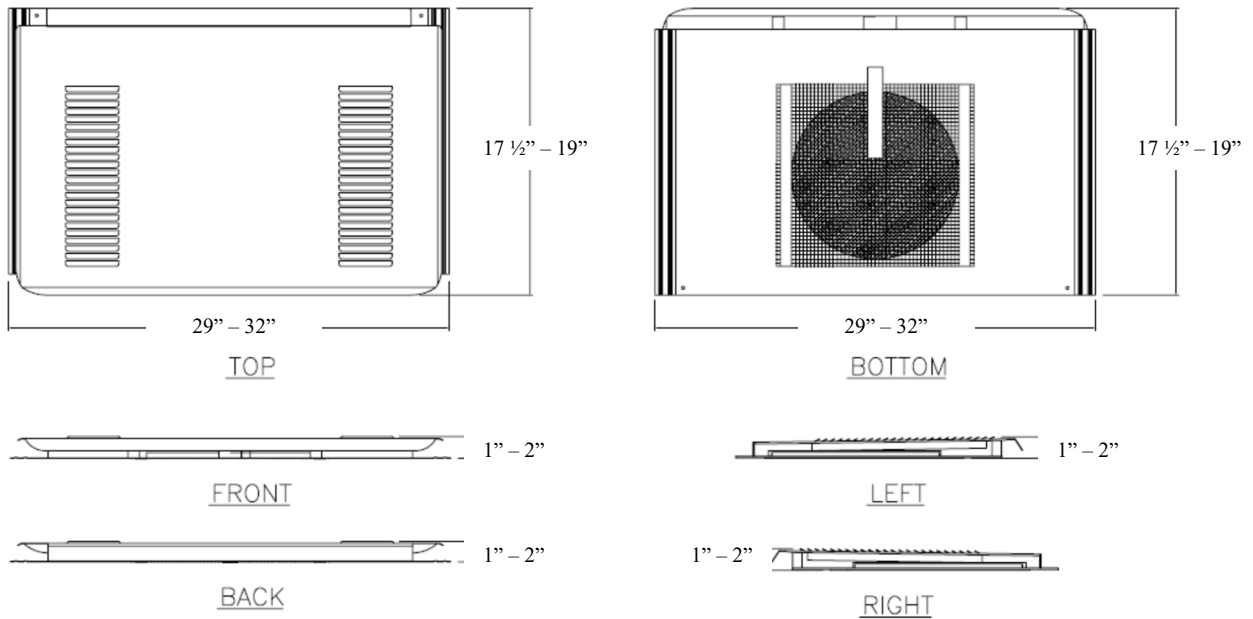

DETAIL B

MODEL 'S' & 'M' PROFILE VENTS FOR 1-PIECE TILES

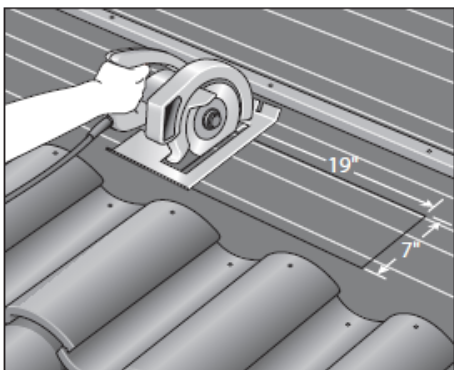

- 1. MARK & CUT** a 19" x 7" hole in the roof deck, centered between layout lines and aligned approximately as shown on the exposure lines. (Note: set blade to the thickness of the sheathing).

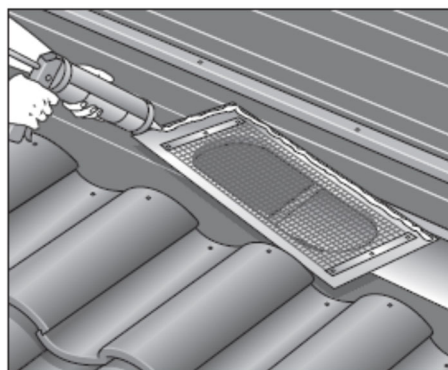

- 2. SEAL** using a Miami Dade approved sealant (Class A where required by code for flame resistance) around outer flange of primary vent.

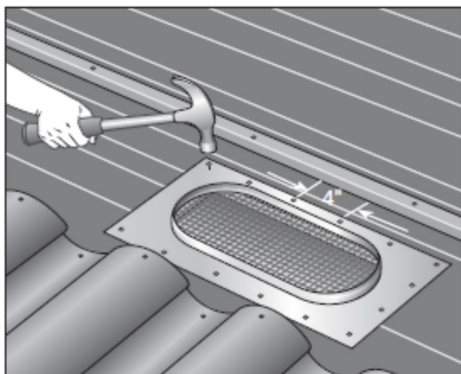

- 3. ATTACH** at 4" o.c. using roofing nails of sufficient length to penetrate the sheathing

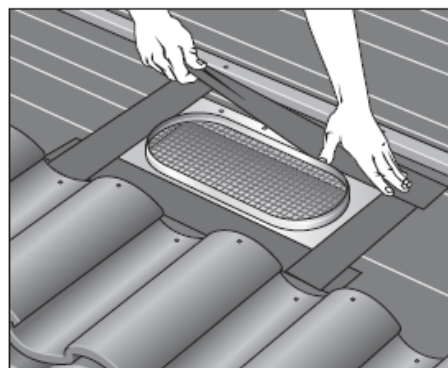

- 4. FLASH.** See general installation notes. When using an approved Miami Dade peel and stick or membrane and mastic methods, apply bottom strip first, then sides and, finally, the top strip.

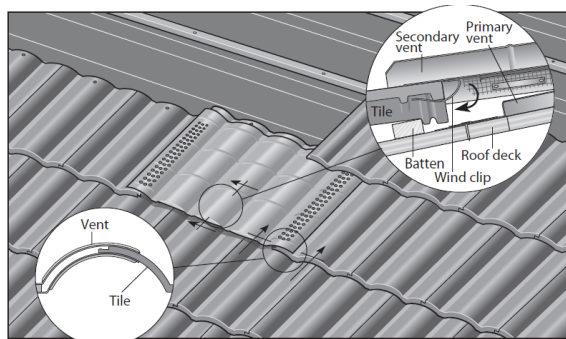

- 5. INSTALL** secondary vent cover. (For "M" style vents only on medium profile tiles, insert tile between perforated top of secondary vent cover and bottom flanged water channel – see inset). *Bend the wind clip tightly under the preceding course of tile, adjusting for head lap.*

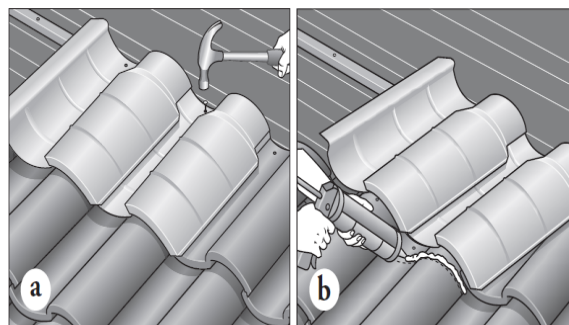

- 6. SECURE** with roofing nails of sufficient length to penetrate sheathing. **SEAL** any gaps between the secondary vent cover and surrounding tiles using a Miami Dade approved sealant (Class A where required by code for flame resistance).



MODEL 'FLAT' PROFILE VENTS FOR FLAT TILES

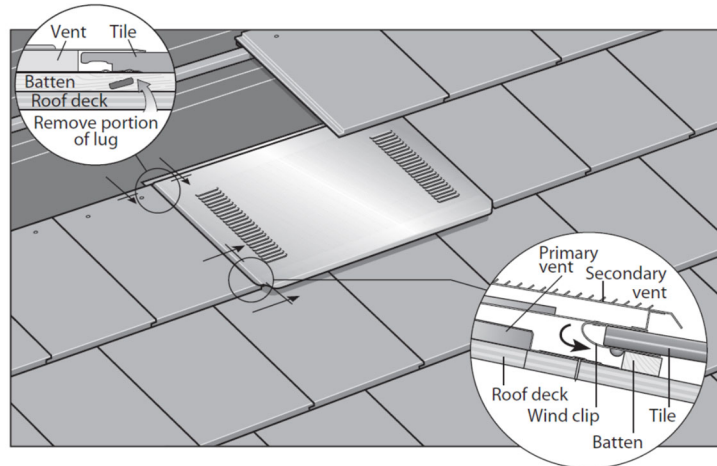

1. Follow steps 1-4 of the 1-piece installation instructions.
2. Tile is inserted between louvered top of secondary vent cover and bottom flange water channel (see inset). *Bend the wind clip tightly under the preceding course of tile, adjusting for head lap.* Remove 2" to 3" of the tile batten lug on either side the secondary vent cover for proper fit. For tiles with continuous lugs, a portion of the lug may be removed as needed for wind clip installation. The secondary vent cover takes place of two field tiles.
3. Secure and seal as shown in Step 6 of the 1-piece installation instructions. Seal the underside of secondary vent and top of tile below with an approved sealant (Class A where required by code for flame resistance).

END OF THIS ACCEPTANCE