



DEPARTMENT OF REGULATORY AND ECONOMIC RESOURCES (RER)  
BOARD AND CODE ADMINISTRATION DIVISION

MIAMI-DADE COUNTY  
PRODUCT CONTROL SECTION

11805 SW 26 Street, Room 208  
Miami, Florida 33175-2474  
T (786) 315-2590 F (786) 315-2599  
[www.miamidade.gov/economy](http://www.miamidade.gov/economy)

**NOTICE OF ACCEPTANCE (NOA)**

**Westlake Royal Roofing LLC**  
7575 Irvine Center Dr. #100,  
Irvine, California 92618

**SCOPE:**

This NOA is being issued under the applicable rules and regulations governing the use of construction materials. The documentation submitted has been reviewed and accepted by Miami-Dade County RER - Product Control Section to be used in Miami-Dade County and other areas where allowed by the Authority Having Jurisdiction (AHJ).

This NOA shall not be valid after the expiration date stated below. The Miami-Dade County Product Control Section (in Miami-Dade County) and/or the AHJ (in areas other than Miami-Dade County) reserve the right to have this product or material tested for quality assurance purposes. If this product or material fails to perform in the accepted manner, the manufacturer will incur the expense of such testing and the AHJ may immediately revoke, modify, or suspend the use of such product or material within their jurisdiction. RER reserves the right to revoke this acceptance, if it is determined by Miami-Dade County Product Control Section that this product or material fails to meet the requirements of the applicable building code.

This product is approved as described herein, and has been designed to comply with the Florida Building Code including the High Velocity Hurricane Zone of the Florida Building Code.

**DESCRIPTION: PINE-CREST Shake, PACIFIC Tile, BARREL-VAULT Tile, COTTAGE Shingle, and GRANITE-RIDGE Shingle Steel Stone Coated Roofing Products**

**LABELING:** Each unit shall bear a permanent label with the manufacturer's name or logo, city, state and following statement: "Miami-Dade County Product Control Approved", unless otherwise noted herein.

**RENEWAL** of this NOA shall be considered after a renewal application has been filed and there has been no change in the applicable building code negatively affecting the performance of this product.

**TERMINATION** of this NOA will occur after the expiration date or if there has been a revision or change in the materials, use, and/or manufacture of the product or process. Misuse of this NOA as an endorsement of any product, for sales, advertising or any other purposes shall automatically terminate this NOA. Failure to comply with any section of this NOA shall be cause for termination and removal of NOA.

**ADVERTISEMENT:** The NOA number preceded by the words Miami-Dade County, Florida, and followed by the expiration date may be displayed in advertising literature. If any portion of the NOA is displayed, then it shall be done in its entirety.

**INSPECTION:** A copy of this entire NOA shall be provided to the user by the manufacturer or its distributors and shall be available for inspection at the job site at the request of the Building Official.

This NOA renews NOA # 22-0331.16 and consists of pages 1 through 13.  
The submitted documentation was reviewed by Alex Tigera.

05/02/24



NOA No.: 24-0318.01  
Expiration Date: 05/09/29  
Approval Date: 05/02/24  
Page 1 of 13

## ROOFING ASSEMBLY APPROVAL:

<b>Category:</b>	Roofing
<b>Sub-Category:</b>	Non-Structural Metal Roofing
<b>Material:</b>	Steel
<b>Deck Type:</b>	Wood
<b>Maximum Design Pressure</b>	See specific profile below.

## TRADE NAMES OF PRODUCTS MANUFACTURED OR LABELED BY APPLICANT:

<u>Product</u>	<u>Dimensions</u>	<u>Test Specifications</u>	<u>Product Description</u>
COTTAGE Shingle	L = 51" W = 14" T= min. 26ga. yield strength 44.2-ksi	TAS 110	Corrosion resistant, galvalume, preformed, stone coated, prefinished, metal panels.
PINE-CREST Shake	L = 52" W = 16" T= min. 26ga. yield strength 44.2-ksi	TAS 110	Corrosion resistant, galvalume, preformed, stone coated, prefinished, metal panels.
PACIFIC Tile	L = 52" W = 16" T= min. 26ga. yield strength 44.2-ksi	TAS 110	Corrosion resistant, galvalume, preformed, stone coated, prefinished, metal panels.
BARREL-VAULT Tile	L = 45-1/8" W= 15 5/8" T = min. 26ga. yield strength: 45.6-ksi	TAS 110	Corrosion resistant, galvalume, preformed, stone coated, prefinished, metal panels.
GRANITE-RIDGE Shingle	L = 46 1/16" W= 15 5/8" T = min. 26ga. yield strength: 45.9-ksi	TAS 110	Corrosion resistant, galvalume, preformed, stone coated, prefinished, metal panels.
Trim Pieces	l = varies w = varies T = min. (26-ga.)	TAS 110	Standard flashing and trim pieces. Manufactured for each panel.

## MANUFACTURING LOCATION:

- Oceanside, CA.



**EVIDENCE SUBMITTED:**

<u>Test Agency</u>	<u>Test Identifier</u>	<u>Test Name/Report</u>	<u>Date</u>
PRI Construction Materials Technologies	BORR-007-02-01	TAS 110 /ASTM B 117	08/07/18
	BORR-007-02-01A	ASTM G 155 / TAS 110	08/07/18
	BORR-009-02-01C	TAS 100	03/20/18
	BORR-009-02-01D	TAS 125 / UL 580	03/20/18
	BORR-009-02-01E	TAS 125 / UL 580	03/20/18
	BORR-009-02-01F	ASTM E 8	03/20/18
	BORR-009-02-01G	TAS 100	03/20/18
	GRT-010-02-01	TAS 100	03/16/12
	GRT-015-02-02	TAS 125	03/22/13
	GRT-026-02-01	TAS 125	12/11/15
	GRT-022-02-01	TAS 100	02/27/15



## APPROVED ASSEMBLIES:

<b>System A:</b>	<b>PINE-CREST Shake, PACIFC Tile, BARREL-VAULT Tile, COTTAGE Shingle(WITH BATTENS)</b>
<b>Deck Type:</b>	Wood, Non-Insulated
<b>Deck Description:</b>	New Construction <sup>19</sup> / <sub>32</sub> " or greater plywood or wood plank, <b>or Re-roof 15/32" or greater plywood or wood plank.</b>
<b>Slope Range:</b>	3": 12" or greater
<b>Maximum Uplift Pressure:</b>	<b>-150 (See Below)</b>

---

<b>Deck Attachment:</b>	In accordance with Applicable Building Code, but in no case shall it be less than #8d x 2-1/2" long ring-shank nails spaced <b>6" o.c.</b> In reroofing, where the deck is less than <sup>19</sup> / <sub>32</sub> " thick (minimum <sup>15</sup> / <sub>32</sub> " ), the above attachment method must be in addition to existing attachment.
<b>Underlayment:</b>	Minimum underlayment shall be an ASTM D 226 Type II installed with a minimum 4" side-laps and 6" end-laps. Underlayment shall be fastened with corrosion resistant tin-caps and 1 1/4" annular ring-shank nails, spaced 6" o.c. at all laps and two staggered rows 12" o.c. in the field of the roll. Or, any Miami-Dade County Product Control Approved underlayment having a current NOA.
<b>Fire Barrier Board:</b>	Any approved fire barrier having a current NOA. Refer to a current fire directory listing for fire ratings of this roofing system assembly as well as the location of the fire barrier within the assembly. See Limitation # 1.
<b>Valleys:</b>	Valley construction shall be in compliance with Roofing Application Standard RAS 133 and with Westlake Royal Roofing LLC's current published installation instructions. 2" x 2" wood battens installed under outer flange of valley installed with #8-11x3" bugle head deck screw @16"o.c. #10-14 x2 in HWH with T17 tip fastener on each side of valley metal 18in through metal into batten.
<b>Battens:</b>	Install nominal 2" x 2" SYP wood battens over underlayment at a maximum spacing of 14-1/2" using minimum of one (1) #8-11 x 3" bugle head wood screw at each batten/joist intersection (12"o.c.).
<b>Metal Panels and Accessories:</b>	Install the panel and accessories in compliance with Westlake Royal Roofing LLC's current, published installation instructions and details. Flashing, penetrations, valley construction and other details shall be constructed in compliance with the minimum requirements provided Roofing Application Standards RAS 133.
<b>Field Condition:</b>	Fasten panels through nose of the panel and the vertical leg at the head lap to the battens with #10-16 x 2" HWH wood screws. Use <b>five (5) screws</b> per panel spacing between 8.5" and 12"o.c. through the vertical leg at the head lap beginning at the center of the side lap. See <b>Detail A</b> for fastening patterns.  <b>Maximum Design Pressure: -82.5 psf. (See General Limitation #2)</b>



**Perimeter and Corner  
Condition:**

Fasten panels through nose of the panel and the vertical leg at the head lap to the battens with #10-16 x 2" HWH wood screws. Use **ten (10) screws** per panel spacing between 2 3/4" and 5 3/4" o.c. through the vertical leg at the head lap beginning at the center of the side lap. See **Detail A** for fastening patterns.

*Maximum Design Pressure: -150 psf. (See General Limitation #2)*



<b>System B:</b>	<b>PINE-CREST Shake, PACIFIC Tile, BARREL-VAULT Tile, COTTAGE Shingle (DIRECT DECK)</b>
<b>Deck Type:</b>	Wood, Non-Insulated
<b>Deck Description:</b>	New Construction <sup>19</sup> / <sub>32</sub> " or greater plywood or wood plank or Re-roof <sup>15</sup> / <sub>32</sub> " or greater plywood or wood plank.
<b>Slope Range:</b>	3": 12" or greater
<b>Maximum Uplift Pressure:</b>	<b>-127.5 (See Below)</b>

---

<b>Deck Attachment:</b>	In accordance with Applicable Building Code, but in no case shall it be less than #8d x 2-1/2" long ring-shank nails spaced <b>6" o.c.</b> In reroofing, where the deck is less than <sup>19</sup> / <sub>32</sub> " thick (minimum <sup>15</sup> / <sub>32</sub> " ), the above attachment method must be in addition to existing attachment.
<b>Underlayment:</b>	Minimum underlayment shall be an ASTM D 226 Type II installed with a minimum 4" side-laps and 6" end-laps. Underlayment shall be fastened with corrosion resistant tin-caps and 1 1/4" annular ring-shank nails, spaced 6" o.c. at all laps and two staggered rows 12" o.c. in the field of the roll. Or, any Miami-Dade County Product Control Approved underlayment having a current NOA.
<b>Fire Barrier Board:</b>	Any approved fire barrier having a current NOA. Refer to a current fire directory listing for fire ratings of this roofing system assembly as well as the location of the fire barrier within the assembly. See Limitation # 1.
<b>Valleys:</b>	Valley construction shall be in compliance with Roofing Application Standard RAS 133 and with Westlake Royal Roofing LLC's current published installation instructions.
<b>Metal Panels and Accessories:</b>	Install the panel and accessories in compliance with Westlake Royal Roofing LLC's current published installation instructions and details. Flashing, penetrations, valley, rake construction and other details shall be constructed in compliance with the minimum requirements provided Roofing Application Standards RAS 133.
<b>Field Condition:</b>	Fasten the panel with <b>eight (8)</b> #10-16, 2-1/2" long, HWH wood screws. Use <b>four (4)</b> screws spaced approximately 13" o.c. through the vertical leg at the headlap of the panel beginning at the center of the side lap and use <b>four (4)</b> spaced approximately 12-3/8" o.c. through the horizontal leg at the back of each panel beginning at the side lap. See <b>Detail B</b> for fastening patterns. <i>Maximum Design Pressure: -52.5psf. (See General Limitation #2)</i>
<b>Perimeter and Corner Condition:</b>	Fasten the panel with <b>sixteen (16)</b> #10-16, 2-1/2" long, HWH wood screws. Use <b>eight (8)</b> screws spaced approximately 7.5" o.c. through the vertical leg at the headlap of the panel beginning at the center of the side lap and use <b>eight (8)</b> spaced approximately 6-1/4" o.c. through the horizontal leg at the back of each panel beginning at the side lap. See <b>Detail B</b> for fastening patterns. <i>Maximum Design Pressure: -127.5 psf. (See General Limitation #2)</i>



**System C:** **BARREL-VAULT Tile (With Battens) – Higher HVHZ Install Option**  
**Deck Type:** Wood, Non-insulated  
**Deck Description:** New Construction <sup>19</sup>/<sub>32</sub>" or greater plywood or wood plank, or Re-roof <sup>15</sup>/<sub>32</sub>" or greater plywood or wood plank.  
**Slope Range:** 3": 12" or greater  
**Maximum Uplift Pressure:** **-202.5 PSF. (See Below)**

---

**Deck Attachment:** In accordance with applicable Building Code, but in no case shall it be less than 8d x 2 3/8" ring shank nails spaced 6" o.c. In reroofing, where the deck is less than <sup>19</sup>/<sub>32</sub>" thick (Minimum <sup>15</sup>/<sub>32</sub>") The above attachment method must be in addition to existing attachment.

**Underlayment:** Minimum underlayment shall be an ASTM D 226 Type II installed with a minimum 4" side-lap and 6" end-laps. Underlayment shall be fastened with corrosion resistant tin-caps and 12 gauge 1 1/4" annular ring-shank nails, spaced 6" o.c. at all laps and two staggered rows 12" o.c. in the field of the roll or any approved underlayment having a current NOA.

**Fire Barrier Board:** Any approved fire barrier having a current NOA. Refer to a current fire directory listing for fire ratings of this roofing system assembly as well as the location of the fire barrier within the assembly. See Limitation # 1.

**Valleys:** Valley construction shall be in compliance with Roofing Application Standard RAS 133 and with Westlake Royal Roofing LLC's current published installation instructions.

**Battens:** **Field Conditions:** Install nominal 2" x 2" wood battens over underlayment at a maximum spacing of 13-1/2" and oriented perpendicular to the wood joist. Using minimum of one (1) #10 x 3-1/2" bugle head wood screw at each batten/joist intersection (24" o.c.) and one (1) #10 x 3-1/2" bugle head, wood crew spaced 12" o.c. between joists.

**Perimeter and Corner Conditions:** Install nominal 2" x 2" wood battens over underlayment at a maximum spacing of 13-1/2" oriented perpendicular to the wood joist. Using minimum of one (1) #10 x 3-1/2" bugle head wood screw at each batten/joist intersection (24" o.c.) and two (2) #10 x 3-1/2" bugle head, wood crew spaced 8" o.c. between joists.

**Metal Panels and Accessories:** Install the BARREL-VAULT Tile and accessories in compliance with Westlake Royal Roofing LLC's current, published installation instructions and details. Flashings, penetrations, valley construction and other details shall be constructed in compliance with the minimum requirements provided in Roofing Application Standard RAS 133.

**Field Condition:** Fasten panels through the vertical leg of the panel overlap and into the batten with **four (4) #10-15 x 2" HWH** wood screws spaced approximately 11.25" o.c.  
**Maximum Design Pressure: -127.50 psf. (See General Limitation #2)**

**Perimeter and Corner Condition:** Fasten panels through the vertical leg of the panel overlap and into the batten with **eight (8) #10-15 x 2" HWH** wood screws spaced approximately 5.65" o.c.  
**Maximum Design Pressure: -202.5 psf. (See General Limitation #2)**



**System D:** GRANITE-RIDGE Shingle  
**Deck Type:** Wood, Non-insulated  
**Deck Description:** New Construction or Re-roof <sup>19</sup>/<sub>32</sub>" or greater plywood or wood plank or Re-roof <sup>15</sup>/<sub>32</sub>" or greater plywood or wood plank.  
**Slope Range:** 4:12 or greater  
**Maximum Uplift Pressure:** The maximum allowable uplift pressure shall be **-110 psf.**

---

**Deck Attachment:** In accordance with Applicable Building Code, but in no case shall it be less than #8d x 2-1/2" long ring-shank nails spaced **6" o.c.** In reroofing, where the deck is less than <sup>19</sup>/<sub>32</sub>" thick (minimum <sup>15</sup>/<sub>32</sub>" ), the above attachment method must be in addition to existing attachment.

**Underlayment:** Minimum underlayment shall be an ASTM D 226 Type II installed with a minimum 4" side-lap and 6" end-laps. Underlayment shall be fastened with corrosion resistant tin-caps and 12 gauge 1 1/4" annular ring-shanks nails, spaced 6" o.c. at all laps and two staggered rows 12" o.c. in the field of the roll. Or, any approved underlayment having a current NOA.

**Fire Barrier:** Any approved fire barrier having a current NOA. Refer to a current fire directory listing for fire ratings of this roofing system assembly as well as the location of the fire barrier within the assembly. See Limitation # 1.

**Valleys:** Valley construction shall be in compliance with Roofing Application Standard RAS 133 and with Westlake Royal Roofing LLC's current published installation instructions.

**Metal Panels and Accessories:** Install the "Granite Ridge Shingles" and accessories in compliance with Westlake Royal Roofing LLC's current, published installation instructions and details. Flashings, penetrations, valley, rake, eave construction and other details shall be constructed in compliance with the minimum requirements provided in Roofing Application Standard RAS 133.

**Field, Perimeter and Corner Condition:** Panels shall be fastened with **seven (7) #9-15 x 1-1/2" in.** HWH corrosion resistant wood screws along back flange fastening strip of panel spacing maximum 6" o.c. Fasteners shall penetrate through the deck a min. as required by the F.B.C. **(See Detail C).**

***Maximum Design Pressure: -110 psf. (See General Limitation #2)***





## SYSTEM LIMITATIONS

1. Fire classification is not part of this acceptance; refer to a current Approved Roofing Materials Directory for fire ratings of this product.
2. The maximum designed pressure listed herein shall be applicable to all roof pressure zones (i.e. field, perimeters, and corners). Neither rational analysis, nor extrapolation shall be permitted for enhanced fastening at enhanced pressure zones (i.e. perimeters, extended corners and corners).
3. Panels may be rolls formed in continuous lengths from eave to ridge. Maximum lengths shall be as described in Roofing Application Standard RAS 133
4. All panels shall be permanently labeled with the manufacturer's name and/or logo, and the following statement: "Miami-Dade County Product Control Approved" **or** with the Miami-Dade County Product Control Seal as seen below. All clips shall be permanently labeled with the manufacturer's name and/or logo, and/or model.



5. All products listed herein shall have a quality assurance audit in accordance with the Florida Building Code and Rule 61G20-3 of the Florida Administrative Code.



# PROFILE DRAWINGS:

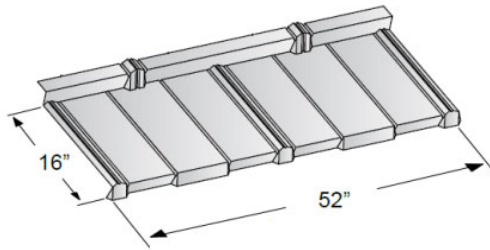

**PINE-CREST SHAKE**

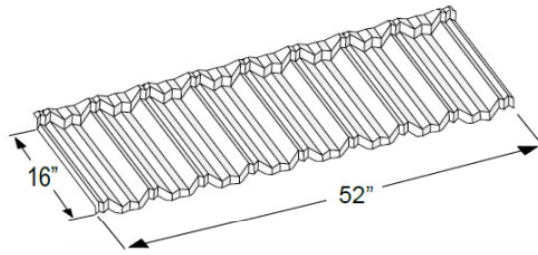

**PACIFIC TILE**

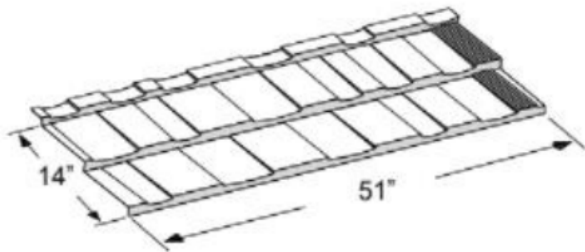

**COTTAGE SHINGLE**

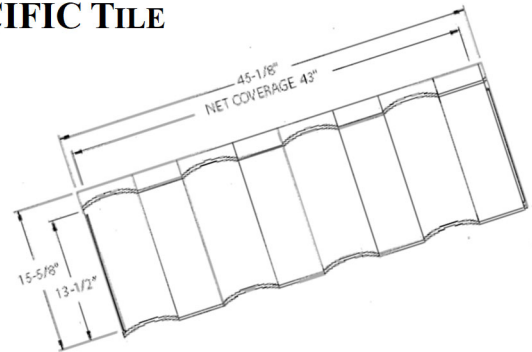

**BARREL-VAULT TILE**

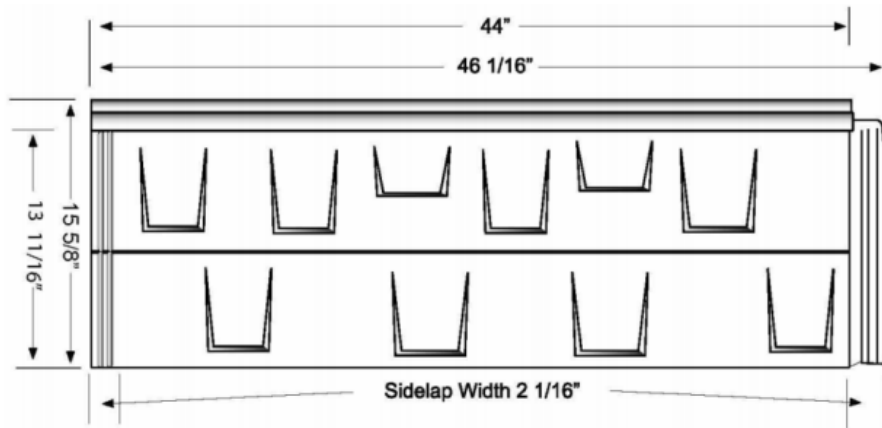

**GRANITE-RIDGE SHINGLE**

**DETAIL A (WITH BATTENS)  
(N.T.S.)**

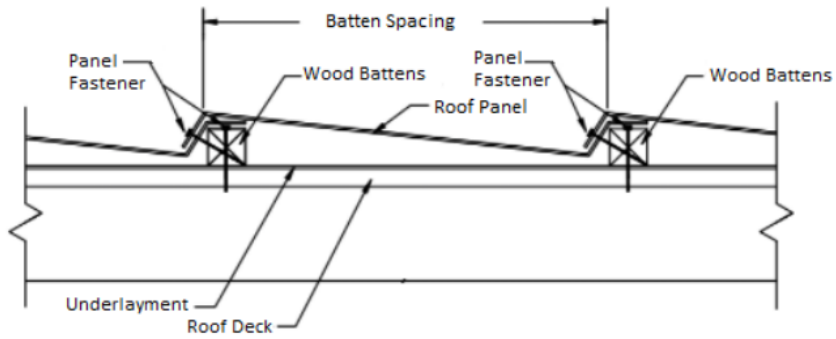

Pine Crest Shake - Batten Pattern 1

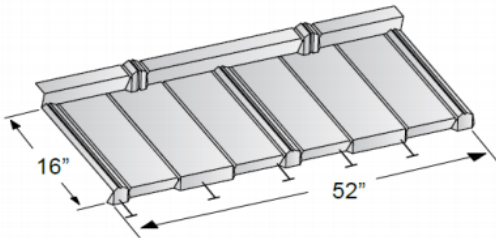

Pine Crest Shake - Batten Pattern 2

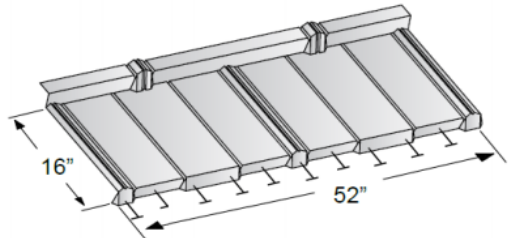

Pacific Tile - Batten Pattern 1

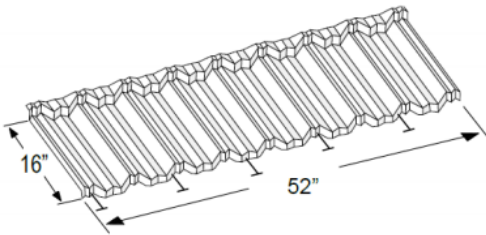

Pacific Tile - Batten Pattern 2

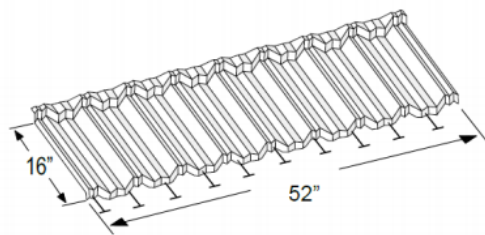

Barrel Vault - Batten Pattern 1

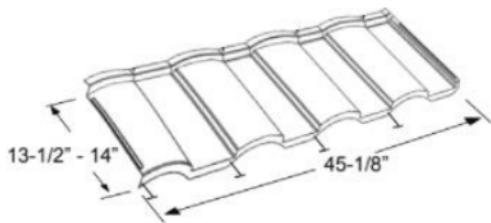

Barrel Vault - Batten Pattern 2

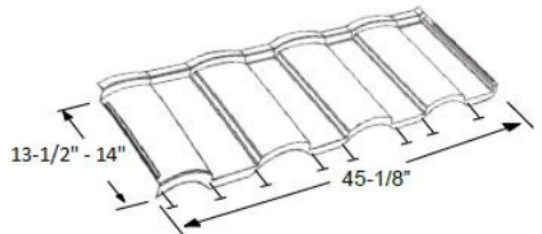

**DETAIL B (DIRECT DECK)  
(N.T.S.)**

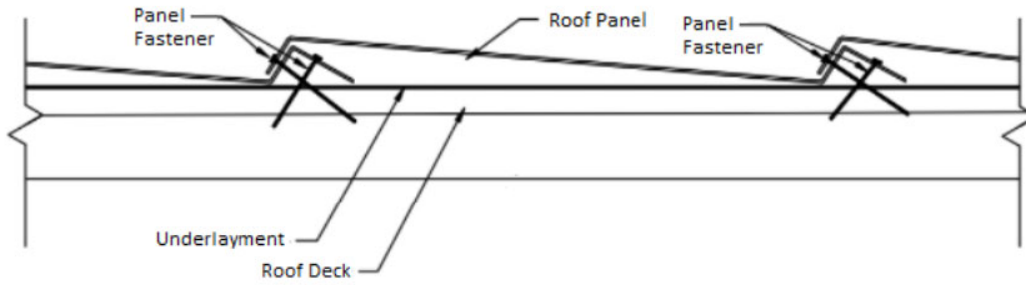

Pine Crest Shake - Direct-to-Deck Pattern 1

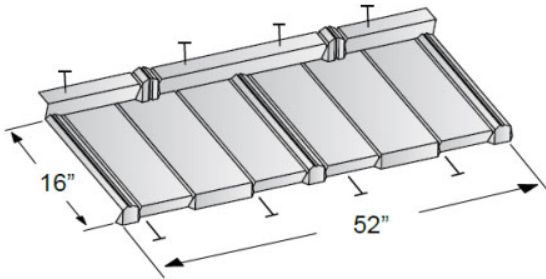

Pine Crest Shake - Direct-to-Deck Pattern 2

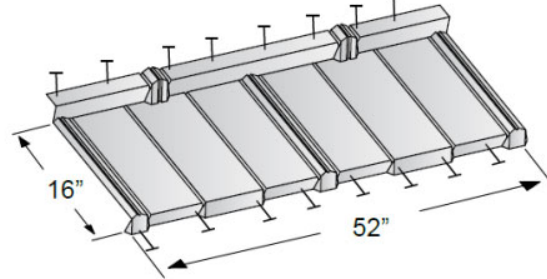

Cottage Shingle - Direct-to-Deck Pattern 1

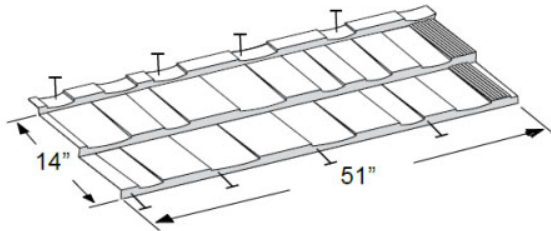

Cottage Shingle - Direct-to-Deck Pattern 2

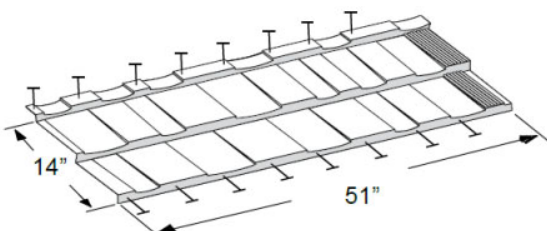

Pacific Tile - Direct-to-Deck Pattern 1

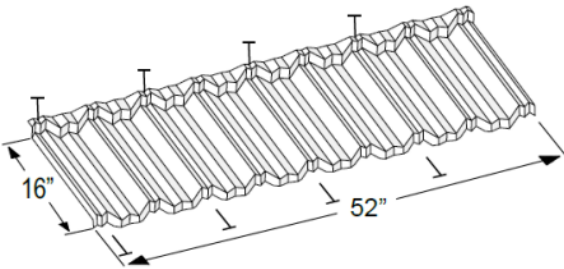

Pacific Tile - Direct-to-Deck Pattern 2

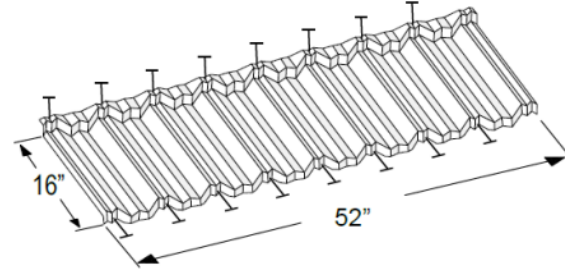

Barrel Vault - Direct-to-Deck Pattern 1

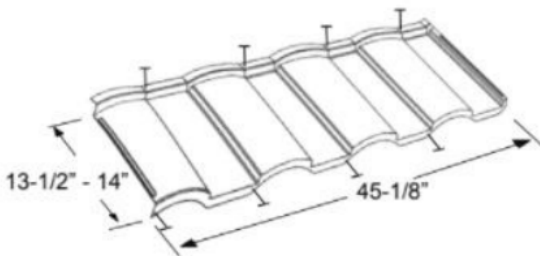

Barrel Vault - Direct-to-Deck Pattern 2

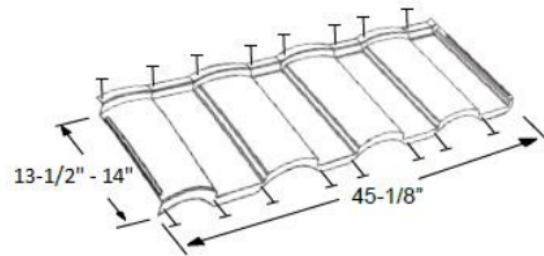

**DETAIL C**

**Granite Ridge Installation Patterns**

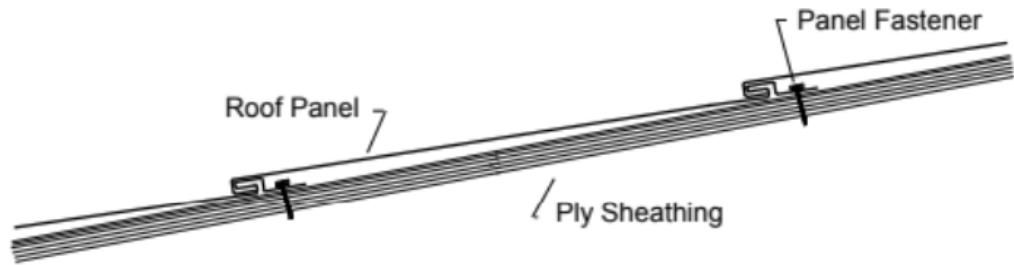

**Granite Ridge - Direct-to-Deck**

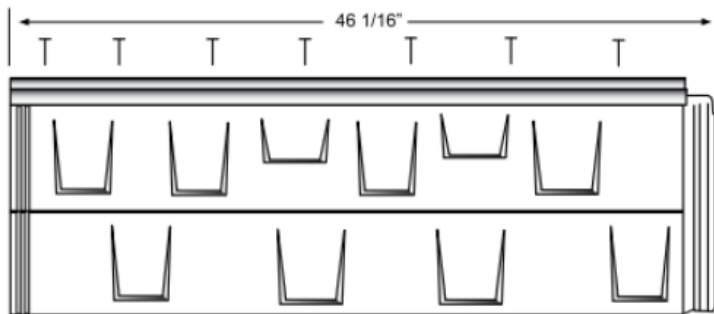

**END OF THIS ACCEPTANCE**

