



DEPARTMENT OF REGULATORY AND ECONOMIC RESOURCES (RER)  
BOARD AND CODE ADMINISTRATION DIVISION

**NOTICE OF ACCEPTANCE (NOA)**

MIAMI-DADE COUNTY  
PRODUCT CONTROL SECTION

11805 SW 26 Street, Room 208  
Miami, Florida 33175-2474  
T (786) 315-2590 F (786) 315-2599

[www.miamidade.gov/economy](http://www.miamidade.gov/economy)

**Major's Metal Roofing & Custom Sheet Metal, Inc.**  
406 NW 54<sup>th</sup> Street  
Miami, FL 33127

**SCOPE:**

This NOA is being issued under the applicable rules and regulations governing the use of construction materials. The documentation submitted has been reviewed and accepted by Miami-Dade County RER - Product Control Section to be used in Miami-Dade County and other areas where allowed by the Authority Having Jurisdiction (AHJ).

This NOA shall not be valid after the expiration date stated below. The Miami-Dade County Product Control Section (in Miami-Dade County) and/or the AHJ (in areas other than Miami-Dade County) reserve the right to have this product or material tested for quality assurance purposes. If this product or material fails to perform in the accepted manner, the manufacturer will incur the expense of such testing and the AHJ may immediately revoke, modify, or suspend the use of such product or material within their jurisdiction. RER reserves the right to revoke this acceptance, if it is determined by Miami-Dade County Product Control Section that this product or material fails to meet the requirements of the applicable building code.

This product is approved as described herein, and has been designed to comply with the Florida Building Code including the High Velocity Hurricane Zone of the Florida Building Code.

**DESCRIPTION: Steel 1.5" Mechanically Seamed Panel**

**LABELING:** Each unit shall bear a permanent label with the manufacturer's name or logo, city, state and following statement: "Miami-Dade County Product Control Approved", unless otherwise noted herein.

**RENEWAL** of this NOA shall be considered after a renewal application has been filed and there has been no change in the applicable building code negatively affecting the performance of this product.

**TERMINATION** of this NOA will occur after the expiration date or if there has been a revision or change in the materials, use, and/or manufacture of the product or process. Misuse of this NOA as an endorsement of any product, for sales, advertising or any other purposes shall automatically terminate this NOA. Failure to comply with any section of this NOA shall be cause for termination and removal of NOA.

**ADVERTISEMENT:** The NOA number preceded by the words Miami-Dade County, Florida, and followed by the expiration date may be displayed in advertising literature. If any portion of the NOA is displayed, then it shall be done in its entirety.

**INSPECTION:** A copy of this entire NOA shall be provided to the user by the manufacturer or its distributors and shall be available for inspection at the job site at the request of the Building Official.

This NOA renews NOA# 23-1023.06 and consists of pages 1 through 9.  
The submitted documentation was reviewed by Alex Tigera.

05/23/24



NOA No.: 24-0402.10  
Expiration Date: 06/17/29  
Approval Date: 05/23/24  
Page 1 of 9

**ROOFING ASSEMBLY APPROVAL:**

**Category:** Roofing  
**Sub-Category:** Non-Structural Metal Roofing  
**Material:** Steel  
**Deck Type:** Wood  
**Maximum Design Pressure:** See Table A, Table B & Table C

**TRADE NAMES OF PRODUCTS MANUFACTURED OR LABELED BY APPLICANT:**

<u>Product</u>	<u>Dimensions</u>	<u>Test Specifications</u>	<u>Product Description</u>
Steel 1.5" Mechanically Seamed Panel	Length: varies Coverage width : 12", 16" & 20" Height: 1.5" min. 24 gage (0.0239") Min Yield Strength: 26 KSI	TAS 125	Corrosion resistant galvanized or galvalume preformed, coated, prefinished, metal panels.
Panel Clip	Length = 2" Width = 3/4" Height = 1.5" min. 24 gage (0.0239")	TAS 110	ASTM Grade 50 preformed, galvalume steel clips with two preformed holes.
Stainless Steel Panel Clip	Length = 2" Width = 3/4" Height = 1.5" min. 24 gage (0.0239")	TAS 110	Grade C preformed, stainless steel clips with two preformed holes.

**TRADE NAMES OF PRODUCTS MANUFACTURED BY OTHERS**

<u>Product</u>	<u>Dimensions</u>	<u>Product Description</u>	<u>Manufacturer</u>
Fasteners	#10	Corrosion resistant steel screws for fastening of clip.	Generic
Titebond WeatherMaster Metal Roof Sealant	Various	Premium-grade, Superior Polymer elastomeric sealant.	Franklin International

**MANUFACTURING LOCATION:**

1. Miami, FL
2. Jobsite roll former machine: # 011707
3. Jobsite roll former machine: # 081901
4. Jobsite roll former machine: # 052102



**EVIDENCE SUBMITTED:**

<u>Test Agency</u>	<u>Test Identifier</u>	<u>Test Name/Report</u>	<u>Date</u>
PRI Construction Materials Technologies	VLS-015-02-01 VLS-015-02-01	ASTM G 23 ASTM B 117	05/15/18 05/15/18
PRI Asphalt Technologies, Inc.	MRI-001-01-01	TAS 100	08/18/03
Hurricane Test Laboratory, Inc.	0299-0801-03 0299-0320.04	TAS 125 TAS 125	10/27/03 03/25/04
Intertek	L3972.04-450-18 R0	TAS 125	01/05/21



**APPROVED ASSEMBLIES:**

**System A:** Steel 1.5" Mechanically Seamed Panel (Maximum 20" coverage width panels)  
**Deck Type:** Wood, Non-insulated  
**Deck Description:** New Construction 1<sup>9</sup>/<sub>32</sub>" or greater plywood or wood plank, or for re-roofing 1<sup>5</sup>/<sub>32</sub>" or greater plywood.  
**Slope Range:** 2": 12" or greater  
**Maximum Uplift Pressure:** See Table A below

**Deck Attachment:** In accordance with applicable Building Code, but in no case it shall be less than 8d annular ring shank nails spaced 6" o.c. in the field and 4" o.c. along the perimeter of the sheet. In reroofing, where the deck is less than 1<sup>9</sup>/<sub>32</sub>" thick (minimum 1<sup>5</sup>/<sub>32</sub>") the above attachment method must be in addition to existing attachment.

**Underlayment:** Minimum underlayment shall be a ASTM D 226 Type II installed with a minimum 4" side-laps and 6" end-laps. Underlayment shall be fastened with corrosion resistant tin-caps and 1<sup>1</sup>/<sub>4</sub>" annular ring-shank nails, spaced 6" o.c. at all laps and two staggered rows 12" o.c. in the field of the roll. Or, any Miami-Dade County Product Control Approved underlayment having a current NOA.

**Fire Barrier Board:** Any approved fire barrier having a current NOA. Refer to a current fire directory listing for fire ratings of this roofing system assembly as well as the location of the fire barrier within the assembly. See Limitation # 1.

**Valleys:** Valley construction shall be in compliance with Roofing Application Standard RAS 133 and with Major's Metal Roofing & Custom Sheet Metal, Inc.'s current published installation instructions.

**Metal Panels and Accessories:** Install the "Steel 1.5" Mechanically Seamed Panel" and accessories in compliance with Major's Metal Roofing & Custom Sheet Metal, Inc.'s current published installation instructions and details. Flashing, penetrations, valley construction and other details shall be constructed in compliance with the minimum requirements provided in Roofing Application Standards RAS 133.

Panels shall be installed with galvanize/stainless steel clips (2" long x 3/4" wide x 1.5" tall), attached to substrate with two corrosion resistant steel #10 wood screw of sufficient length to penetrate through the sheathing a minimum of 3/16". Clip fastening shall start 3" from panel end and shall be at maximum spacing as described below in Table A. there after. Standing seams shall be mechanically seamed to a full 90° seam, (single lock).

<b>TABLE A</b>		
<b>MAXIMUM DESIGN PRESSURES</b>		
<u>Roof Areas</u>	<u>Field</u>	<u>Perimeter and Corner<sup>1</sup></u>
<b>Maximum Design Pressures</b>	<b>-57.3 psf</b>	<b>-101 psf</b>
<b>Maximum Clip Spacing</b>	<b>34" o.c.</b>	<b>8" o.c.</b>
1. Extrapolation shall not be allowed		



**System B:** Steel 1.5" Mechanically Seamed Panel, (Coverage width 12" & 16")  
**Deck Type:** Wood, Non-insulated  
**Deck Description:** New Construction <sup>19</sup>/<sub>32</sub>" or greater plywood or wood plank, or for re-roofing <sup>15</sup>/<sub>32</sub>" or greater plywood.  
**Slope Range:** 2": 12" or greater  
**Maximum Uplift Pressure:** See Table B below

**Deck Attachment:** In accordance with applicable Building Code, but in no case it shall be less than 8d annular ring shank nails spaced 6" o.c. in the field and 4" o.c. along the perimeter of the sheet. In reroofing, where the deck is less than 19/32" thick (minimum 15/32") the above attachment method must be in addition to existing attachment.

**Underlayment:** Minimum underlayment shall be a ASTM D 226 Type II installed with a minimum 4" side-laps and 6" end-laps. Underlayment shall be fastened with corrosion resistant tin-caps and 1 1/4" annular ring-shank nails, spaced 6" o.c. at all laps and two staggered rows 12" o.c. in the field of the roll. Or, any Miami-Dade County Product Control Approved underlayment having a current NOA.

**Fire Barrier Board:** Any approved fire barrier having a current NOA. Refer to a current fire directory listing for fire ratings of this roofing system assembly as well as the location of the fire barrier within the assembly. See Limitation # 1.

**Valleys:** Valley construction shall be in compliance with Roofing Application Standard RAS 133 and with Major's Metal Roofing & Custom Sheet Metal, Inc.'s current published installation instructions.

**Metal Panels and Accessories:** Install the "Steel 1.5" Mechanically Seamed Panel" and accessories in compliance with Major's Metal Roofing & Custom Sheet Metal, Inc.'s current published installation instructions and details. Flashing, penetrations, valley construction and other details shall be constructed in compliance with the minimum requirements provided in Roofing Application Standards RAS 133.

Panels shall be installed with galvanize/stainless steel clips (2" long x 3/4" wide x 1.5" tall), attached to substrate with two corrosion resistant steel #10 wood screw of sufficient length to penetrate through the sheathing a minimum of 3/16". Clip fastening shall start 3" from panel end and shall be at maximum spacing as described below in Table B. there after. Standing seams shall be mechanically seamed to a full 90° seam, (single lock).

**TABLE B  
MAXIMUM DESIGN PRESSURES**

<u>Roof Areas</u>	<u>Field</u>	<u>Perimeter and Corner<sup>1</sup></u>
<b>Maximum Design Pressures</b>	-57.3 psf	-131 psf
<b>Maximum Clip Spacing</b>	34" o.c.	8" o.c.
1. Extrapolation shall not be allowed		



**System C:** Steel 1.5" Mechanically Seamed Panel, (Coverage width 12" & 16")  
**Deck Type:** Wood, Non-insulated  
**Deck Description:** New Construction <sup>19</sup>/<sub>32</sub>" or greater plywood or wood plank, or for re-roofing <sup>15</sup>/<sub>32</sub>" or greater plywood.  
**Slope Range:** 2": 12" or greater  
**Maximum Uplift Pressure:** See Table C below

**Deck Attachment:** In accordance with applicable Building Code, but in no case it shall be less than 8d annular ring shank nails spaced 6" o.c. in the field and 4" o.c. along the perimeter of the sheet. In reroofing, where the deck is less than 19/32" thick (minimum 15/32") the above attachment method must be in addition to existing attachment.

**Underlayment:** Minimum underlayment shall be a ASTM D 226 Type II installed with a minimum 4" side-laps and 6" end-laps. Underlayment shall be fastened with corrosion resistant tin-caps and 1 1/4" annular ring-shank nails, spaced 6" o.c. at all laps and two staggered rows 12" o.c. in the field of the roll. Or, any Miami-Dade County Product Control Approved underlayment having a current NOA.

**Fire Barrier Board:** Any approved fire barrier having a current NOA. Refer to a current fire directory listing for fire ratings of this roofing system assembly as well as the location of the fire barrier within the assembly. See Limitation # 1.

**Valleys:** Valley construction shall be in compliance with Roofing Application Standard RAS 133 and with Major's Metal Roofing & Custom Sheet Metal, Inc.'s current published installation instructions.

**Metal Panels and Accessories:** Install the "Steel 1.5" Mechanically Seamed Panel" and accessories in compliance with Major's Metal Roofing & Custom Sheet Metal, Inc.'s current published installation instructions and details. Flashing, penetrations, valley construction and other details shall be constructed in compliance with the minimum requirements provided in Roofing Application Standards RAS 133.

Panels shall be installed with galvanize/stainless steel clips (2" long x 3/4" wide x 1.5" tall), attached to substrate with two corrosion resistant steel #10 wood screw of sufficient length to penetrate through the sheathing a minimum of 3/16". Clip fastening shall start 3" from panel end and shall be at maximum spacing as described below in Table C there after. Use two 1/4" beads of Titebond WeatherMaster Sealant on the vertical seam when required per Table C (see details herein). Standing seams shall be mechanically seamed to a full 90° seam, (single lock).

**TABLE C**  
**MAXIMUM DESIGN PRESSURES**

<b>Roof Areas</b>	<b>Field</b>	<b>Perimeter and Corner<sup>2</sup></b>	
<b>Maximum Design Pressures</b>	-57.3 psf	-78.5 psf	-168.5 psf
<b>Maximum Clip Spacing</b>	34" o.c.	24" o.c.	12" o.c.
<b>Sealant</b>	n/a	n/a	Yes <sup>3</sup>
2. Extrapolation shall not be allowed			
3. Use two 1/4" beads of Titebond WeatherMaster Sealant.			



## LIMITATIONS

1. Fire classification is not part of this acceptance; refer to a current Approved Roofing Materials Directory for fire ratings of this product.
2. The maximum designed pressure listed herein shall be applicable to all roof pressure zones (i.e. field, perimeters, and corners). Neither rational analysis, nor extrapolation shall be permitted for enhanced fastening at enhanced pressure zones (i.e. perimeters, extended corners and corners).
3. Panels shall be roll formed in continuous lengths from eave to ridge. Maximum lengths shall be as described in Roofing Application Standard RAS 133.
4. All panels shall be permanently labeled with the manufacturer's name and/or logo, and the following statement: "Miami-Dade County Product Control Approved" or with the Miami-Dade County Product Control Seal as seen below. All clips shall be permanently labeled with the manufacturer's name and/or logo, and/or model.



5. All products listed herein shall have a quality assurance audit in accordance with the Florida Building Code and Rule 61G20-3 of the Florida Administrative Code.



## DETAIL DRAWINGS

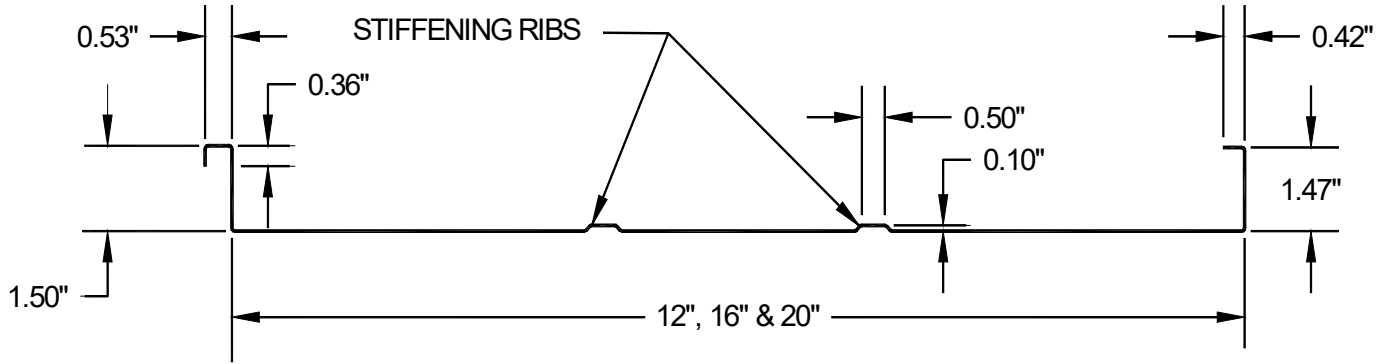

## PANEL DETAIL

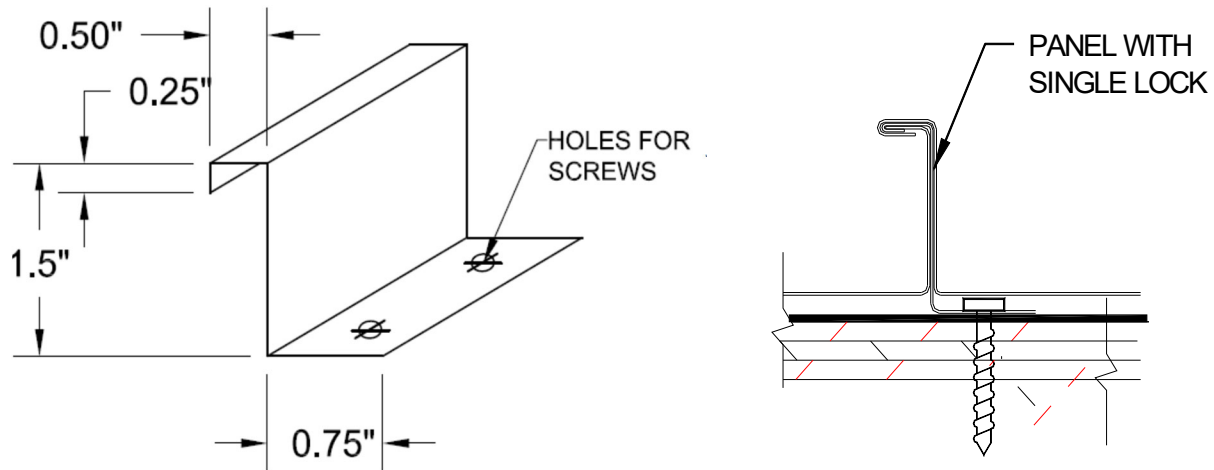

## PANEL CLIP DETAIL

### STEEL 1.5" MECHANICALLY SEAMED PANEL AND DETAILS



**DRAWINGS CONT.**

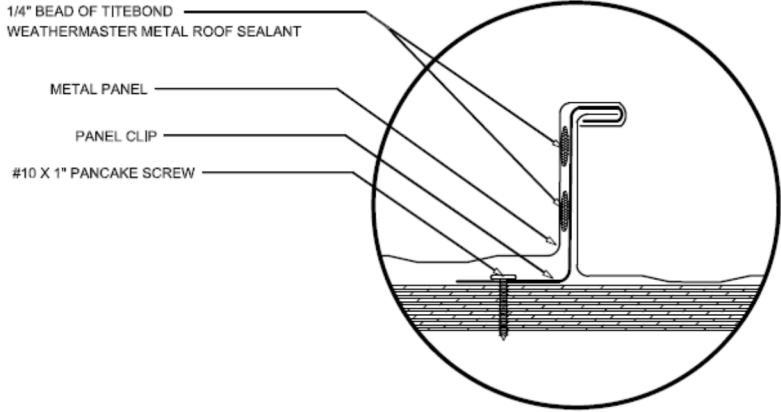

**SYSTEM C – PERIMETER AND CORNER SEALANT DETAIL**

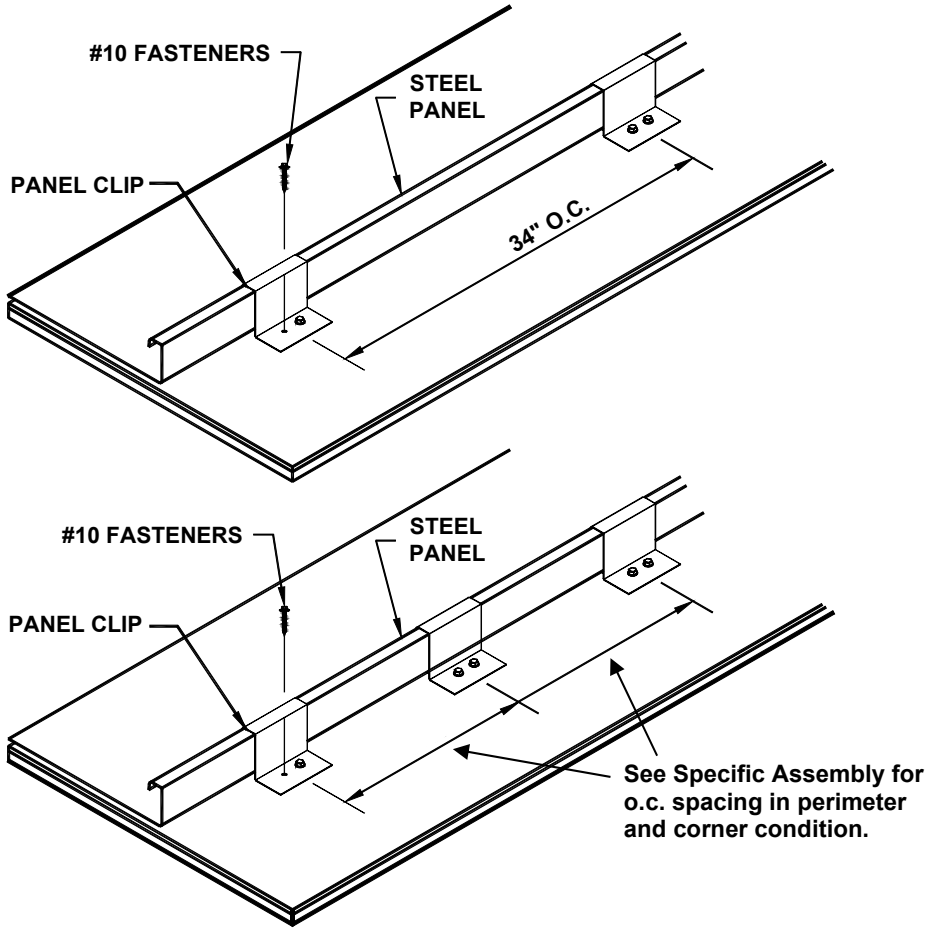

**END OF THIS ACCEPTANCE**

