



MIAMI-DADE COUNTY
 PRODUCT CONTROL SECTION
 11805 SW 26 Street, Room 208
 Miami, Florida 33175-2474
 T (786) 315-2590 F (786) 315-2599
www.miamidade.gov/building

DEPARTMENT OF REGULATORY AND ECONOMIC RESOURCES (RER)
 BOARD AND CODE ADMINISTRATION DIVISION
NOTICE OF ACCEPTANCE (NOA)

Florida Window Systems Corp.
 7191 NW 77th Terrace
 Medley, FL 33166

SCOPE:

This NOA is being issued under the applicable rules and regulations governing the use of construction materials. The documentation submitted has been reviewed and accepted by Miami-Dade County RER–Product Control Section to be used in Miami-Dade County and other areas where allowed by the Authority Having Jurisdiction (AHJ).

This NOA shall not be valid after the expiration date stated below. The Miami-Dade County Product Control Section (In Miami-Dade County) and/ or the AHJ (in areas other than Miami-Dade County) reserve the right to have this product or material tested for quality assurance purposes. If this product or material fails to perform in the accepted manner, the manufacturer will incur the expense of such testing and the AHJ may immediately revoke, modify, or suspend the use of such product or material within their jurisdiction. RER reserves the right to revoke this acceptance if it is determined by Miami-Dade County Product Control Section that this product or material fails to meet the requirements of the applicable building code.

This product is approved as described herein and has been designed to comply with the Florida Building Code, including the High Velocity Hurricane Zone.

DESCRIPTION: Outswing Aluminum Casement Window – L.M.I.

APPROVAL DOCUMENT: Drawing No **W03-36**, titled “Alum Outswing Casement Window (L.M.I.)”, sheets 1 through 6 of 6, dated 05/28/03, with revision **H** dated 07/13/23, prepared by Al-Farooq Corporation, signed and sealed by Jalal Farooq, P.E., bearing the Miami-Dade County Product Control Renewal stamp with the Notice of Acceptance number and expiration date by the Miami-Dade County Product Control Section.

MISSILE IMPACT RATING: Large and Small Missile Impact Resistant

LABELING: Each unit shall bear a permanent label with the manufacturer's name or logo, city, state, model/series, and following statement: "Miami-Dade County Product Control Approved", unless otherwise noted herein.

RENEWAL of this NOA shall be considered after a renewal application has been filed and there has been no change in the applicable building code negatively affecting the performance of this product.

TERMINATION of this NOA will occur after the expiration date or if there has been a revision or change in the materials, use, and/ or manufacture of the product or process. Misuse of this NOA as an endorsement of any product, for sales, advertising or any other purposes shall automatically terminate this NOA. Failure to comply with any section of this NOA shall be cause for termination and removal of NOA.

ADVERTISEMENT: The NOA number preceded by the words Miami–Dade County, Florida, and followed by the expiration date may be displayed in advertising literature. If any portion of the NOA is displayed, then it shall be done in its entirety.

INSPECTION: A copy of this entire NOA shall be provided to the user by the manufacturer or its distributors and shall be available for inspection at the job site at the request of the Building Official.

This NOA **renews NOA No. 23-0928.26** and consists of this page 1 and evidence pages E-1, E-2 and E-3, as well as approval document mentioned above.

The submitted documentation was reviewed by **Manuel Perez, P.E.**

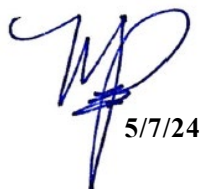

 5/7/24

No. 24-0417.01
 Expiration Date: June 27, 2025
 Approval Date: May 16, 2024
 Page 1

Florida Window Systems Corp.

NOTICE OF ACCEPTANCE: EVIDENCE SUBMITTED

1. EVIDENCE SUBMITTED UNDER PREVIOUS NOA's

A. DRAWINGS

1. Manufacturer's die drawings and sections.
(Submitted under NOA No. 03-0612.04)
2. Drawing No. **W03-36**, titled "Alum Outswing Casement Window (L.M.I.)", sheets 1 through 6 of 6, dated 05/28/03, with revision **H** dated 07/13/23, prepared by Al-Farooq Corporation, signed and sealed by Jalal Farooq, P.E.
(Submitted under NOA No. 23-0928.26)

B. TESTS

1. Test reports on: 1) Air Infiltration Test, per FBC, TAS 202-94
2) Uniform Static Air Pressure Test, Loading per FBC, TAS 202-94
3) Water Resistance Test, per FBC, TAS 202-94
along with marked-up drawings and installation diagram of an aluminum casement window, prepared by Hurricane Engineering & Testing, Inc. Test Report No. **HETI-03-1312** dated 04/17/03, signed and sealed by Rafael Droz, P.E.
(Submitted under NOA No. 03-0612.04)
2. Test reports on: 1) Large Missile Impact Test per FBC, TAS 201-94
2) Cyclic Wind Pressure Loading per FBC, TAS 203-94
along with marked-up drawings and installation diagram of an aluminum casement vinyl window, prepared by Hurricane Engineering & Testing, Inc. Test Report No. **HETI-02-1752** dated 12/03/02, signed and sealed by Rafael Droz-Seda, P.E.
(Submitted under NOA No. 03-0612.04)
3. Test reports on: 1) Air Infiltration Test, per FBC, TAS 202-94
2) Uniform Static Air Pressure Test, Loading per FBC, TAS 202-94
3) Water Resistance Test, per FBC, TAS 202-94
along with marked-up drawings and installation diagram of an aluminum casement vinyl window, prepared by Hurricane Engineering & Testing, Inc. Test Report No. **HETI-02-1230** dated 06/23/02, signed and sealed by Rafael Droz-Seda, P.E.
(Submitted under NOA No. 03-0612.04)
4. Test reports on: 1) Large Missile Impact Test per FBC, TAS 201-94
2) Cyclic Wind Pressure Loading per FBC, TAS 203-94
along with marked-up drawings and installation diagram of an aluminum casement vinyl window, prepared by Hurricane Engineering & Testing, Inc. Test Report No. **HETI-02-1751** dated 12/03/02, signed and sealed by Rafael Droz-Seda, P.E.
(Submitted under NOA No. 03-0612.04)



Manuel Perez, P.E.
Product Control Examiner
NOA No. 24-0417.01
Expiration Date: June 27, 2025
Approval Date: May 16, 2024

Florida Window Systems Corp.

NOTICE OF ACCEPTANCE: EVIDENCE SUBMITTED

1. EVIDENCE SUBMITTED UNDER PREVIOUS NOA's (CONTINUED)

B. TESTS (CONTINUED)

5. Test reports on: 1) Air Infiltration Test, per FBC, TAS 202-94
2) Uniform Static Air Pressure Test, Loading per FBC, TAS 202-94
3) Water Resistance Test, per FBC, TAS 202-94
along with marked-up drawings and installation diagram of an aluminum casement vinyl window, prepared by Hurricane Engineering & Testing, Inc. Test Report No. **HETI-02-1235** dated 07/03/02, signed and sealed by Rafael Droz-Seda, P.E.
(Submitted under NOA No. 03-0612.04)

C. CALCULATIONS

1. Anchor verification calculations and structural analysis, complying with FBC 6th Edition (2017), dated 05/13/19 and updated on 11/27/20 to comply with FBC 7th Edition (2020), prepared by Al-Farooq Corporation, signed and sealed by Jalal Farooq, P.E.
(Submitted under NOA No. 21-0114.08)
2. Glazing complies with **ASTM E1300-09**

D. QUALITY ASSURANCE

1. Miami-Dade Department of Regulatory and Economic Resources (RER)

E. MATERIAL CERTIFICATIONS

1. Notice of Acceptance No. **21-0216.01** issued to **Eastman Chemical Company (MA)** for their "**Saflex PVB Interlayers - Clear and Colored for Glass**" dated 04/29/21, expiring on 05/21/26.
2. Notice of Acceptance No. **23-0523.01** issued to **Polymer Extrusion Technology, Inc. dba Glasslam** for their "**Glasslam Safety-Plus II Glass Interlayer**" dated 06/15/23, expiring on 08/07/28.

F. STATEMENTS

1. Statement letter of conformance, complying with **FBC 7th Edition (2020)**, with **FBC 8th Edition (2023)** and of no financial interest, dated July 18, 2023, issued by Al-Farooq Corporation, signed and sealed by Jalal Farooq, P.E.
(Submitted under NOA No. 23-0928.26)

G. OTHERS

1. Notice of Acceptance No. **21-0114.08**, issued to Florida Window Systems Corp. for their Outswing Aluminum Casement Window – L.M.I., approved on 04/15/21 and expiring on 06/27/24.

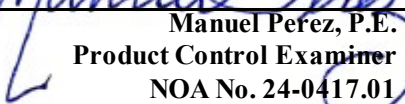
Manuel Perez, P.E.
Product Control Examiner
NOA No. 24-0417.01
Expiration Date: June 27, 2025
Approval Date: May 16, 2024

Florida Window Systems Corp.

NOTICE OF ACCEPTANCE: EVIDENCE SUBMITTED

2. NEW EVIDENCE SUBMITTED

A. DRAWINGS

1. None.

B. TESTS

1. None.

C. CALCULATIONS

1. None.

D. QUALITY ASSURANCE

1. Miami-Dade Department of Regulatory and Economic Resources (RER)

E. MATERIAL CERTIFICATIONS

1. Notice of Acceptance No. **23-0713.18** issued to **Eastman Chemical Company (MA)** for their “**Saflex® PVB Clear and Colored Interlayers for Laminated Glass**” dated 08/17/23, expiring on 05/21/26.
2. Notice of Acceptance No. **23-0523.01** issued to **Polymer Extrusion Technology, Inc. dba Glasslam** for their “**Glasslam Safety-Plus II Glass Interlayer**” dated 06/15/23, expiring on 08/07/28.

F. STATEMENTS

1. Statement letter of conformance, complying with **FBC 8th Edition (2023)** and of no financial interest, dated April 16, 2024, issued by Al-Farooq Corporation, signed and sealed by Jalal Farooq, P.E.
2. Letter from consultant requesting a 1-year extension to allow time to perform verification test, dated 04/15/24 issued by Al-Farooq Corporation, signed and sealed by Jalal Farooq, P.E.
3. Testing agreement letter dated 05/01/24 between Florida Window Systems Corp. and Hurricane Engineering & Testing Inc., issued by HETI and signed by Dr. Syed Waqar Ali, Ph.D., president.

G. OTHERS

1. Notice of Acceptance No. **23-0928.26**, issued to Florida Window Systems Corp. for their Outswing Aluminum Casement Window – L.M.I., approved on 11/09/23 and expiring on 06/27/24.
2. This is a one-year approval, subjected to successful verification test, the final approval will be issued for a total of 5 years.



Manuel Perez, P.E.
Product Control Examiner
NOA No. 24-0417.01
Expiration Date: June 27, 2025
Approval Date: May 16, 2024

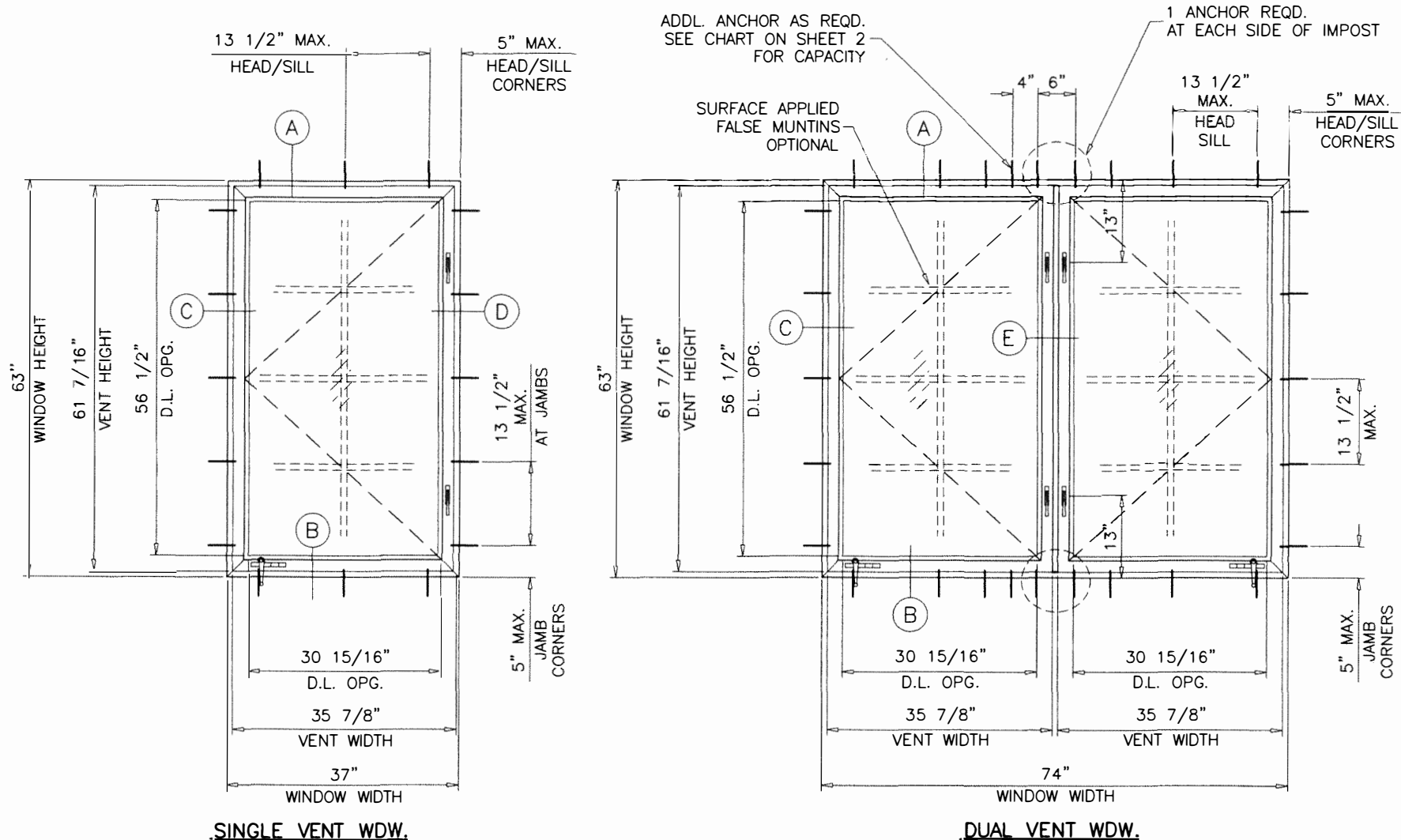

SINGLE VENT WDW.

DUAL VENT WDW.

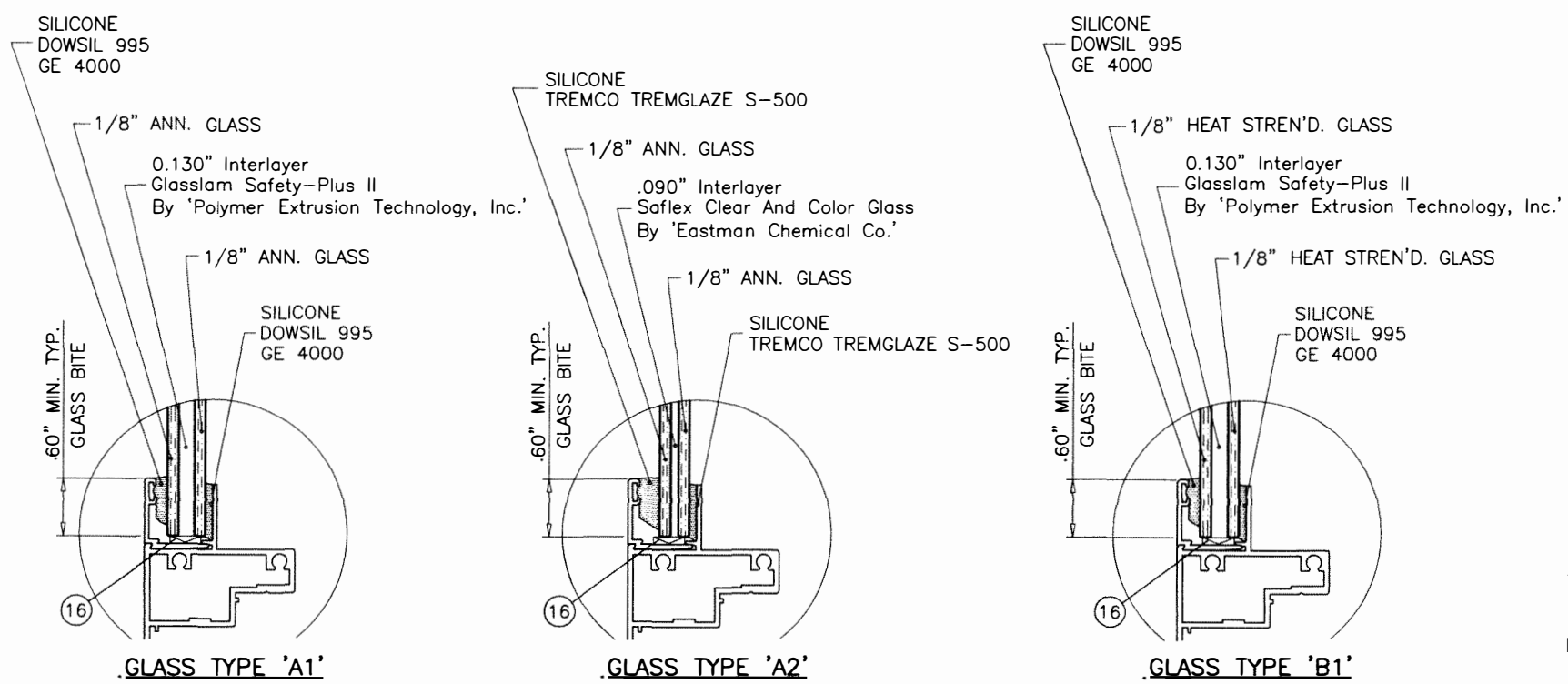

GLAZING OPTIONS

PRODUCT RENEWED
 as complying with the Florida
 Building Code
 NOA-No. **24-0417.01**
 Expiration Date: **06/27/2025**
 By: *Manuel Perez*
 Miami-Dade Product Control

THESE WINDOWS ARE RATED FOR LARGE MISSILE IMPACT.
 SHUTTERS ARE NOT REQUIRED.

ALUMINUM OUTSWING CASEMENT WINDOW

DESIGN LOAD RATINGS FOR THESE WINDOWS TO BE AS PER CHARTS SHOWN ON SHEET 2.

APPROVAL APPLIES TO SINGLE VENT OR DUAL VENT WINDOWS WITH X AND XX CONFIGURATIONS.

ALSO COMBINATIONS OF CASMT/CASMT OR CASMT WITH OTHER WINDOW TYPES IN MODULES OF TWO OR MORE WINDOWS USING MIAMI-DADE COUNTY APPROVED MULLIONS IN BETWEEN.

LOWER DESIGN PRESSURE FROM WINDOWS OR MULLION APPROVAL WILL APPLY TO ENTIRE SYSTEM.

THIS PRODUCT HAS BEEN DESIGNED AND TESTED TO COMPLY WITH THE REQUIREMENTS OF THE 2020 (7TH EDITION)/2023 (8TH EDITION) FLORIDA BUILDING CODE INCLUDING HIGH VELOCITY HURRICANE ZONE (HVHZ).

1BY OR 2BY WOOD BUCKS & BUCK FASTENERS BY OTHERS, MUST BE DESIGNED AND INSTALLED ADEQUATELY TO TRANSFER APPLIED PRODUCT LOADS TO THE BUILDING STRUCTURE.

ANCHORS SHALL BE CORROSION RESISTANT, SPACED AS SHOWN ON DETAILS AND INSTALLED PER MANUF'S INSTRUCTIONS. SPECIFIED EMBEDMENT TO BASE MATERIAL SHALL BE BEYOND WALL DRESSING OR STUCCO.

A LOAD DURATION INCREASE IS USED IN DESIGN OF ANCHORS INTO WOOD ONLY. ALL SHIMS TO BE HIGH IMPACT, NON-METALLIC AND NON-COMPRESSIBLE.

MATERIALS INCLUDING BUT NOT LIMITED TO STEEL/METAL SCREWS, THAT COME INTO CONTACT WITH OTHER DISSIMILAR MATERIALS SHALL MEET THE REQUIREMENTS OF THE 2020/2023 FLORIDA BLDG. CODE & ADOPTED STANDARDS.

THIS PRODUCT APPROVAL IS GENERIC AND DOES NOT PROVIDE INFORMATION FOR A SITE SPECIFIC PROJECT, i.e. LIFE SAFETY OF THIS PRODUCT, ADEQUACY OF STRUCTURE RECEIVING THIS PRODUCT AND SEALING AROUND OPENING FOR WATER INFILTRATION RESISTANCE ETC. CONDITIONS NOT SHOWN IN THIS DRAWING ARE TO BE ANALYZED SEPARATELY, AND TO BE REVIEWED BY BUILDING OFFICIAL.

DESIGN LOADS SHOWN ARE BASED ON 'ALLOWABLE STRESS DESIGN (ASD)'

PRODUCT REVISED
 As complying with the Florida
 Building Code
 NOA-No. **23-0928.26**
 Expiration Date: **06/27/2024**
 By: *Manuel Perez*
 Miami-Dade Product Control

JUL 19 2023

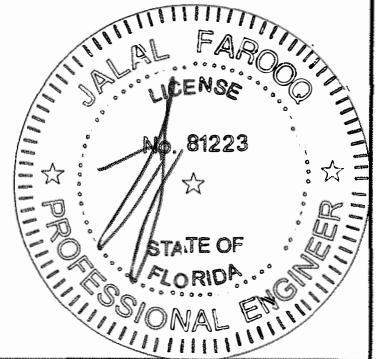

af c
AL-FAROOQ CORPORATION
 ENGINEERS & PRODUCT DEVELOPMENT
 9360 SUNSET DRIVE, SUITE 220 (C.A.N. 3538)
 MIAMI, FLORIDA 33173 TEL. (305) 264-8100 FAX. (305) 262-6978
 COMP-ANL\W03-36FWS

ALUM OUTSWING CASEMENT WINDOW (L.M.I.)
FLORIDA WINDOW SYSTEMS CORP.
 7191 N.W. 77 TERRACE
 MEDLEY, FL. 33166
 TEL. (305) 805-9420 FAX (305) 805-9424

no.	date	by	description
E	09.11.14		UPDATED TO 2014 FBC
F	05.10.19		UPDATED TO 2017 FBC
G	11.05.20		UPDATED TO 2020 FBC
H	07.13.23		UPDATED TO 2023 FBC

date: 05-28-03
 scale: 1/2"=1'-0"
 dr. by: TARIQ
 chk. by:

drawing no. **W03-36**
 sheet 1 of 6

DESIGN LOAD CAPACITY - PSF FOR (X) SIZES					
WINDOW DIMS.		GLASS TYPES 'A1' & 'A2'		GLASS TYPE 'B1'	
WIDTH	HEIGHT	EXT. (+)	INT. (-)	EXT. (+)	INT. (-)
19-1/8"	26" (3)	55.0	55.0	75.0	80.0
26-1/2"		55.0	55.0	75.0	80.0
37"		55.0	55.0	75.0	80.0
19-1/8"	38-3/8" (4)	55.0	55.0	75.0	80.0
26-1/2"		55.0	55.0	75.0	80.0
37"	50-5/8" (5)	55.0	55.0	75.0	80.0
26-1/2"		55.0	55.0	75.0	80.0
37"		55.0	55.0	75.0	80.0
19-1/8"	63" (5)	45.5	45.5	75.0	80.0
26-1/2"		34.0	34.0	75.0	80.0
37"		-	-	75.0	80.0
19-1/8"	74-1/4" (6)	27.5	27.5	75.0	80.0
26-1/2"		-	-	66.8	66.8
18"	24" (3)	55.0	55.0	75.0	80.0
24"		55.0	55.0	75.0	80.0
30"		55.0	55.0	75.0	80.0
36"		55.0	55.0	75.0	80.0
18"	36" (3)	55.0	55.0	75.0	80.0
24"		55.0	55.0	75.0	80.0
30"		55.0	55.0	75.0	80.0
36"		55.0	55.0	75.0	80.0
18"	48" (4)	55.0	55.0	75.0	80.0
24"		55.0	55.0	75.0	80.0
30"		55.0	55.0	75.0	80.0
36"		55.0	55.0	75.0	80.0
18"	60" (5)	55.0	55.0	75.0	80.0
24"		43.2	43.2	75.0	80.0
30"		35.9	35.9	75.0	80.0
36"		-	-	75.0	80.0
18"	72" (6)	32.0	32.0	75.0	80.0
24"		24.5	24.5	75.0	80.0
30"		-	-	66.0	66.0

() = NO. OF ANCHORS PER JAMB

NOTE:
GLASS CAPACITIES ON THIS SHEET ARE
BASED ON ASTM E1300-09 (3 SEC. GUSTS)
AND FLORIDA BUILDING COMMISSION
DECLARATORY STATEMENT DCA05-DEC-219

PRODUCT RENEWED
as complying with the Florida
Building Code
NOA-No. 24-0417.01
Expiration Date: 06/27/2025
By: Manuel Perez
Miami-Dade Product Control

PRODUCT REVISED
As complying with the Florida
Building Code
NOA-No. 23-0928.26
Expiration Date: 06/27/2024
By: Manuel Perez
Miami-Dade Product Control

JUL 19 2023

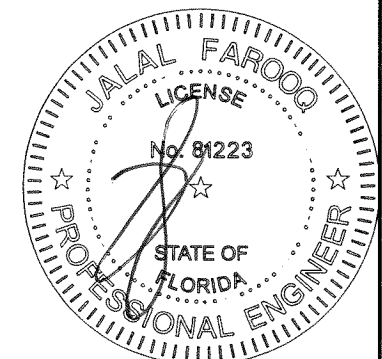

DESIGN LOAD CAPACITY - PSF FOR (XX) SIZES							
WINDOW DIMS.		UNREINFORCED CENTER POST				REINFORCED CENTER POST	
		GLASS TYPES 'A1' & 'A2'		GLASS TYPE 'B1'		GLASS TYPE 'B1'	
WIDTH	HEIGHT	EXT. (+)	INT. (-)	EXT. (+)	INT. (-)	EXT. (+)	INT. (-)
26-1/2"	26" (3)	55.0	55.0	75.0	80.0	75.0	80.0
37"		55.0	55.0	75.0	80.0	75.0	80.0
53-1/8"		55.0	55.0	75.0	80.0	75.0	80.0
74"		55.0	55.0	75.0	80.0	75.0	80.0
26-1/2"	38-3/8" (4)	55.0	55.0	75.0	80.0	75.0	80.0
37"		55.0	55.0	75.0	80.0	75.0	80.0
53-1/8"		55.0	55.0	75.0	80.0	75.0	80.0
74"	50-5/8" (5)	55.0	55.0	75.0	80.0	75.0	80.0
26-1/2"		55.0	55.0	75.0	80.0	75.0	80.0
37"		55.0	55.0	75.0	80.0	75.0	80.0
53-1/8"		55.0	55.0	75.0	80.0	75.0	80.0
74"	63" (5)	55.0	55.0	65.7	65.7	75.0	80.0
26-1/2"		55.0	55.0	75.0	80.0	75.0	80.0
37"		47.0	47.0	61.5	61.5	75.0	80.0
53-1/8"		34.0	34.0	44.5	44.5	75.0	80.0
74"	74-1/4" (6)	-	-	34.3	34.3	61.8	61.8
26-1/2"		39.2	39.2	51.3	51.3	75.0	80.0
37"		28.4	28.4	37.2	37.2	74.0	74.0
53-1/8"		-	-	26.6	26.6	52.9	52.9
24"	24" (3)	55.0	55.0	75.0	80.0	75.0	80.0
36"		55.0	55.0	75.0	80.0	75.0	80.0
48"		55.0	55.0	75.0	80.0	75.0	80.0
60"		55.0	55.0	75.0	80.0	75.0	80.0
72"	36" (3)	55.0	55.0	75.0	80.0	75.0	80.0
24"		55.0	55.0	75.0	80.0	75.0	80.0
36"		55.0	55.0	75.0	80.0	75.0	80.0
48"		55.0	55.0	75.0	80.0	75.0	80.0
60"	48" (4)	55.0	55.0	75.0	80.0	75.0	80.0
24"		55.0	55.0	75.0	80.0	75.0	80.0
36"		55.0	55.0	75.0	80.0	75.0	80.0
48"		55.0	55.0	75.0	80.0	75.0	80.0
60"	60" (5)	55.0	55.0	75.0	80.0	75.0	80.0
24"		55.0	55.0	75.0	80.0	75.0	80.0
36"		55.0	55.0	73.3	73.3	75.0	80.0
48"		43.2	43.2	56.6	56.6	75.0	80.0
60"	72" (6)	35.9	35.9	47.0	47.0	75.0	80.0
24"		-	-	41.1	41.1	70.4	70.4
36"		47.4	47.4	62.1	62.1	75.0	80.0
48"		32.0	32.0	41.9	41.9	75.0	80.0
60"	72" (6)	24.5	24.5	32.1	32.1	63.8	63.8
24"		-	-	26.3	26.3	52.4	52.4
36"		-	-	26.3	26.3	52.4	52.4

() = NO. OF ANCHORS PER JAMB

af c
AL-FAROOQ CORPORATION
ENGINEERS & PRODUCT DEVELOPMENT
9360 SUNSET DRIVE, SUITE 220
MIAMI, FLORIDA 33173 (C.A.N. 3538)
TEL. (305) 262-6978 FAX. (305) 262-8100
COMP-ANL\W03-36FWS

ALUM OUTSWING CASEMENT WINDOW (L.M.I.)
FLORIDA WINDOW SYSTEMS CORP.
7191 N.W. 77 TERRACE
MEDLEY, FL. 33166
TEL. (305) 805-9420 FAX (305) 805-9424

no	date	description
E	09.11.14	NO CHANGE THIS SHEET
F	05.10.19	UPDATED TO 2017 FBC
G	11.05.20	UPDATED TO 2020 FBC
H	07.13.23	NO CHANGE THIS SHEET

date: 05-28-03
scale: 1/2" = 1"
dr. by: TARIQ
chk. by:
drawing no.
W03-36
sheet 2 of 6

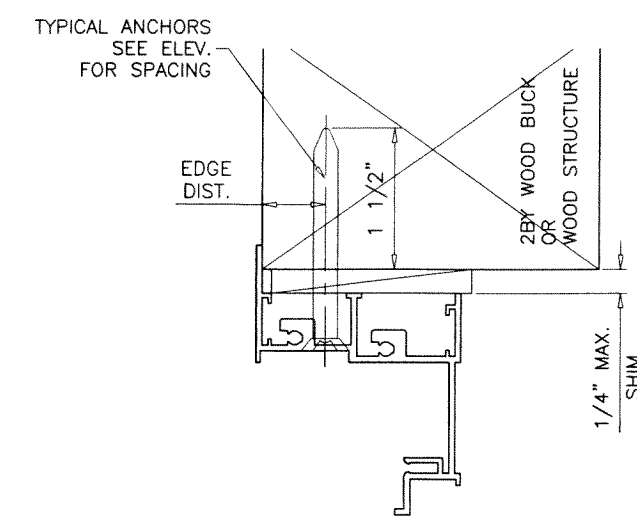
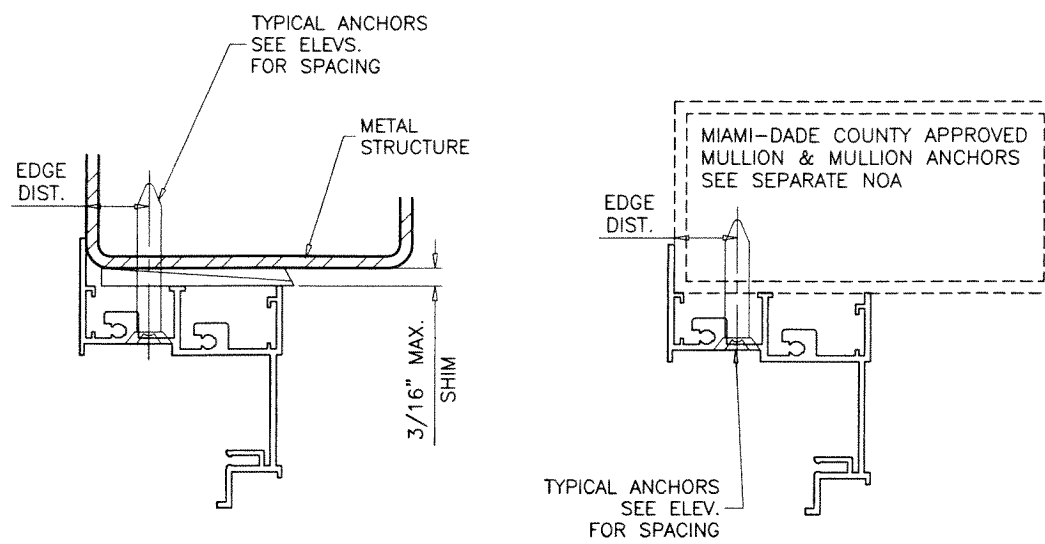
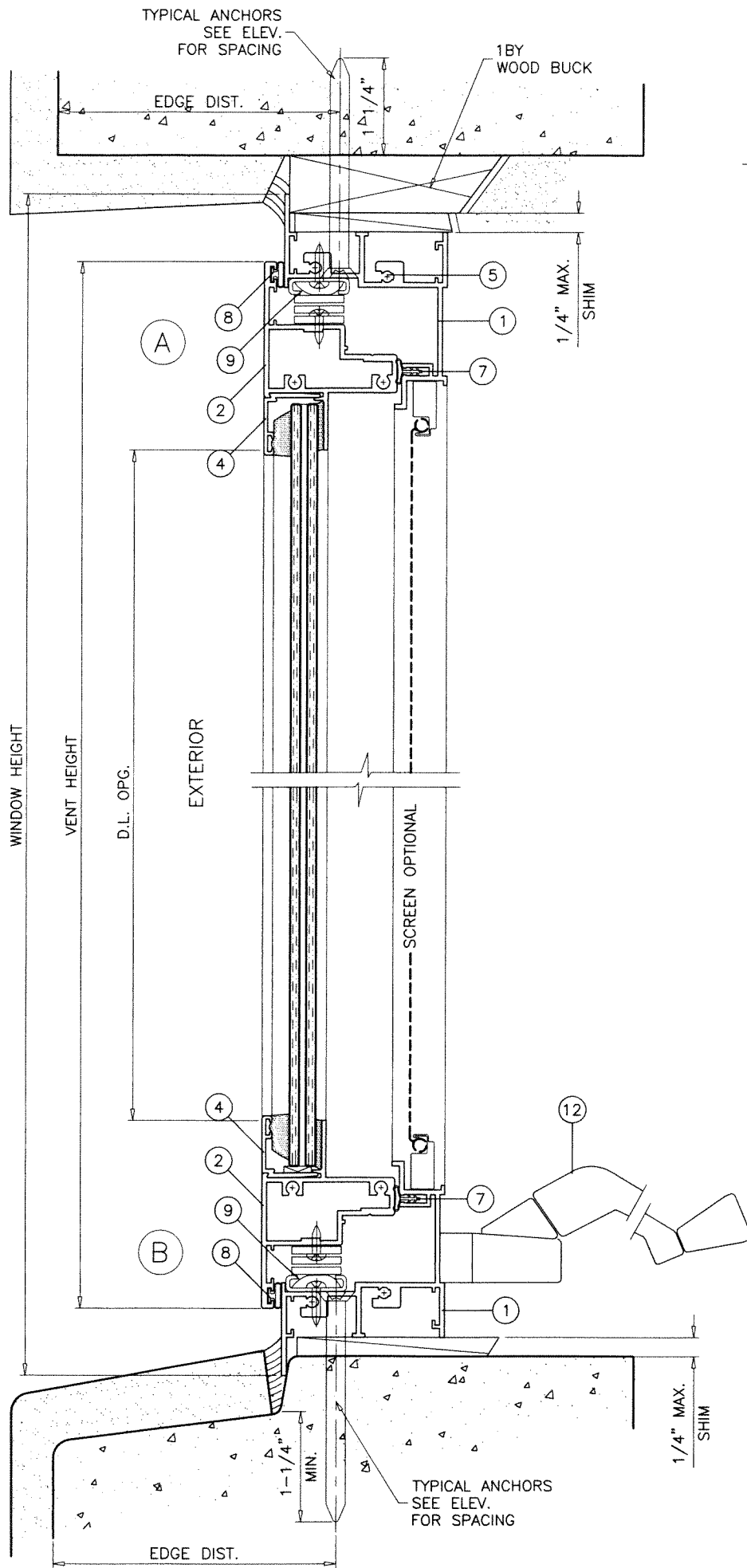

WOOD BUCKS AND METAL STRUCTURE NOT BY 'FLORIDA WDW. SYS.' MUST SUSTAIN LOADS IMPOSED BY GLAZING SYSTEM AND TRANSFER THEM TO THE BUILDING STRUCTURE.

SEALANTS:

ALL FRAME AND VENT CORNERS AND INSTALLATION SCREWS SEALED WITH CLEAR/ALUMINUM COLORED SEALANT.

TYPICAL ANCHORS: SEE ELEV. FOR SPACING

- 1/4" DIA. TAPCON BY 'ITW'** (Fu=125 KSI, Fy=100 KSI) INTO 2BY WOOD BUCKS OR WOOD STRUCTURES 1-1/2" MIN. PENETRATION INTO WOOD (HEAD/SILL/JAMBS) THRU 1BY BUCKS INTO CONC. OR BLOCKS 1-1/4" MIN. EMBED INTO CONCRETE (HEAD/SILL/JAMBS) 1-1/4" MIN. EMBED INTO BLOCKS (JAMBS)
- DIRECTLY INTO CONCRETE OR BLOCKS 1-1/4" MIN. EMBED INTO CONCRETE (HEAD/SILL/JAMBS) 1-1/4" MIN. EMBED INTO BLOCKS (JAMBS)

- #12 SMS OR SELF-DRILLING SCREWS** (GRADE 2 CRS) INTO MIAMI-DADE COUNTY APPROVED MULLIONS AND INTO METAL STRUCTURES (HEAD/SILL/JAMBS) (3) THREADS MIN. TO EXTEND BEYOND METAL THICKNESS ALUMINUM: 1/8" THK. MIN. (6063-T5 MIN.) STEEL: 1/8" THK. MIN. (Fy = 36 KSI MIN.) (STEEL IN CONTACT WITH ALUMINUM TO BE PLATED OR PAINTED)

CRITICAL EDGE DISTANCE

- INTO CONCRETE AND BLOCKS = 2-1/2" MIN.
- INTO WOOD STRUCTURE = 1" MIN.
- INTO METAL STRUCTURE = 3/4" MIN.

- WOOD AT HEAD, SILL OR JAMBS SG = 0.55 MIN.
- CONCRETE AT HEAD, SILL OR JAMBS f'c = 3000 PSI MIN.
- C-90 HOLLOW/FILLED BLOCK AT JAMBS f'm = 2000 PSI MIN.

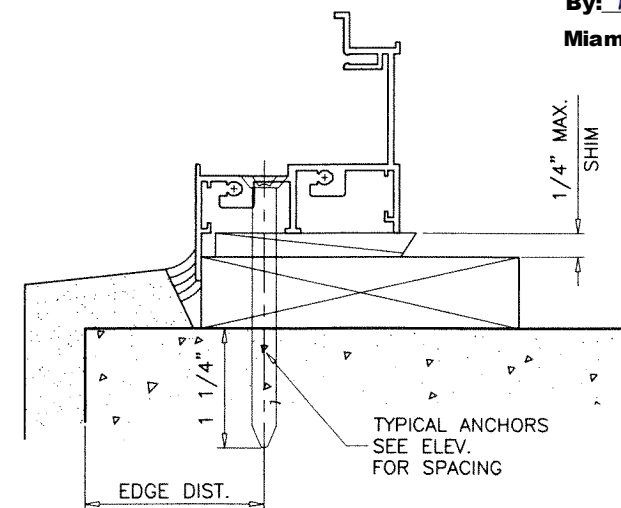

PRODUCT RENEWED
 as complying with the Florida Building Code
 NOA-No. **24-0417.01**
 Expiration Date: **06/27/2025**
 By: *Manuel Perez*
 Miami-Dade Product Control

PRODUCT REVISED
 As complying with the Florida Building Code
 NOA-No. **23-0928.26**
 Expiration Date: **06/27/2024**
 By: *Manuel Perez*
 Miami-Dade Product Control

JUL 19 2023

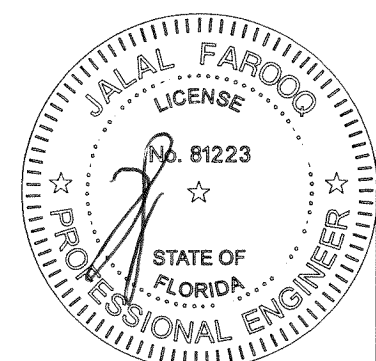

AL-FAROOQ CORPORATION
 ENGINEERS & PRODUCT DEVELOPMENT
 9360 SUNSET DRIVE, SUITE 220
 MIAMI, FLORIDA 33173
 TEL. (305) 264-8100 FAX. (305) 262-6978
 (C.A.N. 3538)

ALUM OUTSWING CASEMENT WINDOW (L.M.I.)
FLORIDA WINDOW SYSTEMS CORP.
 7191 N.W. 77 TERRACE
 MEDLEY, FL. 33166
 TEL. (305) 805-9420 FAX (305) 805-9424

no	date	by	description
E	09.11.14		UPDATED TO 2014 FBC
F	05.10.19		UPDATED TO 2017 FBC
G	11.05.20		UPDATED TO 2020 FBC
H	07.13.23		NO CHANGE THIS SHEET

date: 05-28-03
 scale: 1/2" = 1"
 dr. by: TARIQ
 chk. by:

drawing no.
W03-36
 sheet 3 of 6

COMP-ANL\W03-36FWS

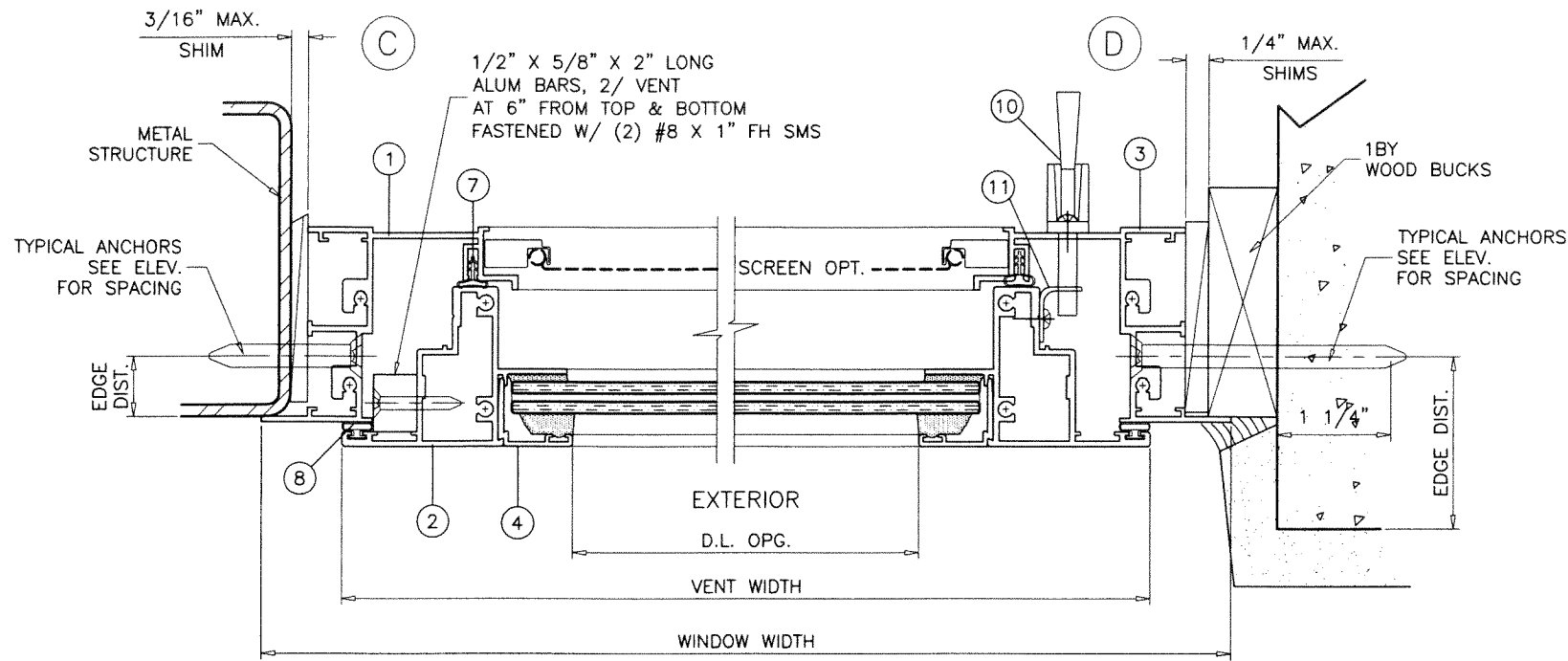

SINGLE VENT WINDOWS

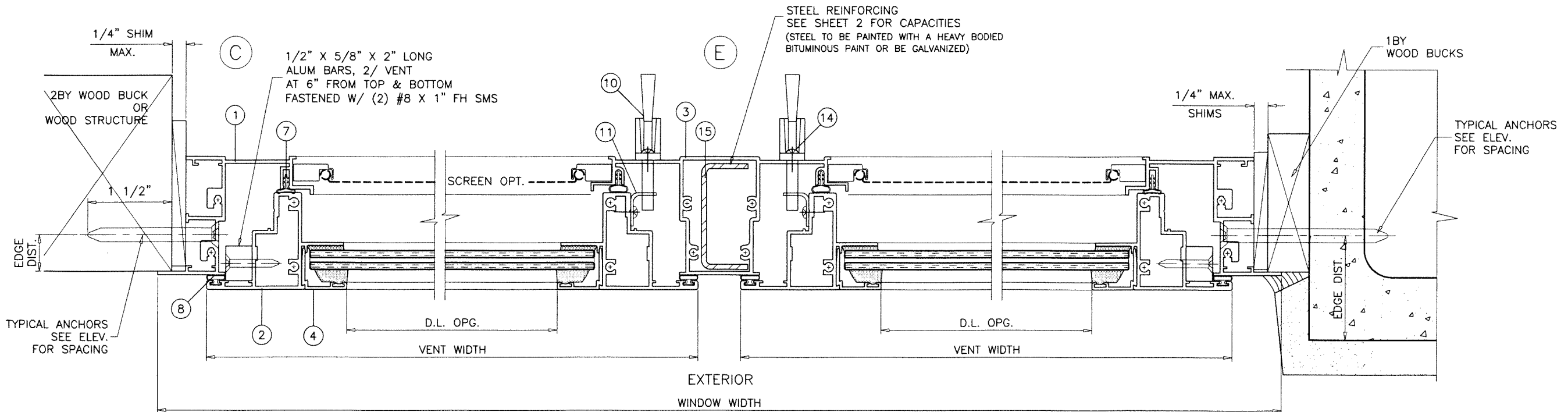
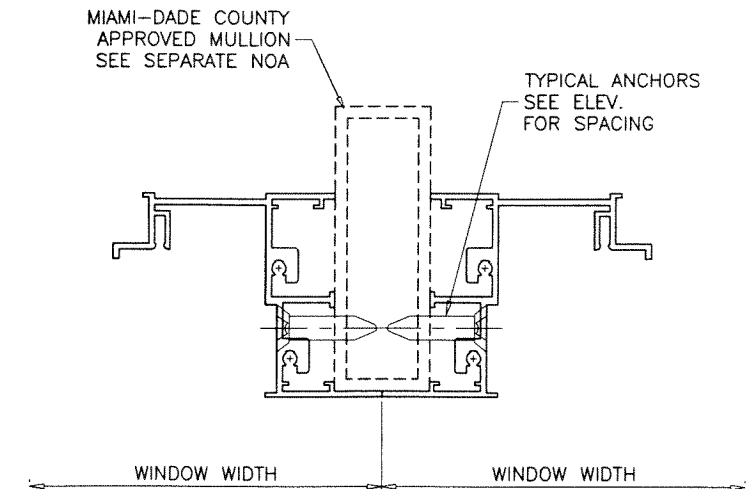

DUAL VENT WINDOWS

PRODUCT RENEWED
 as complying with the Florida
 Building Code
 NOA-No. 24-0417.01
 Expiration Date: 06/27/2025
 By: *Manuel Perez*
 Miami-Dade Product Control

PRODUCT REVISED
 As complying with the Florida
 Building Code
 NOA-No. 23-0928.26
 Expiration Date: 06/27/2024
 By: *Manuel Perez*
 Miami-Dade Product Control

JUL 19 2023

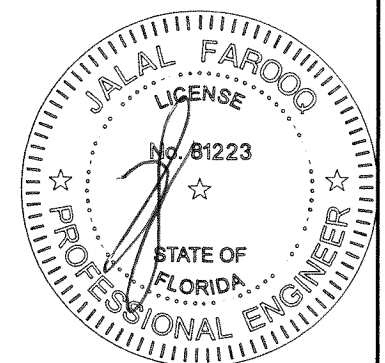

af c
AL-FAROOQ CORPORATION
 ENGINEERS & PRODUCT DEVELOPMENT
 9360 SUNSET DRIVE, SUITE 220
 MIAMI, FLORIDA 33173 (C.A.N. 3538)
 TEL. (305) 264-8100 FAX. (305) 262-6978
 COMP-ANL\W03-36FWS

ALUM OUTSWING CASEMENT WINDOW (L.M.I.)
FLORIDA WINDOW SYSTEMS CORP.
 7191 N.W. 77 TERRACE
 MEDLEY, FL. 33166
 TEL. (305) 805-9420 FAX (305) 805-9424

no	date	by	description
E	09.11.14		NO CHANGE THIS SHEET
F	05.10.19		UPDATED TO 2017 FBC
G	11.05.20		UPDATED TO 2020 FBC
H	07.13.23		NO CHANGE THIS SHEET

date: 05-28-03
 scale: 1/2" = 1"
 dr. by: TARIQ
 chk. by:
 drawing no.
W03-36
 sheet 4 of 6

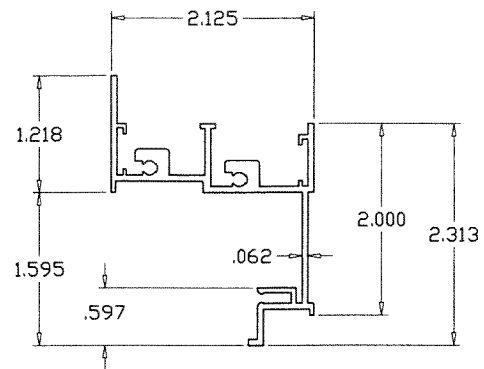

FRAME

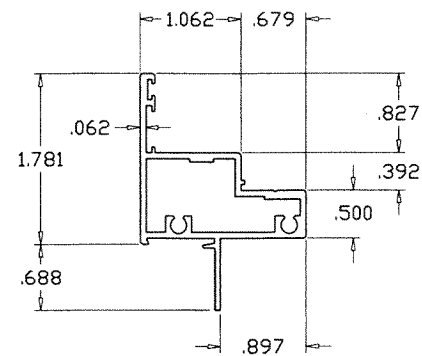

VENT

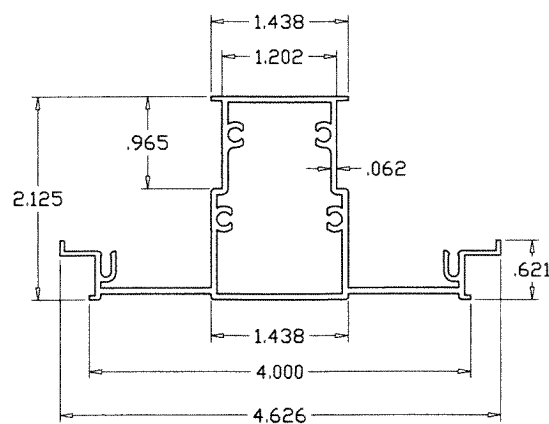

IMPOST

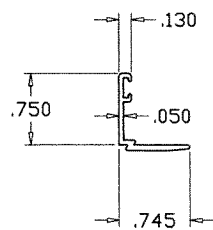

GLAZING BEAD

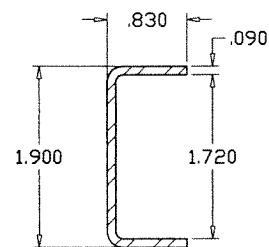

REINFORCING CHANNEL
36 KSI STEEL

ITEM	PART #	QUANTITY	DESCRIPTION	MATERIAL	MANF./SUPPLIER/REMARKS
1	FWS-009	4	FRAME	6063-T6	-
2	FWS-011	4	VENT	6063-T6	-
3	FWS-010	1	CENTER POST	6063-T6	-
4	FWG-008	AS REQD.	GLAZING BEAD	6063-T5	-
5	-	AS REQD.	FRAME ASSEMBLY SCREWS	ST. STEEL	#10 X 3/4" PH SMS
6	-	AS REQD.	VENT ASSEMBLY SCREWS	ST. STEEL	#10 X 1-1/2" PH SMS
7	E102	AS REQD.	FRAME WEATHERSTRIPPING (.078 X .300)	VINYL	ULTRAFAB
8	E206	AS REQD.	VENT WEATHERSTRIPPING (.187 X .350)	VINYL	ULTRAFAB
9	34,12,00,100	2/ VENT	4 BAR HINGE, AT TOP AND BOTTOM	STEEL	TRUTH, ATTACHED W/ (6) #8 X 3/8" SS SMS
10	30066	2/ VENT	LEVER TYPE FACE MOUNT LOCK	STEEL	TRUTH, AT 12" FROM TOP AND BOTTOM
11	21087	2/ VENT	LOCK KEEPERS, AT FRAME JAMB FACING LOCK	STEEL	ATTACHED W/ (2) #10 X 3/8" SS SMS
12	40066	1	ROTO OPERATOR	STEEL	TRUTH, ATTACHED W/ (4) #8 X 3/8" SS SMS
13	-	-	.057 THICK CORNER KEY	ST. STEEL	1-1/2" X 1-1/2" X 1/2"
14	-	2/ LOCK	LOCK INSTALLATION SCREWS	-	#12 X 1/2" PH SMS
15	-	AS REQD.	CENTER POST REINFORCING	STEEL	-
16	-	2/ LITE	SETTING BLOCKS AT 1/4 POINTS	EPDM	DUROMETER 80±5 SHORE A

PRODUCT RENEWED
as complying with the Florida
Building Code
NOA-No. 24-0417.01
Expiration Date: 06/27/2025
By: *Manuel Perez*
Miami-Dade Product Control

PRODUCT REVISED
As complying with the Florida
Building Code
NOA-No. 23-0928.26
Expiration Date: 06/27/2024
By: *Manuel Perez*
Miami-Dade Product Control

JUL 19 2023

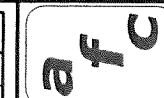
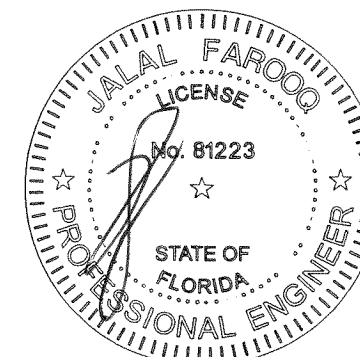

AL-FAROOQ CORPORATION
ENGINEERS & PRODUCT DEVELOPMENT
9360 SUNSET DRIVE, SUITE 220
MIAMI, FLORIDA 33173 (C.A.N. 3538)
TEL. (305) 264-8100 FAX. (305) 262-6978

ALUM OUTSWING CASEMENT WINDOW (L.M.I.)

FLORIDA WINDOW SYSTEMS CORP.
7191 N.W. 77 TERRACE
MEDLEY, FL. 33166
TEL. (305) 805-9420 FAX (305) 805-9424

no	date	by	description
E	09.11.14		UPDATED TO 2014 FBC
F	05.10.19		UPDATED TO 2017 FBC
G	11.05.20		UPDATED TO 2020 FBC
H	07.13.23		NO CHANGE THIS SHEET

date: 05-28-03
scale: 1/2" = 1"
dr. by: TARIQ
chk. by:

drawing no.

W03-36

sheet 5 of 6

COMP-ANL\W03-36FWS

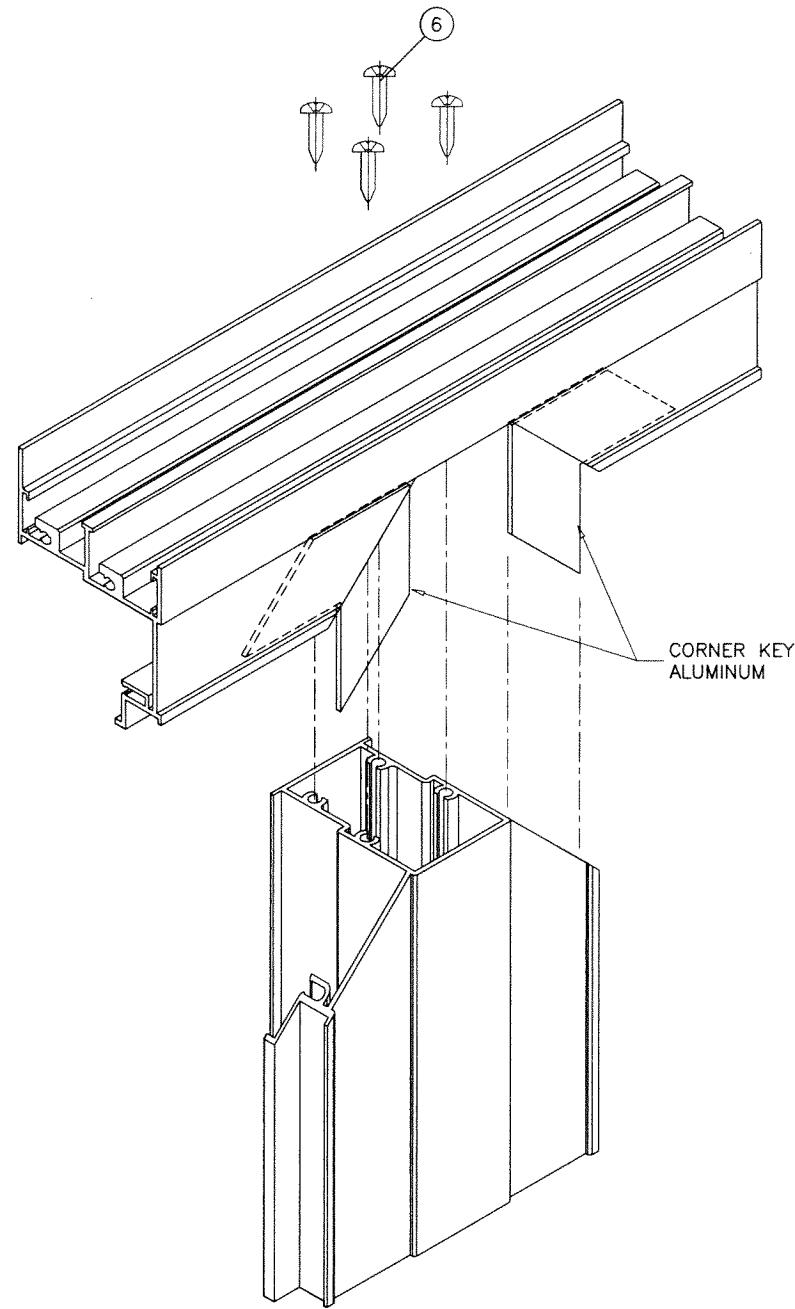

IMPOST CORNER

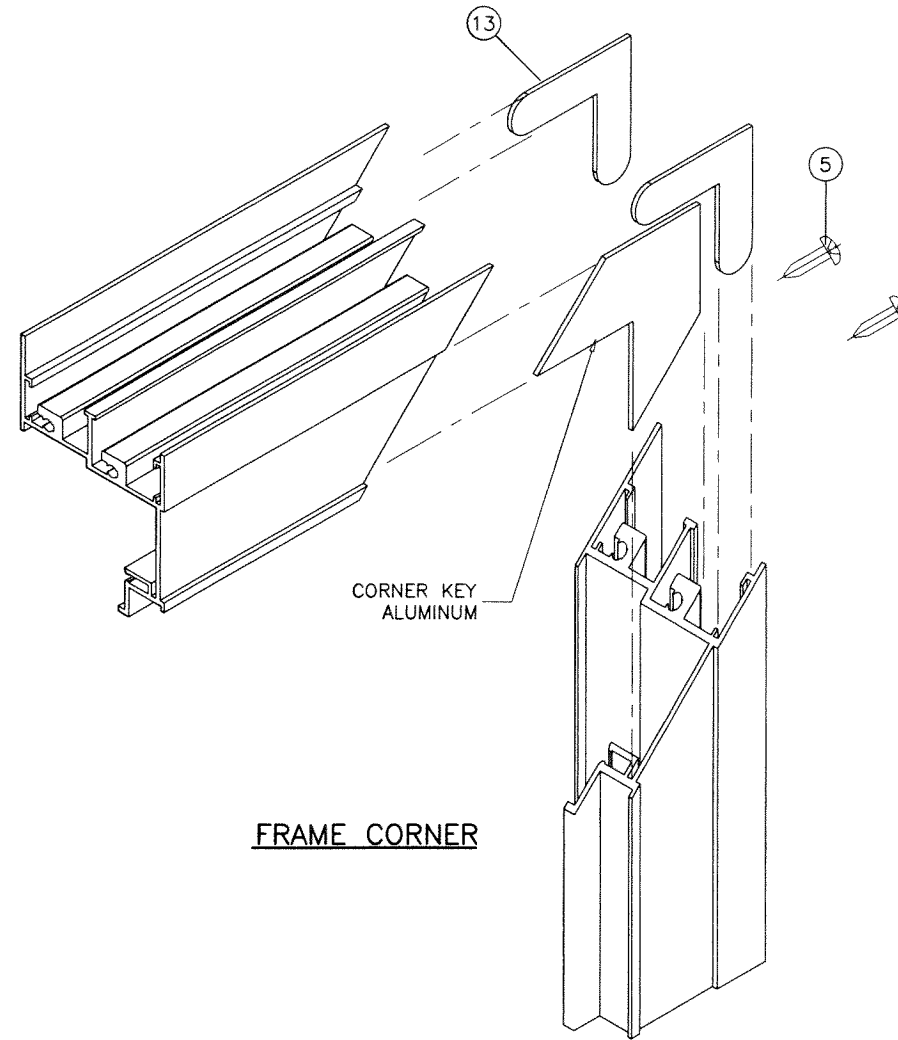

FRAME CORNER

ALL FRAME AND VENT CORNERS TO BE SEALED WITH WHITE/ALUM COLORED SEALANT.

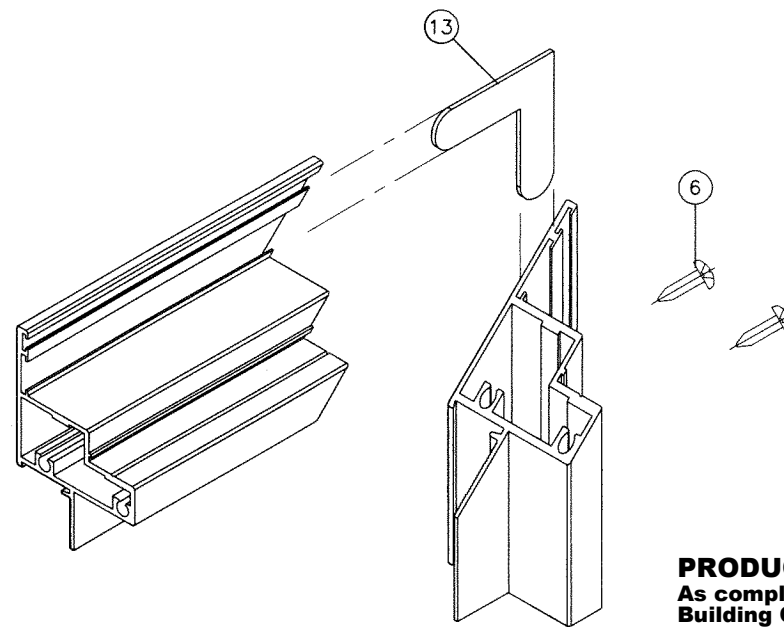

VENT CORNER

PRODUCT REVISED
 As complying with the Florida Building Code
 NOA-No. **23-0928.26**
 Expiration Date: **06/27/2024**
 By: *Manuel Perez*
 Miami-Dade Product Control

JUL 19 2023

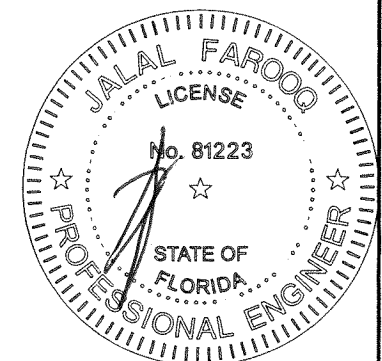

af c
AL-FAROOQ CORPORATION
 ENGINEERS & PRODUCT DEVELOPMENT
 9360 SUNSET DRIVE, SUITE 220
 MIAMI, FLORIDA 33173 (C.A.N. 3538)
 TEL. (305) 264-8100 FAX. (305) 262-6978
 COMP-ANL\W03-36FWS

ALUM OUTSWING CASEMENT WINDOW (L.M.I.)
FLORIDA WINDOW SYSTEMS CORP.
 7191 N.W. 77 TERRACE
 MEDLEY, FL. 33166
 TEL. (305) 805-9420 FAX (305) 805-9424

no	date	by	description
E	09.11.14		NO CHANGE THIS SHEET
F	05.10.19		UPDATED TO 2017 FBC
G	11.05.20		UPDATED TO 2020 FBC
H	07.13.23		NO CHANGE THIS SHEET

date: 05-28-03
 scale: 1/2" = 1"
 dr. by: TARIQ
 chk. by:

drawing no.
W03-36
 sheet 6 of 6