



MIAMI-DADE COUNTY
PRODUCT CONTROL SECTION
 11805 SW 26 Street, Room 208
 Miami, Florida 33175-2474
 T (786) 315-2590 F (786) 315-2599
www.miamidade.gov/building

DEPARTMENT OF REGULATORY AND ECONOMIC RESOURCES (RER)
 BOARD AND CODE ADMINISTRATION DIVISION
NOTICE OF ACCEPTANCE (NOA)

E.S. Windows, LLC
 3550 NW 49th Street
 Miami, FL 33142

SCOPE:

This NOA is being issued under the applicable rules and regulations governing the use of construction materials. The documentation submitted has been reviewed and accepted by Miami-Dade County RER-Product Control Section to be used in Miami-Dade County and other areas where allowed by the Authority Having Jurisdiction (AHJ).

This NOA shall not be valid after the expiration date stated below. The Miami-Dade County Product Control Section (In Miami-Dade County) and/ or the AHJ (in areas other than Miami-Dade County) reserve the right to have this product or material tested for quality assurance purposes. If this product or material fails to perform in the accepted manner, the manufacturer will incur the expense of such testing and the AHJ may immediately revoke, modify, or suspend the use of such product or material within their jurisdiction. RER reserves the right to revoke this acceptance, if it is determined by Miami-Dade County Product Control Section that this product or material fails to meet the requirements of the applicable building code.

This product is approved as described herein and has been designed to comply with the Florida Building Code, including the High Velocity Hurricane Zone.

DESCRIPTION: Series “ES-H340 Thermal” Aluminum Single Hung Window – L.M.I.

APPROVAL DOCUMENT: Drawing No. **W14-39** titled “ES-H340 Thermal Alum Single Hung Wdw. (LMI)”, sheets 1, 1.1, 1.2, 2, 2.1, 3, 3.1, 4, 6, 7, 8, 8.1, 9, 10 and 11 of 11, dated 10/10/14, with revision C dated 03/06/24, prepared by Al-Farooq Corporation, signed and sealed by Jalal Farooq, P.E., bearing the Miami-Dade County Product Control Revision stamp with the Notice of Acceptance number and expiration date by the Miami-Dade County Product Control Section.

MISSILE IMPACT RATING: Large and Small Missile Impact Resistant

LABELING: Each unit shall bear a permanent label with the manufacturer's name or logo, **Barranquilla, Colombia**, model/series, and following statement: "Miami-Dade County Product Control Approved", unless otherwise noted herein.

RENEWAL of this NOA shall be considered after a renewal application has been filed and there has been no change in the applicable building code negatively affecting the performance of this product.

TERMINATION of this NOA will occur after the expiration date or if there has been a revision or change in the materials, use, and/ or manufacture of the product or process. Misuse of this NOA as an endorsement of any product, for sales, advertising or any other purposes shall automatically terminate this NOA. Failure to comply with any section of this NOA shall be cause for termination and removal of NOA.

ADVERTISEMENT: The NOA number preceded by the words Miami-Dade County, Florida, and followed by the expiration date may be displayed in advertising literature. If any portion of the NOA is displayed, then it shall be done in its entirety.

INSPECTION: A copy of this entire NOA shall be provided to the user by the manufacturer or its distributors and shall be available for inspection at the job site at the request of the Building Official.

This NOA **revises NOA No. 20-0310.13** and consists of this page 1 and evidence pages E-1, E-2, E-3 and E-4, as well as approval document mentioned above.

The submitted documentation was reviewed by **Manuel Perez, P.E.**

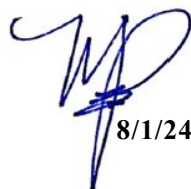

 8/1/24

NOA No. 24-0425.01
Expiration Date: June 25, 2025
Approval Date: August 15, 2024
 Page 1

NOTICE OF ACCEPTANCE: EVIDENCE SUBMITTED

1. EVIDENCE SUBMITTED UNDER PREVIOUS NOA's

A. DRAWINGS

1. Manufacturer's die drawings and sections.
(Submitted under NOA No. 15-0129.12)
2. Drawing No. **W14-39**, titled "ES-H340 Thermal Alum Single Hung Wdw. (L.M.I.)", sheets 1 through 11 of 11, dated 10/10/14, with revision **B** dated 11/01/17, prepared by Al-Farooq Corporation, signed and sealed by Javad Ahmad, P.E.
(Submitted under NOA No. 17-1218.10)

B. TESTS

1. Test reports on: 1) Air Infiltration Test, per FBC, TAS 202-94
2) Uniform Static Air Pressure Test, Loading per FBC TAS 202-94
3) Water Resistance Test, per FBC, TAS 202-94
4) Large Missile Impact Test per FBC, TAS 201-94
5) Cyclic Wind Pressure Loading per FBC, TAS 203-94
6) Forced Entry Test, per AAMA 1303-05 and TAS 202-94
along with marked-up drawings and installation diagram of series ES-H340 aluminum single hung window, prepared by Blackwater Testing, Inc. Test Report No. **BT-ESW-17-006**, dated 08/01/17, signed and sealed by Constantin Bortes, P.E.
(Submitted under NOA No. 17-1218.10)
2. Test reports on: 1) Air Infiltration Test, per FBC, TAS 202-94
2) Uniform Static Air Pressure Test, Loading per FBC TAS 202-94
3) Water Resistance Test, per FBC, TAS 202-94
4) Large Missile Impact Test per FBC, TAS 201-94
5) Small Missile Impact Test per FBC, TAS 201-94
6) Cyclic Wind Pressure Loading per FBC, TAS 203-94
7) Forced Entry Test, per FBC 2411.3.2.1 (b) and TAS 202-94
along with marked-up drawings and installation diagram of series ES-H340 aluminum single hung window, prepared by Fenestration Testing Laboratory, Inc. Test Report No. **FTL-7607**, dated 06/12/14, signed and sealed by Idalmis Ortega, P.E.
(Submitted under NOA No. 15-0129.12)

C. CALCULATIONS

1. Anchor verification calculations and structural analysis, complying with **FBC 6th Edition (2017)**, dated 10/26/17, prepared by Al-Farooq Corporation, signed and sealed by Javad Ahmad, P.E.
(Submitted under NOA No. 17-1218.10)
2. Glazing complies with **ASTM E1300-09**



Manuel Pérez, P.E.
Product Control Examiner
NOA No. 24-0425.01
Expiration Date: June 25, 2025
Approval Date: August 15, 2024

E.S. Windows, LLC

NOTICE OF ACCEPTANCE: EVIDENCE SUBMITTED

1. EVIDENCE SUBMITTED UNDER PREVIOUS NOA's (CONTINUED)

D. QUALITY ASSURANCE

1. Miami-Dade Department of Regulatory and Economic Resources (RER).

E. MATERIAL CERTIFICATIONS

1. Notice of Acceptance No. **19-0305.02** issued to **Kuraray America, Inc.** for their “**Trosifol® Ultraclear, Clear and Color PVB Glass Interlayers**” dated 05/09/19, expiring on 07/08/24.
2. Notice of Acceptance No. **17-0808.02** issued to **Kuraray America, Inc.** for their “**SentryGlas® (Clear and White) Glass Interlayers**” dated 12/28/17, expiring on 07/04/23.

F. STATEMENTS

1. Statement letter of conformance, complying with **FBC 6th Edition (2017)**, dated February 20, 2017, issued by Al-Farooq Corporation, signed and sealed by Javad Ahmad, P.E.
(Submitted under NOA No. 20-0310.13)
2. Distributor Agreement, dated 10/20/10, signed by Carla Garcia Torrente and by Andres Chamorro.
(Submitted under NOA No. 12-0308.38)
3. Laboratory compliance letter for Test Reports No. **FTL-5686** and **FTL-5811**, issued by Fenestration Testing Laboratory, Inc., dated 12/30/08 and 02/16/09, signed and sealed by Carlos S. Rionda, P.E. and sealed by Michael R. Wenzel, P.E. respectively.
(Submitted under NOA No. 09-1008.04)
4. Laboratory compliance letter for Test Reports No. **HETI-04-1412**, **HETI-05-1937** and **HETI-05-1423**, issued by Hurricane Engineering and Testing, Inc., dated 10/13/04, 01/26/05 and 01/12/05, all signed and sealed by Ivonne Ghia, P.E.
(Submitted under NOA's No. 04-1208.02 and 05-0303.02)

G. OTHERS

1. Notice of Acceptance No. **17-1218.10**, issued to ES Windows LLC, for their Series “**ES-H340 Thermal**” Aluminum Single Hung Window – L.M.I., approved on 02/22/18 and expiring on 06/25/20.

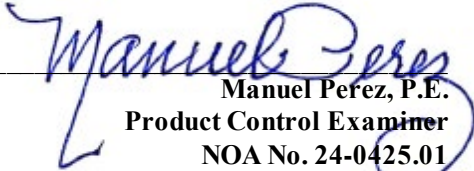
Manuel Perez, P.E.
Product Control Examiner
NOA No. 24-0425.01
Expiration Date: June 25, 2025
Approval Date: August 15, 2024

NOTICE OF ACCEPTANCE: EVIDENCE SUBMITTED

2. NEW EVIDENCE SUBMITTED

A. DRAWINGS

1. Drawing No. **W14-39**, titled “ES-H340 Thermal Alum Single Hung Wdw. (L.M.I.)”, sheets 1, 1.1, 1.2, 2, 2.1, 3, 3.1, 4, 6, 7, 8, 8.1, 9, 10 and 11 of 11, dated 10/10/14, with revision **C** dated 03/06/24, prepared by Al-Farooq Corporation, signed and sealed by Jalal Farooq, P.E.

B. TESTS

1. Test reports on: 1) Air Infiltration Test, per FBC, TAS 202-94
2) Uniform Static Air Pressure Test, Loading per FBC TAS 202-94
3) Water Resistance Test, per FBC, TAS 202-94
4) Large Missile Impact Test per FBC, TAS 201-94
5) Cyclic Wind Pressure Loading per FBC, TAS 203-94
along with marked-up drawings and installation diagram of series ES-H340 aluminum single hung window, prepared by FTL, a QAI Company, Test Report No. **FTL-12521**, dated 06/03/21, signed and sealed by Idalmis Ortega, P.E.
2. Test reports on: 1) Air Infiltration Test, per FBC, TAS 202-94
2) Uniform Static Air Pressure Test, Loading per FBC TAS 202-94
3) Water Resistance Test, per FBC, TAS 202-94
4) Large Missile Impact Test per FBC, TAS 201-94
5) Cyclic Wind Pressure Loading per FBC, TAS 203-94
6) Forced Entry Test, per AAMA 1303-05 and TAS 202-94
along with marked-up drawings and installation diagram of series ES-H340 aluminum single hung window, prepared by FTL, a QAI Company, Test Report No. **FTL-10828**, dated 02/03/20, signed and sealed by Idalmis Ortega, P.E.

C. CALCULATIONS

1. Anchor verification calculations and structural analysis, complying with FBC 8th Edition (2023), dated 04/16/24, prepared by Al-Farooq Corporation, signed and sealed by Jalal Farooq, P.E.
2. Glazing complies with **ASTM E1300-09**

D. QUALITY ASSURANCE

1. Miami-Dade Department of Regulatory and Economic Resources (RER)

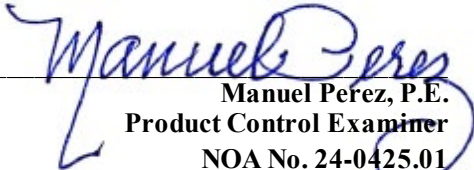
Manuel Perez, P.E.
Product Control Examiner
NOA No. 24-0425.01
Expiration Date: June 25, 2025
Approval Date: August 15, 2024

NOTICE OF ACCEPTANCE: EVIDENCE SUBMITTED

2. NEW EVIDENCE SUBMITTED (CONTINUED)

E. MATERIAL CERTIFICATIONS

1. Notice of Acceptance No. **24-0205.08** issued to **Kuraray America, Inc.** for their “**Trosifol® Ultraclear, Clear and Color PVB Glass Interlayers**” dated 03/21/24, expiring on 07/08/29.
2. Notice of Acceptance No. **23-0717.30** issued to **Kuraray America, Inc.** for their “**SentryGlas® (Clear and White) Glass Interlayers**” dated 08/31/23, expiring on 07/04/28.

F. STATEMENTS

1. Statement letter of conformance, complying with **FBC 8th Edition (2023)**, dated April 16, 2024, issued by Al-Farooq Corporation, signed and sealed by Jalal Farooq, P.E.
2. Proposal No. **24-0104** issued by the Product Control Section, dated March 01, 2024, signed by Manuel Perez, P.E.
3. Proposal No. **19-0053** issued by the Product Control Section, dated March 25, 2019, signed by Manuel Perez, P.E.

G. OTHERS

1. Notice of Acceptance No. **20-0310.13**, issued to ES Windows LLC, for their Series “**ES-H340 Thermal**” Aluminum Single Hung Window – L.M.I., approved on 04/23/20 and expiring on 06/25/25.

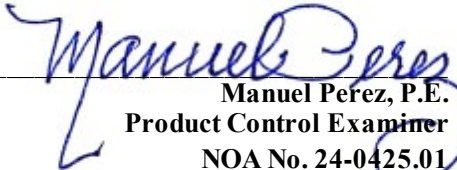
Manuel Perez, P.E.
Product Control Examiner
NOA No. 24-0425.01
Expiration Date: June 25, 2025
Approval Date: August 15, 2024

ES-H340 (L.M.I.)

THERMAL ALUMINUM SINGLE HUNG WINDOW

DESIGN LOAD RATINGS FOR THESE WINDOWS TO BE AS PER CHARTS SHOWN ON SHEETS 3 & 3.1.

NOA APPLIES TO SINGLE UNITS OR SIDE BY SIDE COMBINATIONS OF S.H./S.H. OR SINGLE HUNG WITH OTHER WINDOW TYPES IN MODULES OF TWO OR MORE WINDOWS USING MIAMI-DADE COUNTY APPROVED MULLIONS IN BETWEEN. LOWER DESIGN PRESSURE FROM WINDOWS OR MULLION NOA WILL APPLY TO ENTIRE SYSTEM.

THIS PRODUCT HAS BEEN DESIGNED AND TESTED TO COMPLY WITH THE REQUIREMENTS OF THE 2023 (8TH EDITION) FLORIDA BUILDING CODE INCLUDING HIGH VELOCITY HURRICANE ZONE (HVHZ).

1BY OR 2BY WOOD BUCKS & BUCK FASTENERS BY OTHERS, MUST BE DESIGNED AND INSTALLED ADEQUATELY TO TRANSFER APPLIED PRODUCT LOADS TO THE BUILDING STRUCTURE.

ANCHORS SHALL BE CORROSION RESISTANT, SPACED AS SHOWN ON DETAILS AND INSTALLED PER MANUF'S INSTRUCTIONS. SPECIFIED EMBEDMENT TO BASE MATERIAL SHALL BE BEYOND WALL DRESSING OR STUCCO.

A LOAD DURATION INCREASE IS USED IN DESIGN OF ANCHORS INTO WOOD ONLY.

ALL SHIMS TO BE HIGH IMPACT, NON-METALLIC AND NON-COMPRESSIBLE.

MATERIALS INCLUDING BUT NOT LIMITED TO STEEL/METAL SCREWS, THAT COME INTO CONTACT WITH OTHER DISSIMILAR MATERIALS SHALL MEET THE REQUIREMENTS OF THE 2023 FLORIDA BLDG. CODE & ADOPTED STANDARDS.

THIS PRODUCT NOA IS GENERIC AND DOES NOT PROVIDE INFORMATION FOR A SITE SPECIFIC PROJECT, i.e. LIFE SAFETY OF THIS PRODUCT, ADEQUACY OF STRUCTURE RECEIVING THIS PRODUCT AND SEALING AROUND OPENING FOR WATER INFILTRATION RESISTANCE ETC.

CONDITIONS NOT SHOWN IN THIS DRAWING ARE TO BE ANALYZED SEPARATELY, AND TO BE REVIEWED BY BUILDING OFFICIAL.

DESIGN LOADS SHOWN ARE BASED ON 'ALLOWABLE STRESS DESIGN (ASD)'.

THESE WINDOWS ARE RATED FOR LARGE & SMALL MISSILE IMPACT. SHUTTERS ARE NOT REQUIRED.

PRODUCT REVISED
As complying with the Florida Building Code

NOA-No. **24-0425.01**

Expiration Date: **06/25/2025**

By: *Manuel Fern*

Miami-Dade Product Control

APR 23 2024

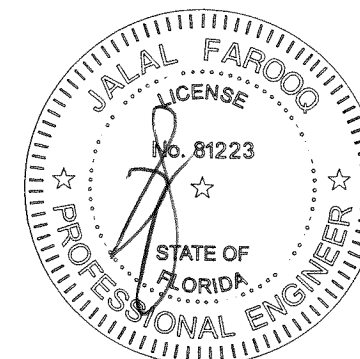

af c

AL-FAROOQ CORPORATION
ENGINEERS & PRODUCT DEVELOPMENT
9360 SUNSET DRIVE, SUITE 220
MIAMI, FLORIDA 33173 (C.A.N. 3538)
TEL. (305) 264-8100 FAX. (305) 262-6978
COMP - ANL \ W14 - 39 - ESW

ES-H340 THERMAL ALUM SINGLE HUNG WDW. (L.M.I.)

E.S. WINDOWS, LLC
3550 N.W. 49 STREET
MIAMI, FL. 33142
TEL. (305) 638-5151 FAX. (305) 638-5158

no	date	by	description
A	05.21.15		REV. PER RER COMMENTS
B	11.01.17		GENERAL REVISION
C	03.06.24		GENERAL REVISION

revisions:

date: 10-10-14
scale: 1/2"=1'-0"
dr. by: TARIQ
chk. by:

drawing no.
W14-39

sheet 1 of 11

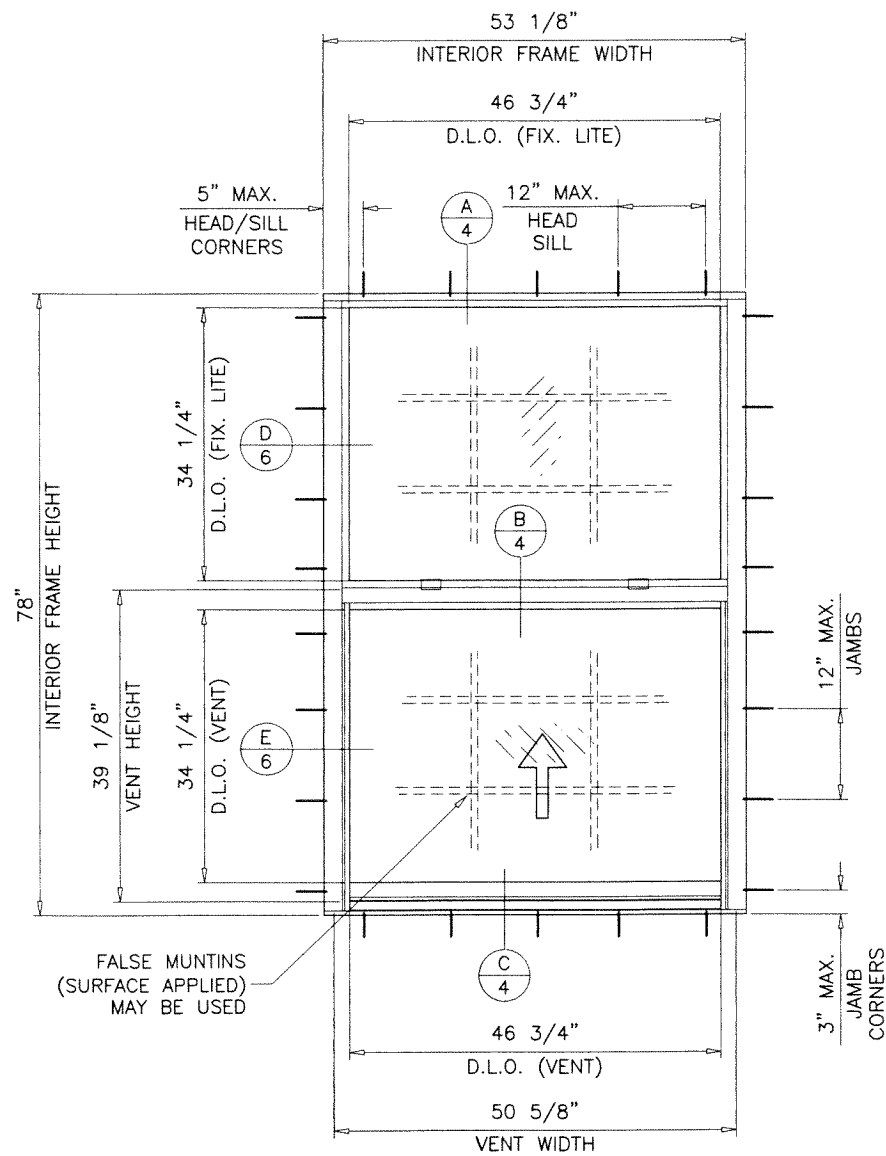

TYPICAL ELEVATION
EQUAL LITES
FLUSH FRAMES

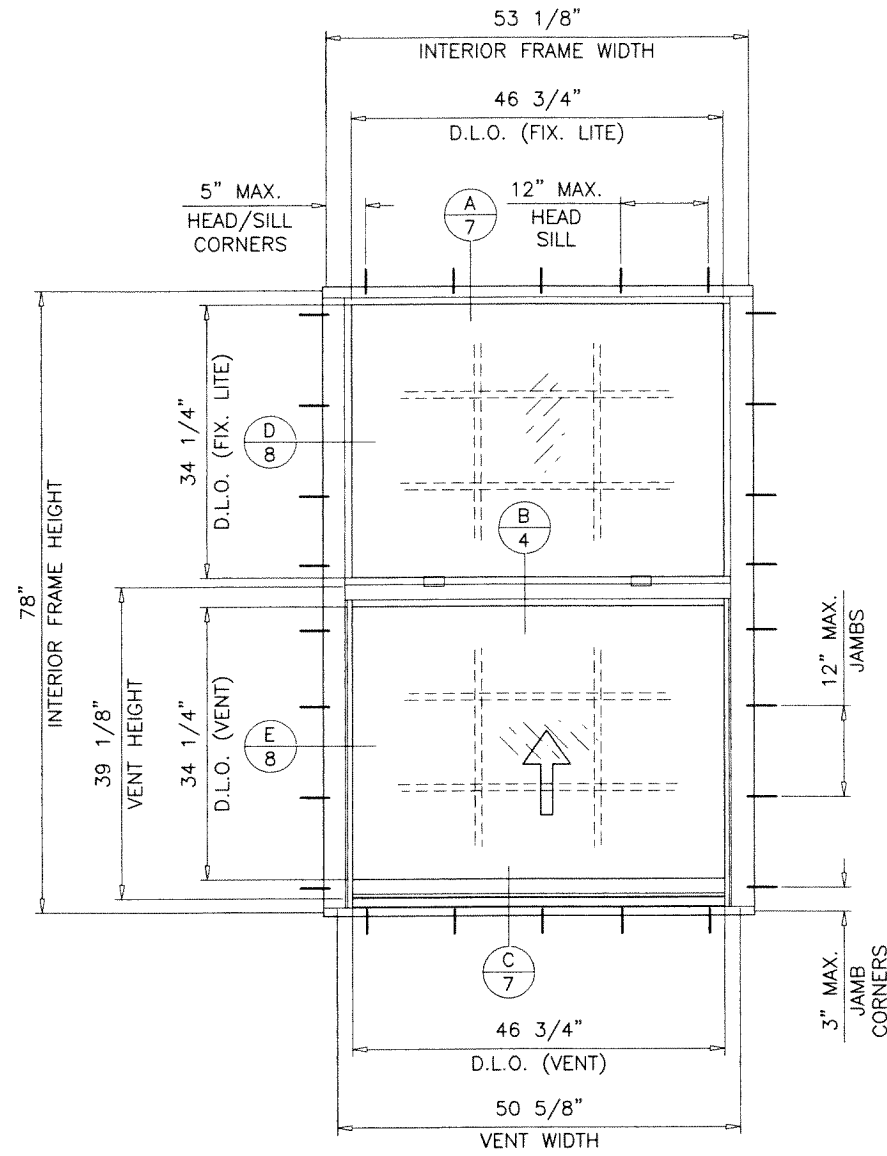

TYPICAL ELEVATION
EQUAL LITES
FLANGE FRAMES

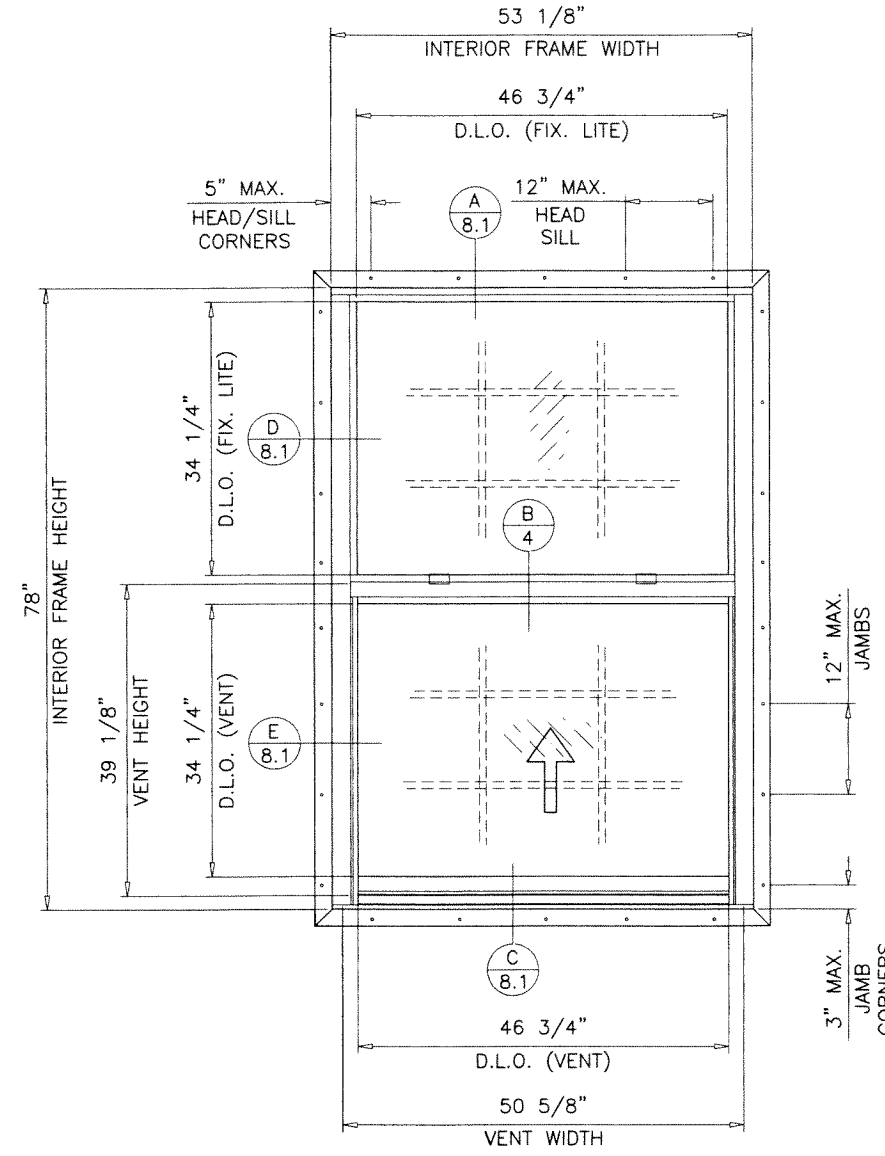

TYPICAL ELEVATION
EQUAL LITES
FLUSH FRAMES WITH FINS

NOTE:
FOR FLUSH FRAME WINDOWS WITH NAIL FINS
LIMIT MAX. DESIGN LOADS TO
+70.0, -75.0 PSF

PRODUCT REVISED
As complying with the Florida
Building Code
NOA-No. **24-0425.01**
Expiration Date: **06/25/2025**
By: *Manuel Fern*
Miami-Dade Product Control

APR 23 2024

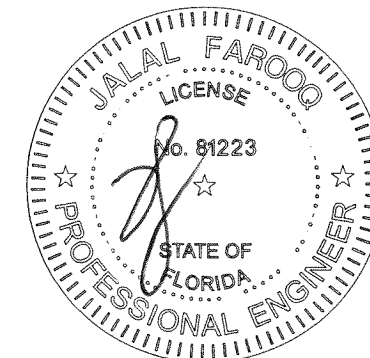

af c
AL-FAROOQ CORPORATION
ENGINEERS & PRODUCT DEVELOPMENT
9360 SUNSET DRIVE, SUITE 220
MIAMI, FLORIDA 33173 (C.A.N. 3538)
TEL. (305) 264-8100 FAX. (305) 262-6978
COMP-ANL\W14-39-ESW

ES-H340 THERMAL ALUM SINGLE HUNG WDW. (L.M.I.)
E.S. WINDOWS, LLC
3550 N.W. 49 STREET
MIAMI, FL. 33142
TEL. (305) 638-5151 FAX. (305) 638-5158

no	date	by	description
C	03.06.24		GENERAL REVISION

date: 10-10-14
scale: 1/2" = 1'-0"
dr. by: TARIQ
chk. by:

drawing no.
W14-39
sheet 1.1 of 11

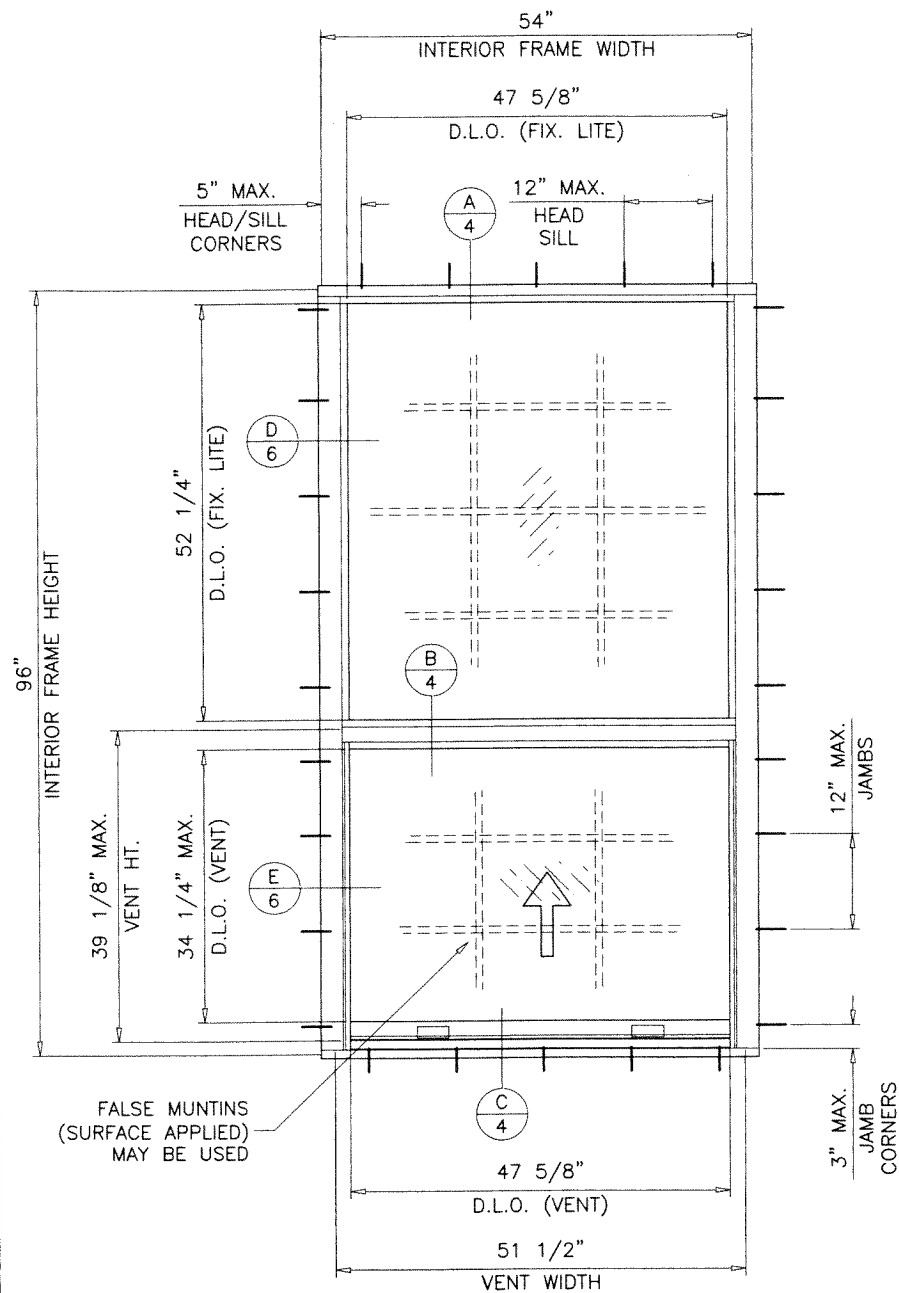

TYPICAL ELEVATION
UNEQUAL LITES (ORIEL TYPES)
FLUSH FRAMES

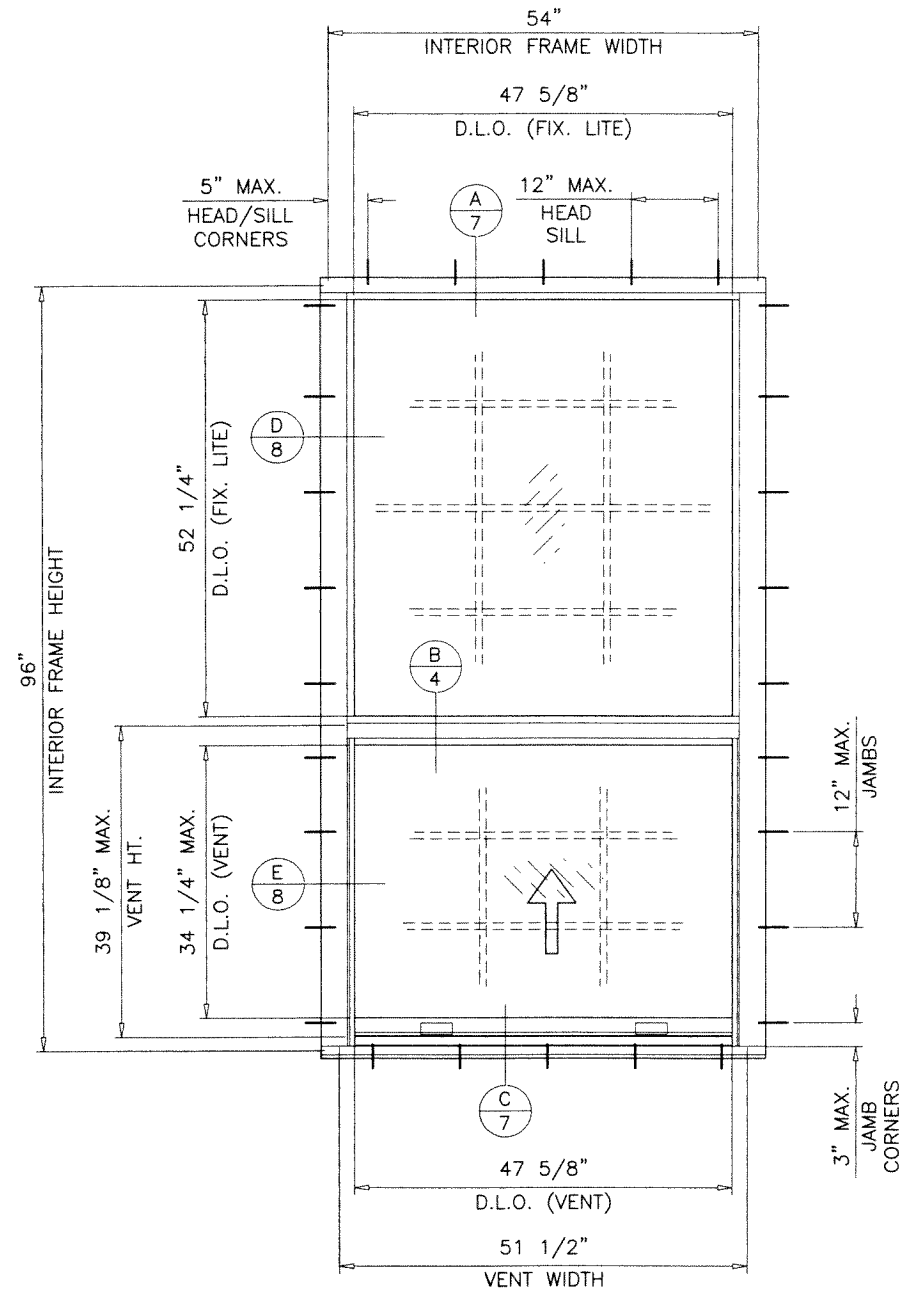

TYPICAL ELEVATION
UNEQUAL LITES (ORIEL TYPES)
FLANGE FRAMES

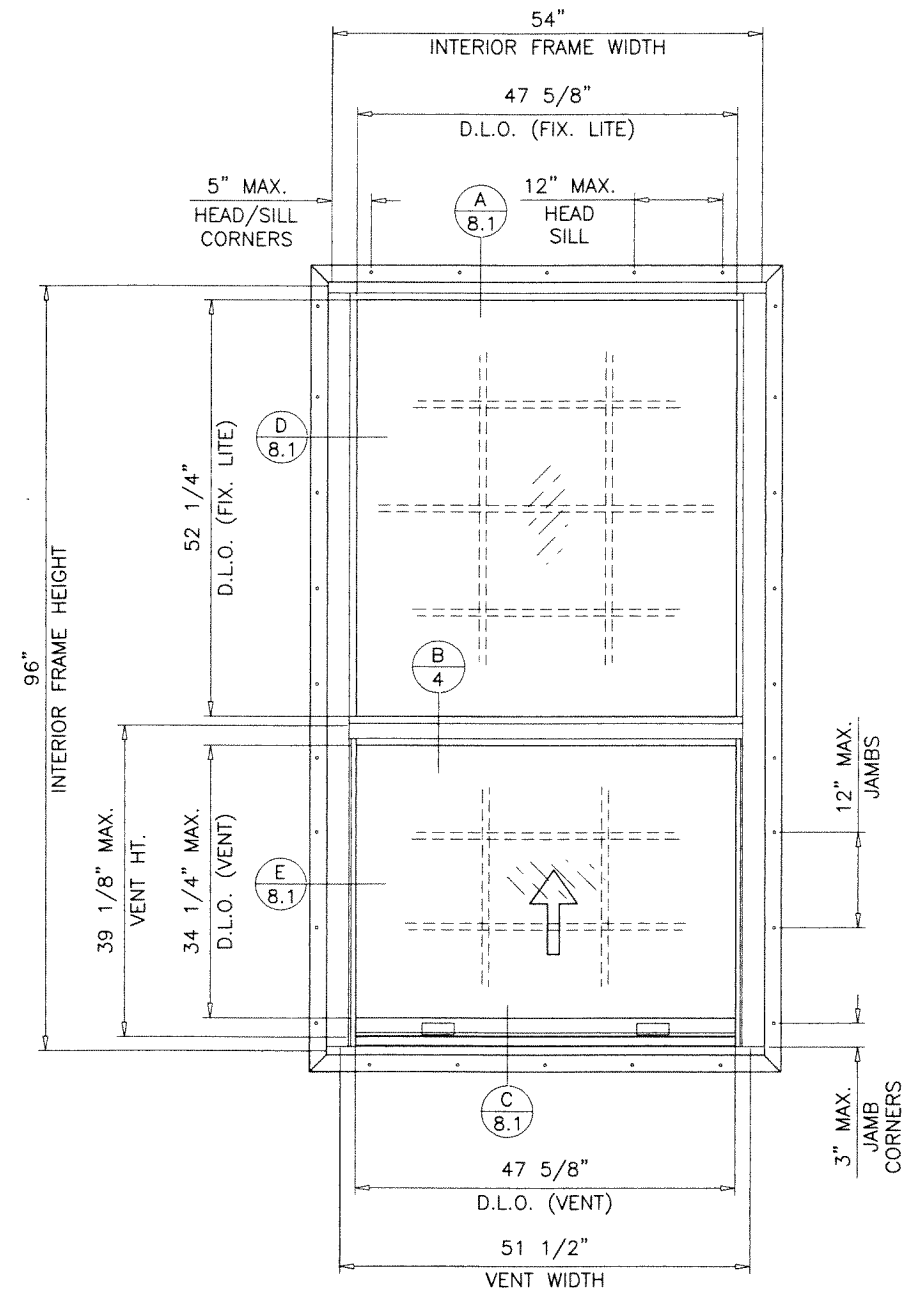

TYPICAL ELEVATION
UNEQUAL LITES (ORIEL TYPES)
FLUSH FRAMES WITH FINs

NOTE:
FOR FLUSH FRAME WINDOWS WITH NAIL FINs
LIMIT MAX. DESIGN LOADS TO
+70.0, -75.0 PSF

PRODUCT REVISED
As complying with the Florida
Building Code
NOA-No. **24-0425.01**
Expiration Date: **06/25/2025**
By: *Manuel Fern*
Miami-Dade Product Control

APR 23 2024

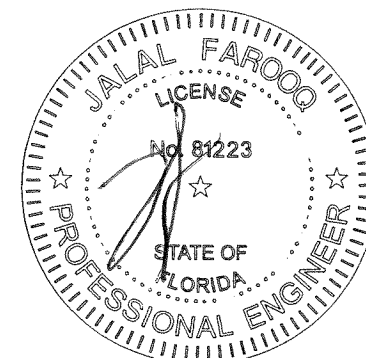

afC
AL-FAROOQ CORPORATION
ENGINEERS & PRODUCT DEVELOPMENT
9360 SUNSET DRIVE, SUITE 220
MIAMI, FLORIDA 33173 (C.A.N. 3538)
TEL. (305) 264-8100 FAX. (305) 262-6978
COMP-ANL\W14-39-ESW

ES-H340 THERMAL ALUM SINGLE HUNG WDW. (L.M.I.)
E.S. WINDOWS, LLC
3550 N.W. 49 STREET
MIAMI, FL. 33142
TEL. (305) 638-5151 FAX. (305) 638-5158

no	date	by	description
C	03.06.24		GENERAL REVISION

date: 10-10-14
scale: 1/2"=1'-0"
dr. by: TARIQ
chk. by:

drawing no.
W14-39
sheet 1.2 of 11

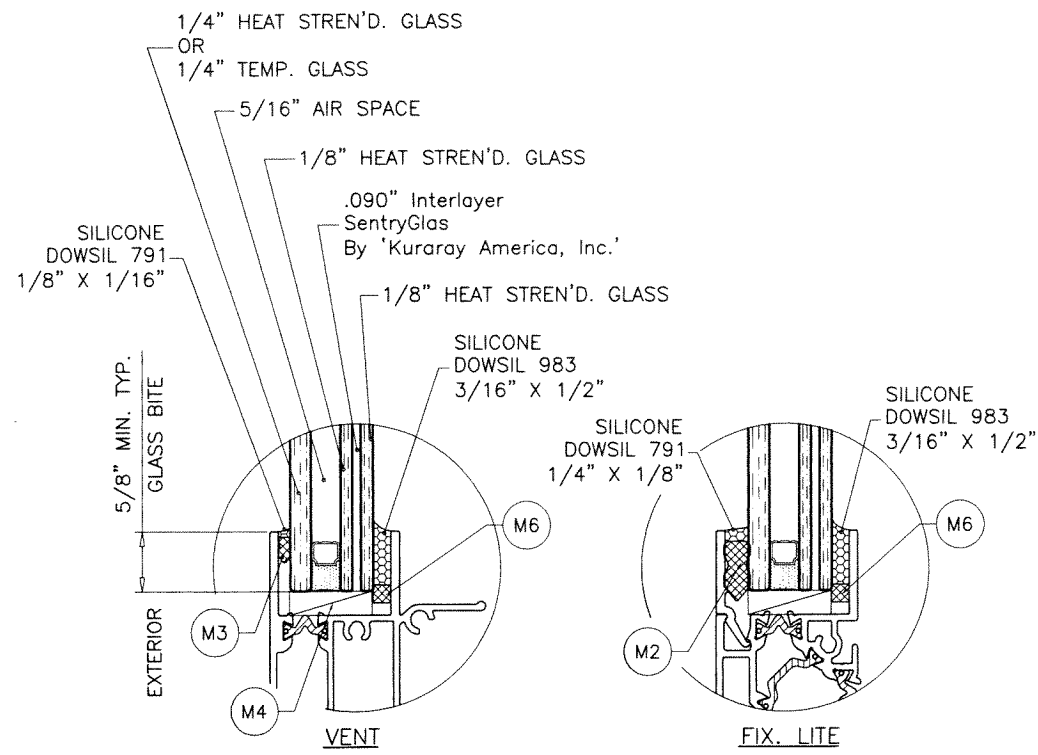

GLASS TYPE 'A'
7/8" OVERALL NOM. THK.

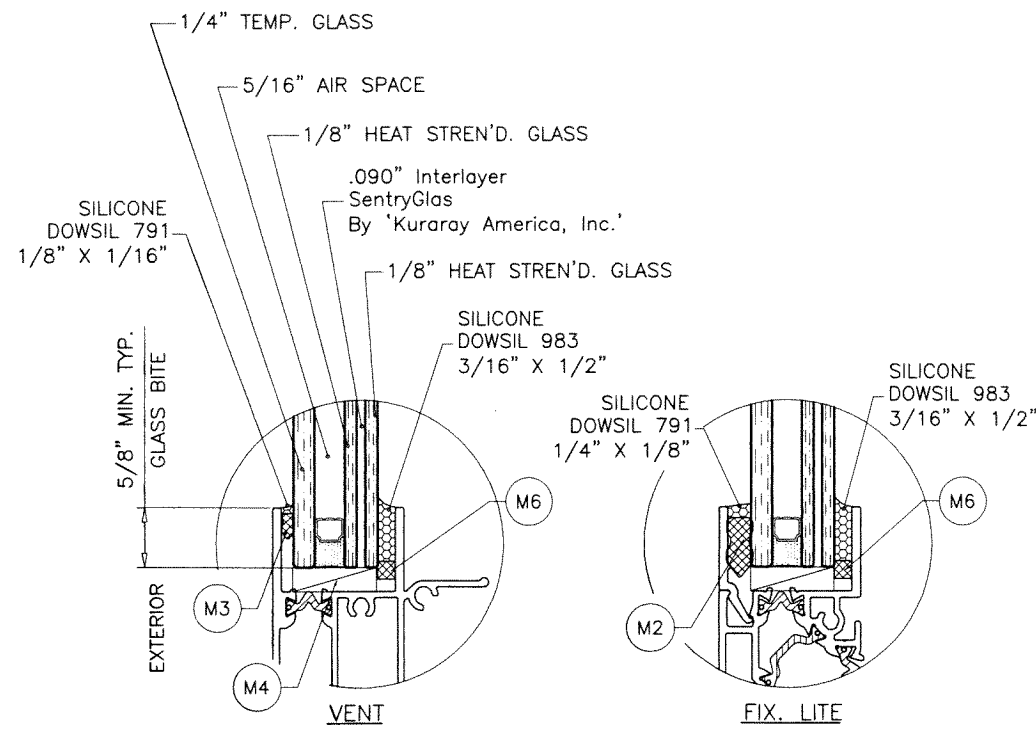

GLASS TYPE 'A1'
7/8" OVERALL NOM. THK.

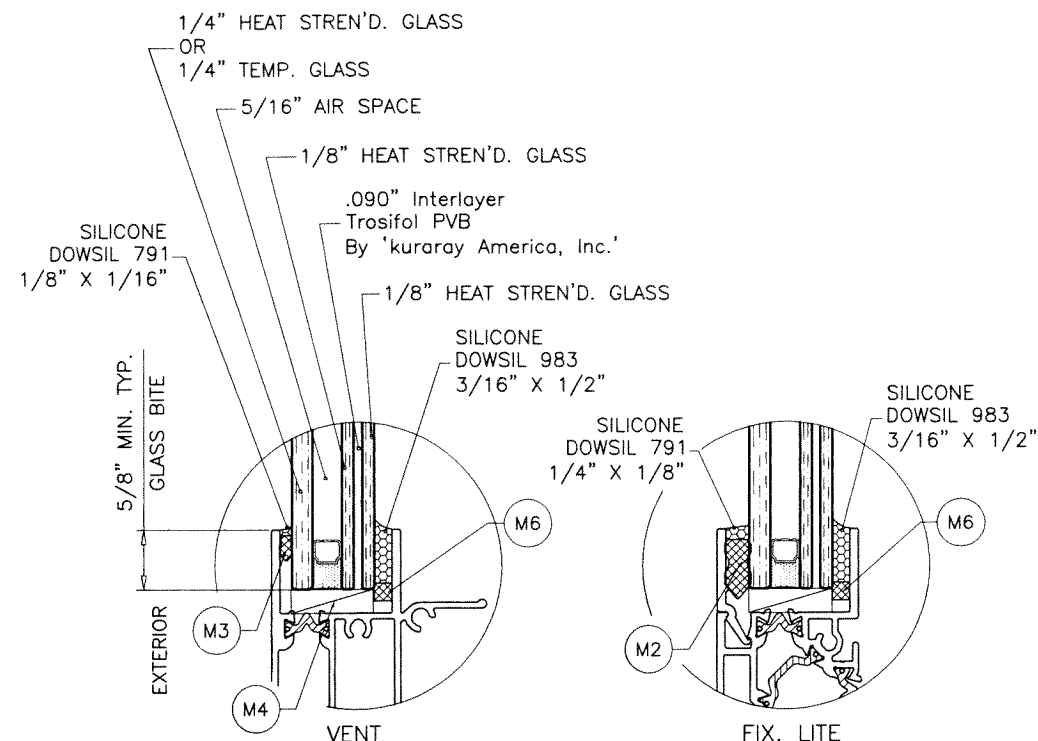

GLASS TYPE 'B'
7/8" OVERALL NOM. THK.

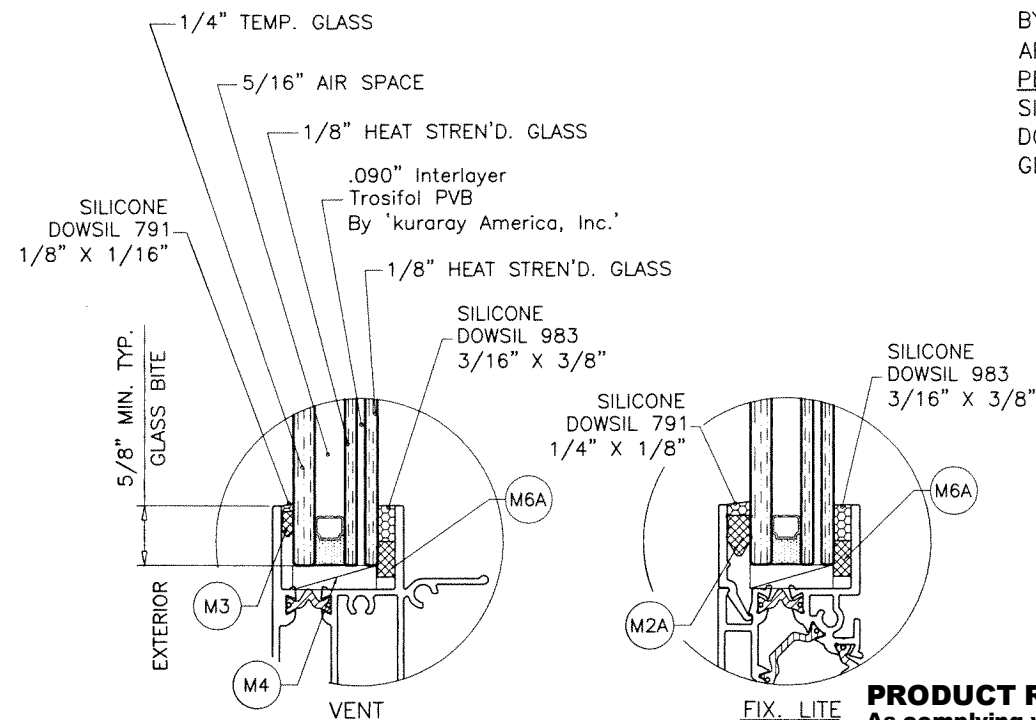

GLASS TYPE 'B1'
7/8" OVERALL NOM. THK.

5/16" AIR SPACE CONSISTING OF:
SPACER:
'HELIMA' LOW PROFILE ALUMINUM SPACER
BY 'LINGERMANN GMBH'
AROUND THE PERIMETER OF THE GLASS.
PERIMETER SEALANT:
SILICONE
DOWSIL 791
GE 2000

GLAZING OPTIONS

NOTE:
TO QUALIFY FOR SMALL MISSILE IMPACT RATING
EXTERIOR PLY OF GLASS TYPES 'A' & 'B' MUST BE TEMPERED.

PRODUCT REVISED
As complying with the Florida
Building Code
NOA-No. **24-0425.01**
Expiration Date: **06/25/2025**
By: *Manuel Perez*
Miami-Dade Product Control
APR 23 2024

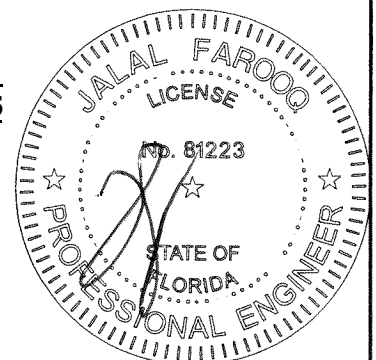

af c
AL-FAROOQ CORPORATION
ENGINEERS & PRODUCT DEVELOPMENT
9360 SUNSET DRIVE, SUITE 220
MIAMI, FLORIDA 33173 (C.A.N. 3538)
TEL. (305) 264-8100 FAX. (305) 262-6978
COMP-ANL W14-39-ESW

ES-H340 THERMAL ALUM SINGLE HUNG WDW. (L.M.I.)
E.S. WINDOWS, LLC
3550 N.W. 49 STREET
MIAMI, FL. 33142
TEL. (305) 638-5151 FAX. (305) 638-5158

no	date	by	description
B	11.01.17		GENERAL REVISION
C	03.06.24		GENERAL REVISION

date:	10-10-14
scale:	1/2" = 1"
dr. by:	TARIQ
chk. by:	

drawing no.	W14-39
sheet	2 of 11

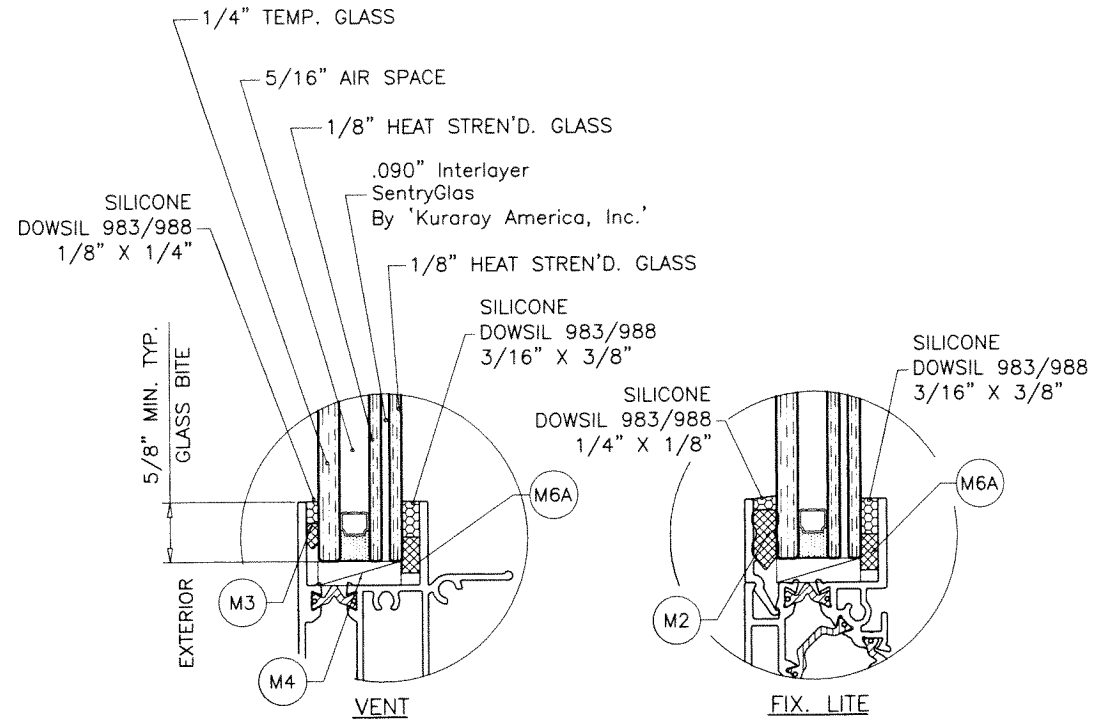

GLASS TYPE 'C'
7/8" OVERALL NOM. THK.

5/16" AIR SPACE CONSISTING OF:

SPACER:

'HELIMA' LOW PROFILE ALUMINUM SPACER
BY 'LINGERMANN GMBH'
AROUND THE PERIMETER OF THE GLASS.

PERIMETER SEALANT:

SILICONE
DOWSIL 791
GE 2000

PRODUCT REVISED

As complying with the Florida
Building Code

NOA-No. **24-0425.01**

Expiration Date: **06/25/2025**

By: *Manuel Ferrer*

Miami-Dade Product Control

APR 23 2024

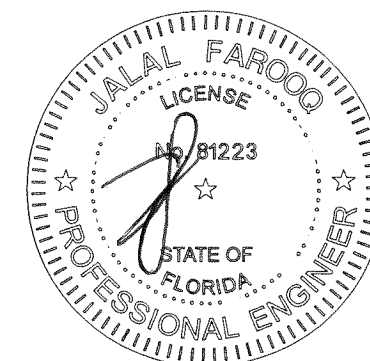

ES-H340 THERMAL ALUM SINGLE HUNG WDW. (L.M.I.)

E.S. WINDOWS, LLC
3550 N.W. 49 STREET
MIAMI, FL. 33142
TEL. (305) 638-5151 FAX. (305) 638-5158

no	date	by	description
C	03.06.24		GENERAL REVISION

date: 10-10-14
scale: 1/2" = 1"
dr. by: TARIQ
chk. by:

drawing no.
W14-39

sheet 2.1 of 11

af c

AL-FAROOQ CORPORATION
ENGINEERS & PRODUCT DEVELOPMENT
9360 SUNSET DRIVE, SUITE 220
MIAMI, FLORIDA 33173 (C.A.N. 3538)
TEL. (305) 264-8100 FAX. (305) 262-6978

COMP-ANL W14-39-ESW

EQUAL LITES WINDOWS DESIGN LOAD CAPACITY - PSF									
INTERIOR FRAME DIMS.		1/4" ANCHORS 1/4" MAX. SHIM				5/16" ANCHORS 1/2" MAX. SHIM		5/16" ANCHORS 1/4" MAX. SHIM	
		GLASS TYPE 'B1'		GLASS TYPES 'A' & 'B'		GLASS TYPE 'A1'		GLASS TYPE 'C'	
WIDTH	HEIGHT	EXT.(+)	INT.(-)	EXT.(+)	INT.(-)	EXT.(+)	INT.(-)	EXT.(+)	INT.(-)
18-1/8"	25" (3)	70.0	75.0	80.0	90.0	80.0	90.0	90.0	160.0
25-1/2"		70.0	75.0	80.0	90.0	80.0	90.0	90.0	160.0
31"		70.0	75.0	80.0	90.0	80.0	90.0	90.0	160.0
36"		70.0	75.0	80.0	90.0	80.0	90.0	90.0	160.0
39"		70.0	75.0	80.0	90.0	80.0	90.0	90.0	160.0
42"		70.0	75.0	80.0	90.0	80.0	90.0	90.0	160.0
43"		70.0	75.0	80.0	90.0	80.0	90.0	90.0	110.0
47"		70.0	75.0	80.0	90.0	80.0	90.0	90.0	110.0
52-1/8"		70.0	75.0	80.0	90.0	80.0	90.0	90.0	110.0
53-1/8"		70.0	75.0	80.0	90.0	80.0	90.0	90.0	110.0
54"	70.0	75.0	80.0	90.0	80.0	90.0	90.0	110.0	
18-1/8"	37-3/8" (4)	70.0	75.0	80.0	90.0	80.0	90.0	90.0	160.0
25-1/2"		70.0	75.0	80.0	90.0	80.0	90.0	90.0	160.0
31"		70.0	75.0	80.0	90.0	80.0	90.0	90.0	160.0
36"		70.0	75.0	80.0	90.0	80.0	90.0	90.0	160.0
39"		70.0	75.0	80.0	90.0	80.0	90.0	90.0	160.0
42"		70.0	75.0	80.0	90.0	80.0	90.0	90.0	160.0
43"		70.0	75.0	80.0	90.0	80.0	90.0	90.0	110.0
47"		70.0	75.0	80.0	90.0	80.0	90.0	90.0	110.0
52-1/8"		70.0	75.0	80.0	90.0	80.0	90.0	90.0	110.0
53-1/8"		70.0	75.0	80.0	90.0	80.0	90.0	90.0	110.0
54"	70.0	75.0	80.0	90.0	80.0	90.0	63.3	110.0	
18-1/8"	49-5/8" (5)	70.0	75.0	80.0	90.0	80.0	90.0	90.0	160.0
25-1/2"		70.0	75.0	80.0	90.0	80.0	90.0	90.0	160.0
31"		70.0	75.0	80.0	90.0	80.0	90.0	90.0	160.0
36"		70.0	75.0	80.0	90.0	80.0	90.0	90.0	160.0
39"		70.0	75.0	80.0	90.0	80.0	90.0	90.0	160.0
42"		70.0	75.0	80.0	90.0	80.0	90.0	90.0	160.0
43"		70.0	75.0	80.0	90.0	80.0	90.0	90.0	110.0
47"		70.0	75.0	80.0	90.0	80.0	90.0	90.0	110.0
52-1/8"		70.0	75.0	80.0	90.0	80.0	90.0	90.0	110.0
53-1/8"		70.0	75.0	80.0	90.0	80.0	90.0	90.0	110.0
54"	70.0	75.0	80.0	90.0	80.0	90.0	90.0	110.0	
18-1/8"	55" (6)	70.0	75.0	80.0	90.0	80.0	90.0	90.0	160.0
25-1/2"		70.0	75.0	80.0	90.0	80.0	90.0	90.0	160.0
31"		70.0	75.0	80.0	90.0	80.0	90.0	90.0	160.0
36"		70.0	75.0	80.0	90.0	80.0	90.0	90.0	160.0
39"		70.0	75.0	80.0	90.0	80.0	90.0	90.0	160.0
42"		70.0	75.0	80.0	90.0	80.0	90.0	90.0	160.0
43"		70.0	75.0	80.0	90.0	80.0	90.0	90.0	110.0
47"		70.0	75.0	80.0	90.0	80.0	90.0	90.0	110.0
52-1/8"		70.0	75.0	80.0	90.0	80.0	90.0	90.0	110.0
53-1/8"		70.0	75.0	80.0	90.0	80.0	90.0	90.0	110.0
54"	70.0	75.0	80.0	90.0	80.0	90.0	90.0	110.0	
18-1/8"	62" (6)	70.0	75.0	80.0	90.0	80.0	90.0	90.0	160.0
25-1/2"		70.0	75.0	80.0	90.0	80.0	90.0	90.0	160.0
31"		70.0	75.0	80.0	90.0	80.0	90.0	90.0	160.0
36"		70.0	75.0	80.0	90.0	80.0	90.0	90.0	160.0
39"		70.0	75.0	80.0	90.0	80.0	90.0	90.0	160.0
42"		70.0	75.0	80.0	90.0	80.0	90.0	90.0	160.0
43"		70.0	75.0	80.0	90.0	80.0	90.0	90.0	110.0
47"		70.0	75.0	80.0	90.0	80.0	90.0	90.0	110.0
52-1/8"		70.0	75.0	80.0	90.0	80.0	90.0	90.0	110.0
53-1/8"		70.0	75.0	80.0	90.0	80.0	90.0	90.0	110.0
54"	70.0	75.0	80.0	90.0	80.0	90.0	90.0	110.0	

EQUAL LITES WINDOWS DESIGN LOAD CAPACITY - PSF									
INTERIOR FRAME DIMS.		1/4" ANCHORS 1/4" MAX. SHIM				5/16" ANCHORS 1/2" MAX. SHIM		5/16" ANCHORS 1/4" MAX. SHIM	
		GLASS TYPE 'B1'		GLASS TYPES 'A' & 'B'		GLASS TYPE 'A1'		GLASS TYPE 'C'	
WIDTH	HEIGHT	EXT.(+)	INT.(-)	EXT.(+)	INT.(-)	EXT.(+)	INT.(-)	EXT.(+)	INT.(-)
18-1/8"	69" (7)	70.0	75.0	80.0	90.0	80.0	90.0	90.0	160.0
25-1/2"		70.0	75.0	80.0	90.0	80.0	90.0	90.0	160.0
31"		70.0	75.0	80.0	90.0	80.0	90.0	90.0	160.0
36"		70.0	75.0	80.0	90.0	80.0	90.0	90.0	160.0
39"		70.0	75.0	80.0	90.0	80.0	90.0	90.0	160.0
42"		70.0	75.0	80.0	90.0	80.0	90.0	90.0	160.0
43"		70.0	75.0	80.0	90.0	80.0	90.0	90.0	110.0
47"		70.0	75.0	80.0	90.0	80.0	90.0	90.0	110.0
52-1/8"		-	-	-	-	80.0	90.0	90.0	110.0
53-1/8"		-	-	-	-	80.0	90.0	90.0	110.0
54"	-	-	-	-	80.0	90.0	90.0	110.0	
18-1/8"	73-1/4" (7)	70.0	75.0	80.0	90.0	80.0	90.0	90.0	160.0
25-1/2"		70.0	75.0	80.0	90.0	80.0	90.0	90.0	160.0
31"		70.0	75.0	80.0	90.0	80.0	90.0	90.0	160.0
36"		70.0	75.0	80.0	90.0	80.0	90.0	90.0	160.0
39"		70.0	75.0	80.0	90.0	80.0	90.0	90.0	160.0
42"		70.0	75.0	80.0	90.0	80.0	90.0	90.0	160.0
43"		70.0	75.0	80.0	90.0	80.0	90.0	90.0	110.0
47"		-	-	-	-	80.0	90.0	90.0	110.0
52-1/8"		-	-	-	-	80.0	90.0	90.0	110.0
53-1/8"		-	-	-	-	80.0	90.0	90.0	110.0
54"	-	-	-	-	80.0	90.0	90.0	107.3	
18-1/8"	75" (8)	70.0	75.0	80.0	90.0	80.0	90.0	90.0	160.0
25-1/2"		70.0	75.0	80.0	90.0	80.0	90.0	90.0	160.0
31"		70.0	75.0	80.0	90.0	80.0	90.0	90.0	160.0
36"		70.0	75.0	80.0	90.0	80.0	90.0	90.0	160.0
39"		70.0	75.0	80.0	90.0	80.0	90.0	90.0	160.0
42"		70.0	75.0	80.0	90.0	80.0	90.0	90.0	160.0
43"		70.0	75.0	80.0	90.0	80.0	90.0	90.0	110.0
47"		-	-	-	-	80.0	90.0	90.0	110.0
52-1/8"		-	-	-	-	80.0	90.0	90.0	110.0
53-1/8"		-	-	-	-	80.0	90.0	90.0	108.8
54"	-	-	-	-	80.0	90.0	90.0	106.1	
18-1/8"	78" (8)	70.0	75.0	80.0	90.0	80.0	90.0	90.0	160.0
25-1/2"		70.0	75.0	80.0	90.0	80.0	90.0	90.0	160.0
31"		70.0	75.0	80.0	90.0	80.0	90.0	90.0	160.0
36"		70.0	75.0	80.0	90.0	80.0	90.0	90.0	160.0
39"		70.0	75.0	80.0	90.0	80.0	90.0	90.0	160.0
42"		-	-	-	-	80.0	90.0	90.0	110.0
43"		-	-	-	-	80.0	90.0	90.0	110.0
47"		-	-	-	-	80.0	90.0	90.0	110.0
52-1/8"		-	-	-	-	80.0	90.0	90.0	110.0
53-1/8"		-	-	-	-	80.0	90.0	90.0	107.0
54"	-	-	-	-	80.0	90.0	90.0	104.2	
18-1/8"	81" (8)	70.0	75.0	80.0	90.0	80.0	90.0	90.0	160.0
25-1/2"		70.0	75.0	80.0	90.0	80.0	90.0	90.0	160.0
31"		70.0	75.0	80.0	90.0	80.0	90.0	90.0	160.0
36"		70.0	75.0	80.0	90.0	80.0	90.0	90.0	160.0
39"		70.0	75.0	80.0	90.0	80.0	90.0	90.0	160.0
42"		-	-	-	-	80.0	90.0	90.0	110.0
43"		-	-	-	-	80.0	90.0	90.0	110.0
47"		-	-	-	-	80.0	90.0	90.0	110.0
52-1/8"		-	-	-	-	80.0	90.0	90.0	108.7
53-1/8"		-	-	-	-	80.0	90.0	90.0	108.7

NOTE:
GLASS CAPACITIES ON THIS SHEET ARE
BASED ON ASTM E1300-09 (3 SEC. GUSTS)
AND FLORIDA BUILDING COMMISSION
DECLARATORY STATEMENT DCA05-DEC-219

EQUAL LITES WINDOWS DESIGN LOAD CAPACITY - PSF						
INTERIOR FRAME DIMS.		5/16" ANCHORS 1/2" MAX. SHIM		5/16" ANCHORS 1/4" MAX. SHIM		
		GLASS TYPE 'A1'		GLASS TYPE 'C'		
WIDTH	HEIGHT	EXT.(+)	INT.(-)	EXT.(+)	INT.(-)	
18-1/8"	87" (9)	80.0	90.0	90.0	160.0	
25-1/2"		80.0	90.0	90.0	160.0	
31"		80.0	90.0	90.0	160.0	
36"		80.0	90.0	90.0	160.0	
39"		80.0	90.0	90.0	110.0	
42"		80.0	90.0	90.0	110.0	
43"		80.0	90.0	90.0	110.0	
47"		80.0	90.0	90.0	110.0	
18-1/8"		90" (9)	80.0	90.0	90.0	160.0
25-1/2"			80.0	90.0	90.0	160.0
31"	80.0		90.0	90.0	160.0	
36"	80.0		90.0	90.0	110.0	
39"	80.0		90.0	90.0	110.0	
43"	80.0	90.0	90.0	110.0		
18-1/8"	96" (9)	80.0	90.0	90.0	160.0	
25-1/2"		80.0	90.0	90.0	160.0	
31"		80.0	90.0	90.0	160.0	
36"		80.0	90.0	90.0	110.0	
39"		80.0	90.0	90.0	110.0	
43"	80.0	90.0	90.0	110.0		

* NUMBER IN PARENTHESIS INDICATE
MIN. NO. OF ANCHORS PER JAMB.

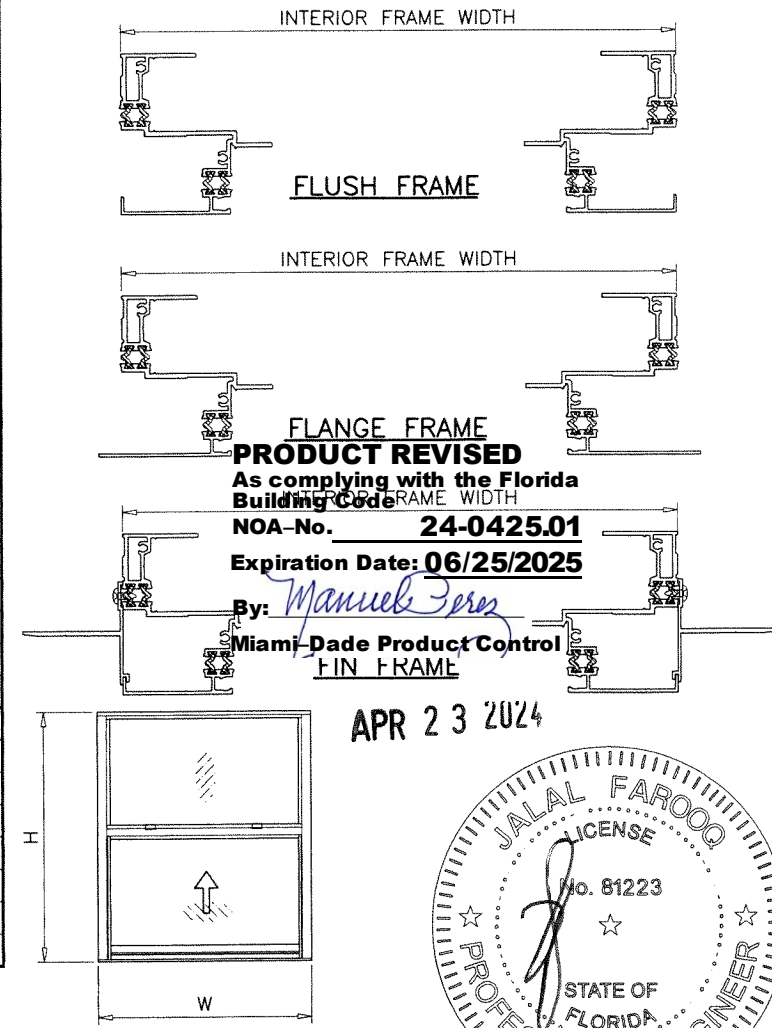

AL-FAROOQ CORPORATION
ENGINEERS & PRODUCT DEVELOPMENT
9360 SUNSET DRIVE, SUITE 220
MIAMI, FLORIDA 33173
TEL. (305) 264-8100 FAX. (305) 262-6978
COMP-ANL\W14-39-ESW

ES-H340 THERMAL ALUM SINGLE HUNG WDW. (L.M.I.)
E.S. WINDOWS, LLC
3550 N.W. 49 STREET
MIAMI, FL. 33142
TEL. (305) 638-5151 FAX. (305) 638-5158

revisions:	no	date	description
	A	05.21.15	REV. PER COMMENTS
	B	11.01.17	GENERAL REVISION
	C	03.06.24	GENERAL REVISION
date:	10-10-14		
scale:	1/2" = 1'-0"		
dr. by:	TARIO		
chk. by:			
drawing no.	W14-39		
sheet	3 of 11		

UNEQUAL LITES (ORIEL TYPE) WDWS. DESIGN LOAD CAPACITY - PSF									
INTERIOR FRAME DIMS.		MIN. VENT HEIGHT	1/4" ANCHORS 1/4" MAX. SHIM				5/16" ANCHORS 1/4" MAX. SHIM		
			GLASS TYPE 'B1'		GLASS TYPES 'A' & 'B'		GLASS TYPE 'C'		
WIDTH	HEIGHT		EXT.(+)	1NT.(-)	EXT.(+)	1NT.(-)	EXT.(+)	1NT.(-)	
18-1/8"	49-5/8"	24-13/16"	70.0	75.0	80.0	90.0	90.0	160.0	
25-1/2"			70.0	75.0	80.0	90.0	90.0	160.0	
31"			70.0	75.0	80.0	90.0	90.0	160.0	
36"			70.0	75.0	80.0	90.0	90.0	160.0	
39"			70.0	75.0	80.0	90.0	90.0	160.0	
43"			(5)	70.0	75.0	80.0	90.0	90.0	110.0
47"			70.0	75.0	80.0	90.0	90.0	110.0	
52-1/8"			70.0	75.0	80.0	90.0	90.0	110.0	
53-1/8"			70.0	75.0	80.0	90.0	90.0	110.0	
54"			70.0	75.0	80.0	90.0	90.0	110.0	
18-1/8"	55"	27-1/2"	70.0	75.0	80.0	90.0	90.0	160.0	
25-1/2"			70.0	75.0	80.0	90.0	90.0	160.0	
31"			70.0	75.0	80.0	90.0	90.0	160.0	
36"			70.0	75.0	80.0	90.0	90.0	160.0	
39"			70.0	75.0	80.0	90.0	90.0	160.0	
43"			(6)	70.0	75.0	80.0	90.0	90.0	110.0
47"			70.0	75.0	80.0	90.0	90.0	110.0	
52-1/8"			70.0	75.0	80.0	90.0	90.0	110.0	
53-1/8"			70.0	75.0	80.0	90.0	90.0	110.0	
54"			70.0	75.0	80.0	90.0	90.0	110.0	
18-1/8"	62"	31"	70.0	75.0	80.0	90.0	90.0	160.0	
25-1/2"			70.0	75.0	80.0	90.0	90.0	160.0	
31"			70.0	75.0	80.0	90.0	90.0	160.0	
36"			70.0	75.0	80.0	90.0	90.0	110.0	
39"			70.0	75.0	80.0	90.0	90.0	110.0	
43"			(6)	70.0	75.0	80.0	90.0	90.0	110.0
47"			70.0	75.0	80.0	90.0	90.0	110.0	
52-1/8"			70.0	75.0	80.0	90.0	90.0	110.0	
53-1/8"			70.0	75.0	80.0	90.0	90.0	110.0	
54"			70.0	75.0	80.0	88.9	90.0	110.0	
18-1/8"	69"	34-1/2"	70.0	75.0	80.0	90.0	90.0	160.0	
25-1/2"			70.0	75.0	80.0	90.0	90.0	160.0	
31"			70.0	75.0	80.0	90.0	90.0	110.0	
36"			70.0	75.0	80.0	90.0	90.0	110.0	
39"			70.0	75.0	80.0	90.0	90.0	110.0	
43"			(7)	70.0	75.0	80.0	90.0	90.0	110.0
47"			70.0	75.0	80.0	90.0	90.0	110.0	
52-1/8"			-	-	-	-	90.0	110.0	
53-1/8"			-	-	-	-	90.0	110.0	
54"			-	-	-	-	90.0	110.0	
18-1/8"	73-1/4"	36-5/8"	70.0	75.0	80.0	90.0	90.0	160.0	
25-1/2"			70.0	75.0	80.0	90.0	90.0	160.0	
31"			70.0	75.0	80.0	90.0	90.0	110.0	
36"			70.0	75.0	80.0	90.0	90.0	110.0	
39"			70.0	75.0	80.0	90.0	90.0	110.0	
43"			(7)	70.0	75.0	80.0	90.0	90.0	110.0
47"			-	-	-	-	90.0	110.0	
52-1/8"			-	-	-	-	90.0	110.0	
53-1/8"			-	-	-	-	90.0	110.0	
54"			-	-	-	-	90.0	107.3	

UNEQUAL LITES (ORIEL TYPE) WDWS. DESIGN LOAD CAPACITY - PSF									
INTERIOR FRAME DIMS.		MIN. VENT HEIGHT	1/4" ANCHORS 1/4" MAX. SHIM				5/16" ANCHORS 1/4" MAX. SHIM		
			GLASS TYPE 'B1'		GLASS TYPES 'A' & 'B'		GLASS TYPE 'C'		
WIDTH	HEIGHT		EXT.(+)	1NT.(-)	EXT.(+)	1NT.(-)	EXT.(+)	1NT.(-)	
18-1/8"	75"	37-1/2"	70.0	75.0	80.0	90.0	90.0	160.0	
25-1/2"			70.0	75.0	80.0	90.0	90.0	160.0	
31"			70.0	75.0	80.0	90.0	90.0	110.0	
36"			70.0	75.0	80.0	90.0	90.0	110.0	
39"			70.0	75.0	80.0	90.0	90.0	110.0	
43"			(8)	70.0	75.0	80.0	90.0	90.0	110.0
47"			-	-	-	-	90.0	110.0	
52-1/8"			-	-	-	-	90.0	110.0	
53-1/8"			-	-	-	-	90.0	108.8	
54"			-	-	-	-	90.0	106.1	
18-1/8"	78"	39"	70.0	75.0	80.0	90.0	90.0	160.0	
25-1/2"			70.0	75.0	80.0	90.0	90.0	160.0	
31"			70.0	75.0	80.0	90.0	90.0	110.0	
36"			70.0	75.0	80.0	90.0	90.0	110.0	
39"			70.0	75.0	80.0	90.0	90.0	110.0	
43"			(8)	-	-	-	90.0	110.0	
47"			-	-	-	-	90.0	110.0	
52-1/8"			-	-	-	-	90.0	110.0	
53-1/8"			-	-	-	-	90.0	107.0	
54"			-	-	-	-	90.0	104.2	
18-1/8"	81"	39-1/8"	70.0	75.0	80.0	90.0	90.0	160.0	
25-1/2"			70.0	75.0	80.0	90.0	90.0	110.0	
31"			70.0	75.0	80.0	90.0	90.0	110.0	
36"			70.0	75.0	80.0	90.0	90.0	110.0	
39"			70.0	75.0	80.0	90.0	90.0	110.0	
43"			(8)	-	-	-	90.0	110.0	
47"			-	-	-	-	90.0	110.0	
52-1/8"			-	-	-	-	90.0	108.7	
53-1/8"			-	-	-	-	90.0	105.4	
54"			-	-	-	-	90.0	102.7	
18-1/8"	96"	39-1/8"	-	-	-	-	90.0	160.0	
25-1/2"			-	-	-	-	90.0	110.0	
31"			-	-	-	-	90.0	110.0	
36"			-	-	-	-	90.0	110.0	
39"			-	-	-	-	90.0	110.0	
43"			(9)	-	-	-	90.0	110.0	
47"			-	-	-	-	90.0	110.0	
52-1/8"			-	-	-	-	90.0	106.6	
53-1/8"			-	-	-	-	90.0	103.0	
54"			-	-	-	-	90.0	100.0	

* NUMBER IN PARENTHESIS INDICATE
MIN. NO. OF ANCHORS PER JAMB.

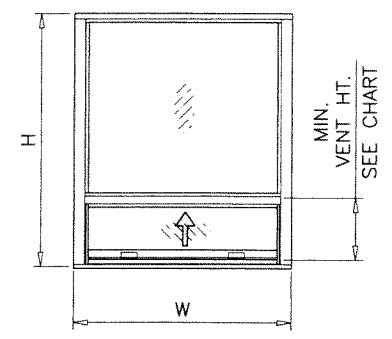

NOTE:
GLASS CAPACITIES ON THIS SHEET ARE
BASED ON ASTM E1300-09 (3 SEC. GUSTS)
AND FLORIDA BUILDING COMMISSION
DECLARATORY STATEMENT DCA05-DEC-219

PRODUCT REVISED
As complying with the Florida
Building Code
NOA-No. **24-0425.01**
Expiration Date: **06/25/2025**
By: *Manuel Perez*
Miami-Dade Product Control

APR 23 2024

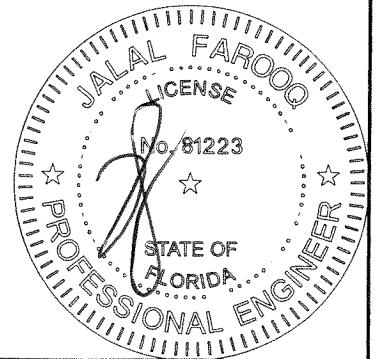

af c
AL-FAROOQ CORPORATION
ENGINEERS & PRODUCT DEVELOPMENT
9360 SUNSET DRIVE, SUITE 220 (C.A.N. 353B)
MIAMI, FLORIDA 33173 TEL. (305) 262-6978 FAX. (305) 264-8100
COMP - ANL W14-39-ESW

ES-H340 THERMAL ALUM SINGLE HUNG WDWS. (L.M.I.)
E.S. WINDOWS, LLC
3550 N.W. 49 STREET
MIAMI, FL. 33142
TEL. (305) 638-5151 FAX. (305) 638-5158

no	date	by description
C	03.06.24	GENERAL REVISION

date: 10-10-14
scale: 1/2"=1'-0"
dr. by: TARIQ
chk. by:

drawing no. **W14-39**
sheet **3.1** of **11**

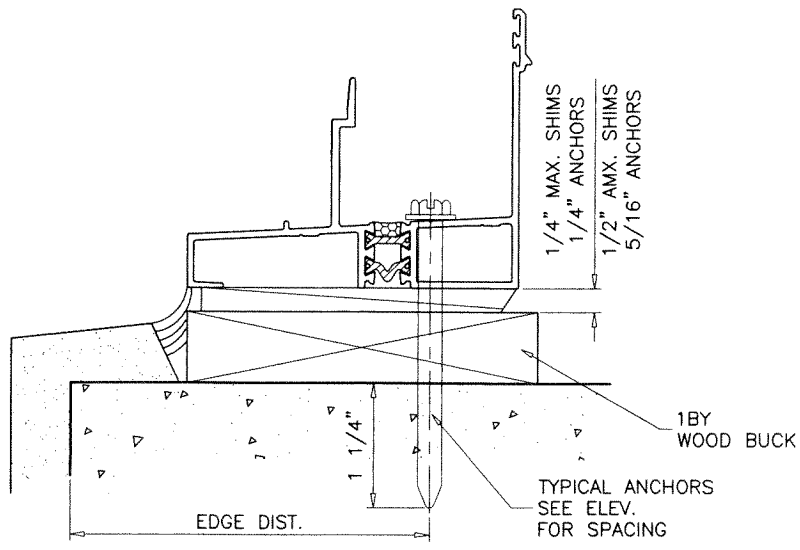
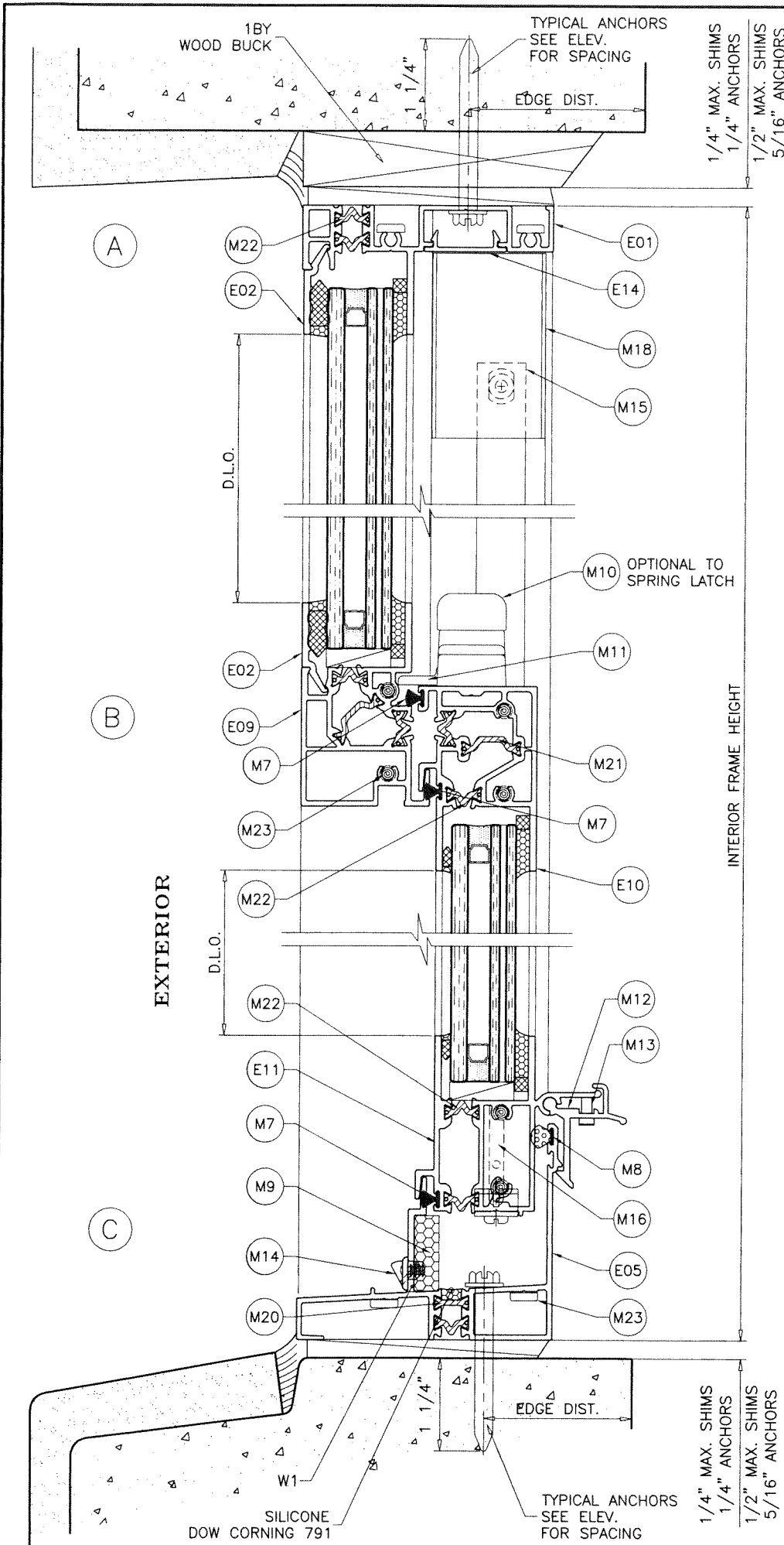

WEEPHOLES:

W1 = 1-7/8" X 1/4" WEEPHOLES AT 6-1/2" FROM EACH END

PRODUCT REVISED
 As complying with the Florida Building Code
 NOA-No. **24-0425.01**
 Expiration Date: **06/25/2025**
 By: *Manuel Ferrer*
 Miami-Dade Product Control

APR 23 2024

FLUSH FRAMES

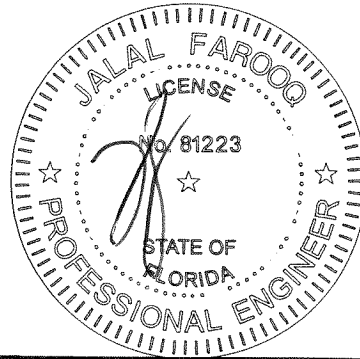

af c

AL-FAROOQ CORPORATION
 ENGINEERS & PRODUCT DEVELOPMENT
 9360 SUNSET DRIVE, SUITE 220
 MIAMI, FLORIDA 33173 (C.A.N. 3538)
 TEL. (305) 264-8100 FAX. (305) 262-6978
 COMP-ANL\W14-39-ESW

ES-H340 THERMAL ALUM SINGLE HUNG WDW. (L.M.I.)

E.S. WINDOWS, LLC
 3550 N.W. 49 STREET
 MIAMI, FL. 33142
 TEL. (305) 638-5151 FAX. (305) 638-5158

no	date	by	description
A	05.21.15	REV. PER RER	COMMENTS
B	11.01.17	GENERAL REVISION	
C	03.06.24	GENERAL REVISION	

revisions:

date: 10-10-14
 scale: 1/2" = 1"
 dr. by: TARIQ
 chk. by:

drawing no. **W14-39**
 sheet 4 of 11

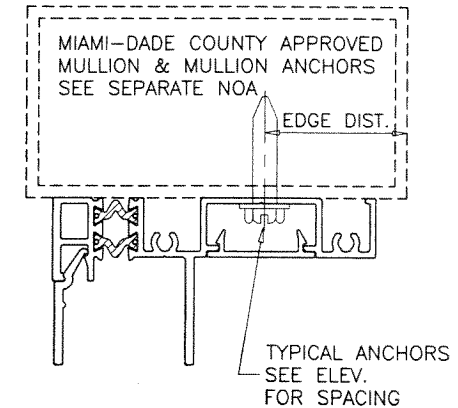
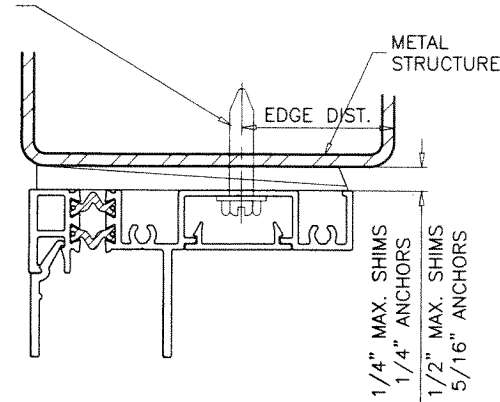
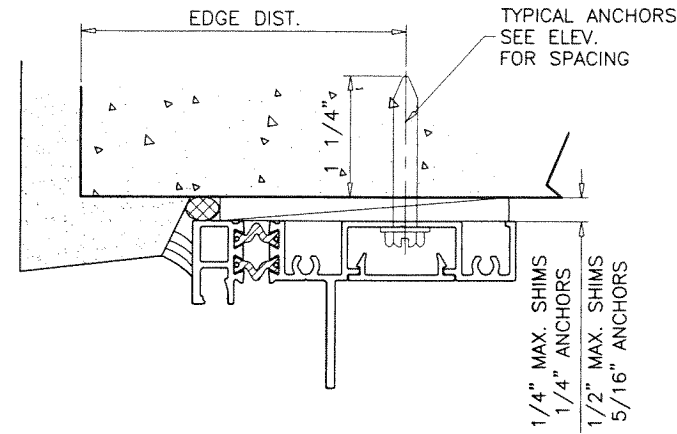
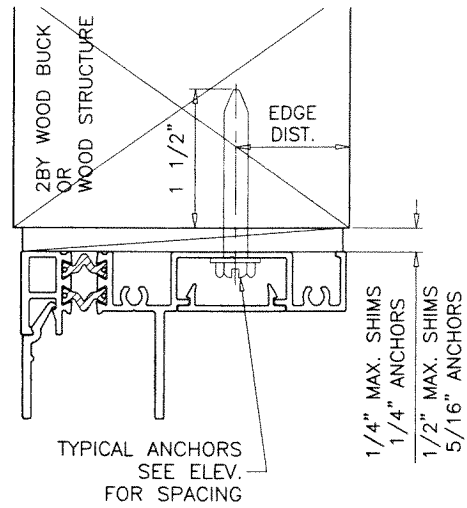

TYPICAL ANCHORS: SEE ELEV. FOR SPACING

1/4" MAX. SHIMS

1/4" DIA. CRETE-FLEX SS4 BY 'DEWALT' (Fu=190 KSI, Fy=127 KSI)

1/4" DIA. AGGRE-GATOR 300 BY 'DEWALT' (Fu=96 KSI, Fy=57 KSI)

1/4" DIA. ULTRACON+ BY 'DEWALT' (Fu=164 KSI, Fy=148 KSI)

INTO 2BY WOOD BUCKS OR WOOD STRUCTURES
1-1/2" MIN. PENETRATION INTO WOOD (HEAD/SILL/JAMBS)

THRU 1BY BUCKS INTO CONC. OR BLOCKS
1-1/4" MIN. EMBED INTO CONCRETE (HEAD/SILL/JAMBS)
1-1/4" MIN. EMBED INTO BLOCKS (JAMBS)

DIRECTLY INTO CONC. OR BLOCKS
1-1/4" MIN. EMBED INTO CONCRETE (HEAD/SILL/JAMBS)
1-1/4" MIN. EMBED INTO BLOCKS (JAMBS)

1/4" DIA. ULTRACON SS4 410 BY 'DEWALT' (Fu=190 KSI, Fy=164 KSI)

INTO 2BY WOOD BUCKS OR WOOD STRUCTURES
1-1/2" MIN. PENETRATION INTO WOOD (HEAD/SILL/JAMBS)

THRU 1BY BUCKS INTO CONC. OR BLOCKS
1-1/4" MIN. EMBED INTO CONCRETE (HEAD/SILL/JAMBS)
1-1/4" MIN. EMBED INTO GROUT-FILLED BLOCKS (JAMBS)

DIRECTLY INTO CONC. OR BLOCKS
1-1/4" MIN. EMBED INTO CONCRETE (HEAD/SILL/JAMBS)
1-1/4" MIN. EMBED INTO GROUT-FILLED BLOCKS (JAMBS)

1/4" DIA. BI-FLEX 300 SELF DRILLING SCREWS BY 'DEWALT'

1/4" DIA. DRIL-FLEX SELF DRILLING SCREWS BY 'DEWALT' (Fu=100 KSI, Fy= 65 KSI)

INTO MIAMI-DADE COUNTY APPROVED MULLIONS
OR
INTO METAL STRUCTURES (HEAD/SILL/JAMBS)
(3) THREADS MIN. PENETRATION BEYOND SUBSTRATE
ALUMINUM: 1/8" THK. MIN. (6063-T5 MIN.)
STEEL: 1/8" THK. MIN. (Fy = 36 KSI MIN.)
(STEEL IN CONTACT WITH ALUMINUM TO BE PLATED OR PAINTED)

ANCHOR EDGE DISTANCES

INTO CONCRETE AND BLOCKS = 2-1/2" MIN.
INTO WOOD STRUCTURE = 1" MIN.
INTO METAL STRUCTURE = 3/4" MIN.

WOOD AT HEAD, SILL OR JAMBS SG = 0.55 MIN.
CONCRETE AT HEAD, SILL OR JAMBS f'c = 3000 PSI MIN.
C-90 HOLLOW/FILLED BLOCK AT JAMBS f'm = 2000 PSI MIN.

TYPICAL ANCHORS: SEE ELEV. FOR SPACING

1/2" MAX. SHIMS

5/16" DIA. ULTRACON BY 'DEWALT' (Fu=177 KSI, Fy=155 KSI)

INTO 2BY WOOD BUCKS OR WOOD STRUCTURES
1-1/2" MIN. PENETRATION INTO WOOD (HEAD/SILL/JAMBS)

THRU 1BY BUCKS INTO CONC. OR BLOCKS
1-1/4" MIN. EMBED INTO CONCRETE (HEAD/SILL/JAMBS)
1-1/4" MIN. EMBED INTO BLOCKS (JAMBS)

DIRECTLY INTO CONCRETE OR BLOCKS
1-1/4" MIN. EMBED INTO CONCRETE (HEAD/SILL/JAMBS)
1-1/4" MIN. EMBED INTO BLOCKS (JAMBS)

5/16" DIA. DRIL-FLEX SELF DRILLING SCREWS BY 'DEWALT' (Fu=100 KSI, Fy= 65 KSI)

INTO MIAMI-DADE COUNTY APPROVED MULLIONS
OR
INTO METAL STRUCTURES (HEAD/SILL/JAMBS)
(3) THREADS MIN. PENETRATION BEYOND SUBSTRATE
ALUMINUM: 1/8" THK. MIN. (6063-T5 MIN.)
STEEL: 1/8" THK. MIN. (Fy = 36 KSI MIN.)
(STEEL IN CONTACT WITH ALUMINUM TO BE PLATED OR PAINTED)

TYPICAL EDGE DISTANCE

INTO CONCRETE AND MASONRY = 2-1/2" MIN.
INTO WOOD STRUCTURE = 1-1/4" MIN.
INTO METAL STRUCTURE = 3/4" MIN.

WOOD AT HEAD, SILL OR JAMBS SG = 0.55 MIN.
CONCRETE AT HEAD, SILL OR JAMBS f'c = 3000 PSI MIN.
C-90 HOLLOW/FILLED BLOCK AT JAMBS f'm = 2000 PSI MIN.

WOOD BUCKS AND METAL STRUCTURE NOT BY 'E.S. WINDOWS'
MUST SUSTAIN LOADS IMPOSED BY GLAZING SYSTEM
AND TRANSFER THEM TO THE BUILDING STRUCTURE.

PRODUCT REVISED
As complying with the Florida Building Code
NOA-No. **24-0425.01**
Expiration Date: **06/25/2025**
By: *Manuel Ferrer*
Miami-Dade Product Control

APR 23 2024

FLUSH FRAMES

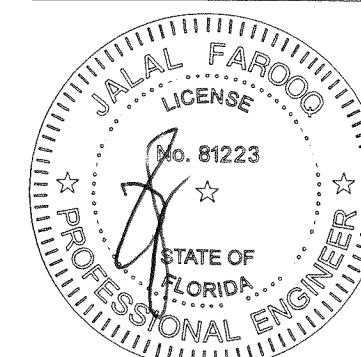

af c
AL-FAROOQ CORPORATION
ENGINEERS & PRODUCT DEVELOPMENT
9360 SUNSET DRIVE, SUITE 220
MIAMI, FLORIDA 33173
TEL. (305) 264-8100 FAX. (305) 262-6978
(C.A.N. 3538)
COMP-ANL\W14-39-ESW

ES-H340 THERMAL ALUM SINGLE HUNG WDW. (L.M.I.)
E.S. WINDOWS, LLC
3550 N.W. 49 STREET
MIAMI, FL. 33142
TEL. (305) 638-5151 FAX. (305) 638-5158

no	date	by	description
B	11.01.17		GENERAL REVISION
C	03.06.24		GENERAL REVISION

date:	10-10-14
scale:	1/2" = 1"
dr. by:	TARIQ
chk. by:	

drawing no.
W14-39
sheet 5 of 11

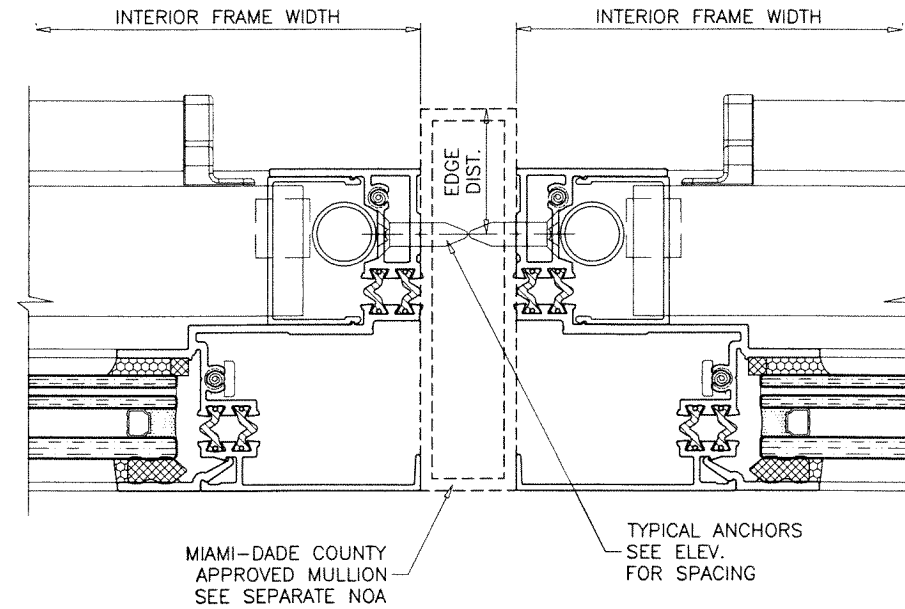
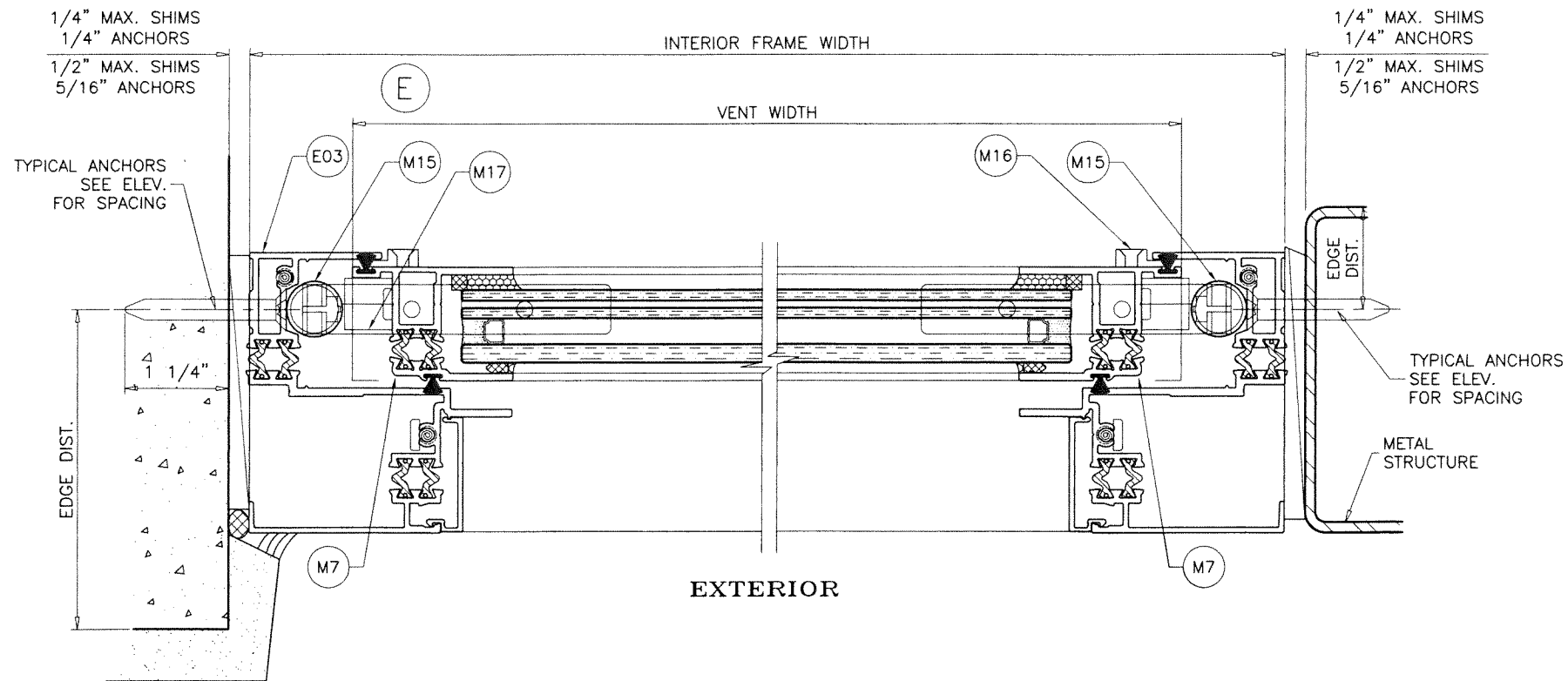
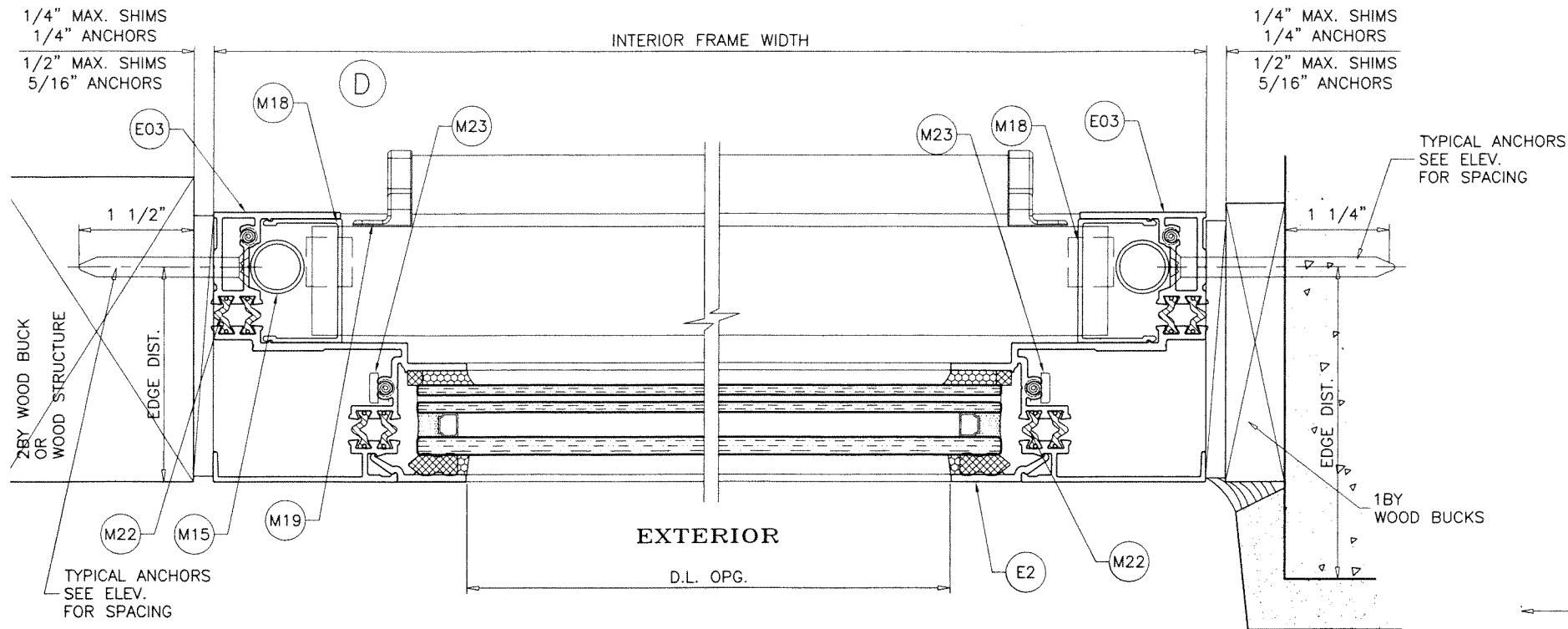

PRODUCT REVISED
 As complying with the Florida Building Code
 NOA-No. **24-0425.01**
 Expiration Date: **06/25/2025**
 By: *Manuel Fern*
 Miami-Dade Product Control

APR 23 2024

FLUSH FRAMES

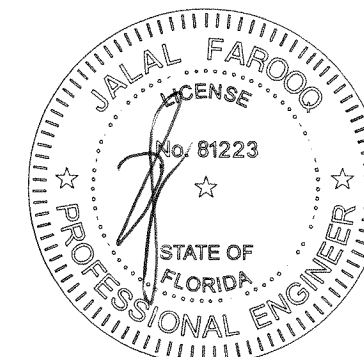

af c
AL-FAROOQ CORPORATION
 ENGINEERS & PRODUCT DEVELOPMENT
 9360 SUNSET DRIVE, SUITE 220
 MIAMI, FLORIDA 33173 (C.A.N. 3538)
 TEL. (305) 264-8100 FAX. (305) 262-6978
 COMP-ANL W14-39-ESW

ES-H340 THERMAL ALUM SINGLE HUNG WDW. (L.M.I.)
E.S. WINDOWS, LLC
 3550 N.W. 49 STREET
 MIAMI, FL. 33142
 TEL. (305) 638-5151 FAX. (305) 638-5158

no	date	by	description
A	05.21.15	REV. PER	REVISION
B	11.01.17	GENERAL	REVISION
C	03.06.24	GENERAL	REVISION

date: 10-10-14
 scale: 1/2" = 1"
 dr. by: TARIQ
 chk. by:

drawing no.
W14-39
 sheet 6 of 11

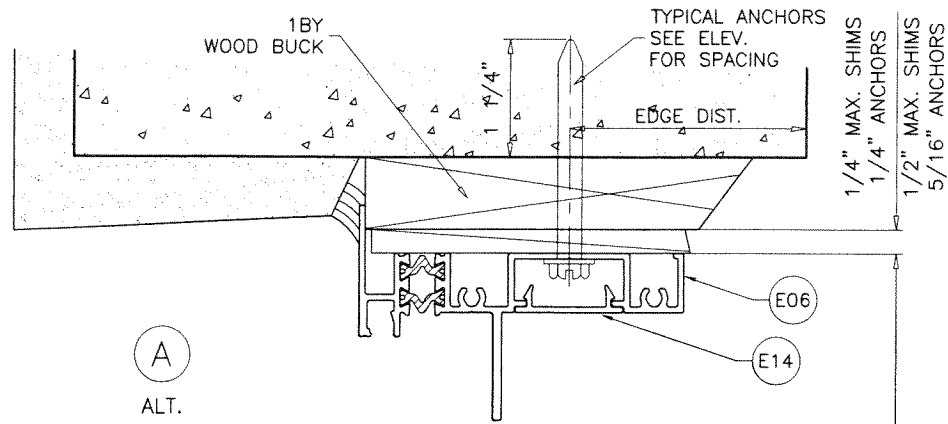

A
ALT.

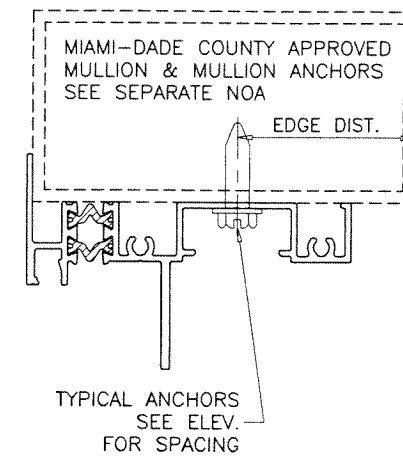
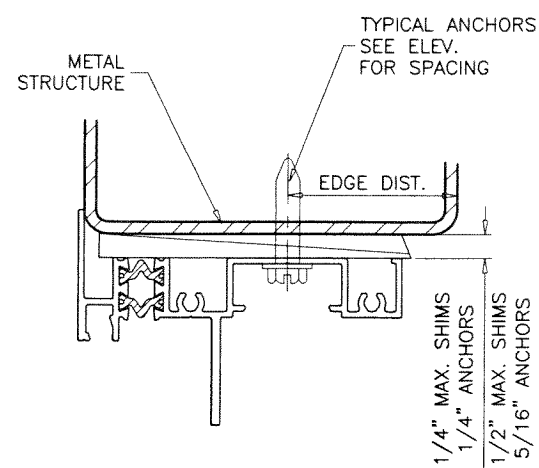
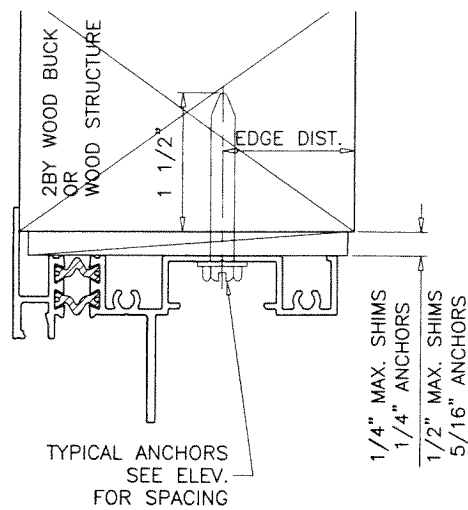

INTERIOR FRAME HEIGHT

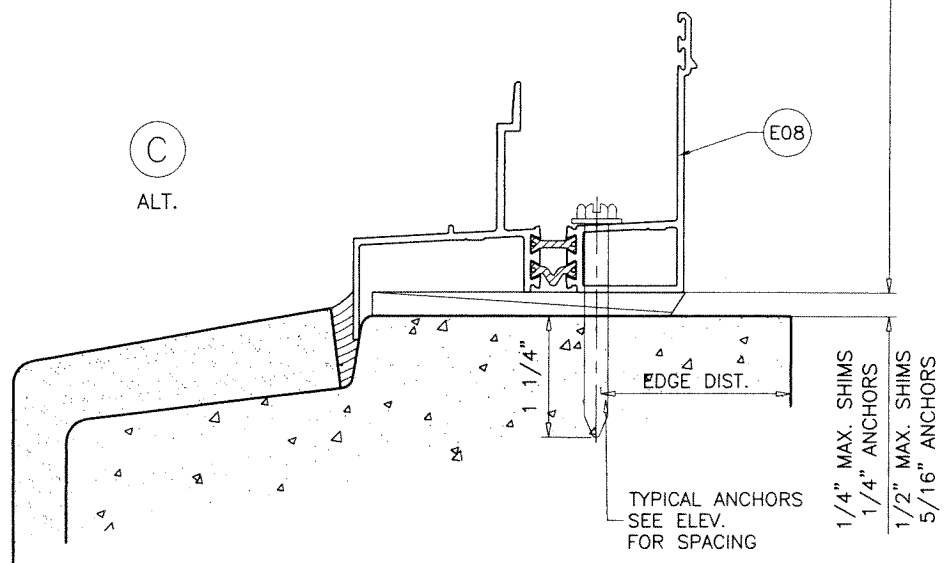

C
ALT.

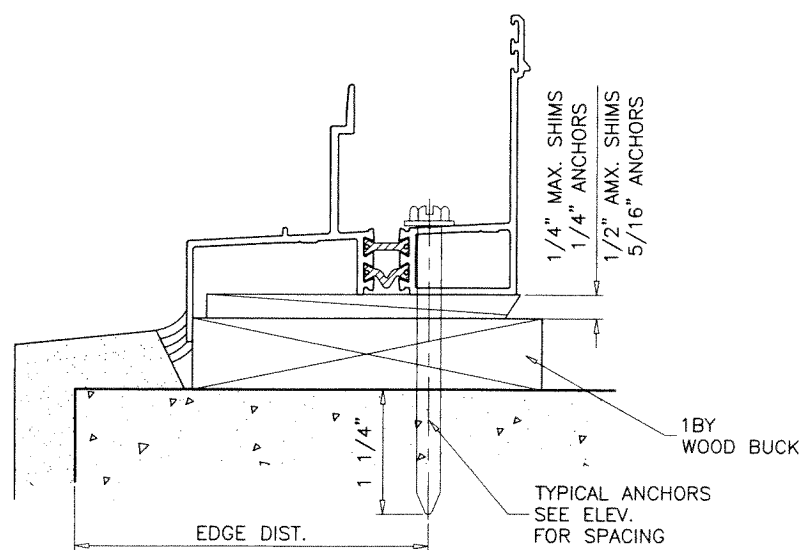

INSTALLATION DETAILS FLANGE FRAMES
SEE SHEETS 4 THRU 6 FOR WINDOW DETAILS

PRODUCT REVISED
As complying with the Florida Building Code
NOA-No. **24-0425.01**
Expiration Date: **06/25/2025**
By: *Manuel Ferrer*
Miami-Dade Product Control

APR 23 2024

FLANGE FRAMES

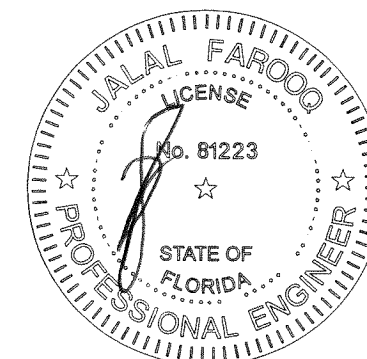

af c
AL-FAROOQ CORPORATION
ENGINEERS & PRODUCT DEVELOPMENT
9360 SUNSET DRIVE, SUITE 220
MIAMI, FLORIDA 33173
TEL. (305) 264-8100 FAX. (305) 262-6978
C.A.N. 3538

ES-H340 THERMAL ALUM SINGLE HUNG WD.W. (L.M.I.)
E.S. WINDOWS, LLC
3550 N.W. 49 STREET
MIAMI, FL. 33142
TEL. (305) 638-5151 FAX. (305) 638-5158

no	date	by	description
A	05.21.15	REV. PER	COMMENTS
B	11.01.17	GENERAL	REVISION
C	03.06.24	GENERAL	REVISION

date:	10-10-14
scale:	1/2" = 1"
dr. by:	TARIO
chk. by:	

drawing no.	W14-39
sheet	7 of 11

COMP-ANL\W14-39-ESW

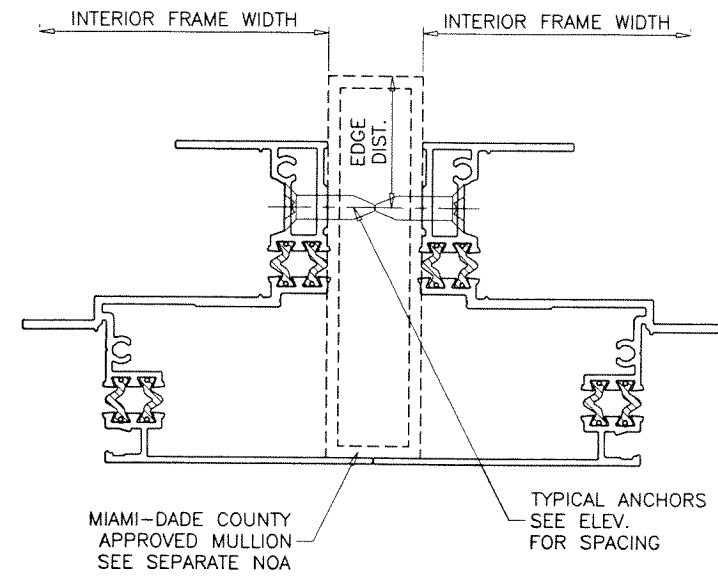
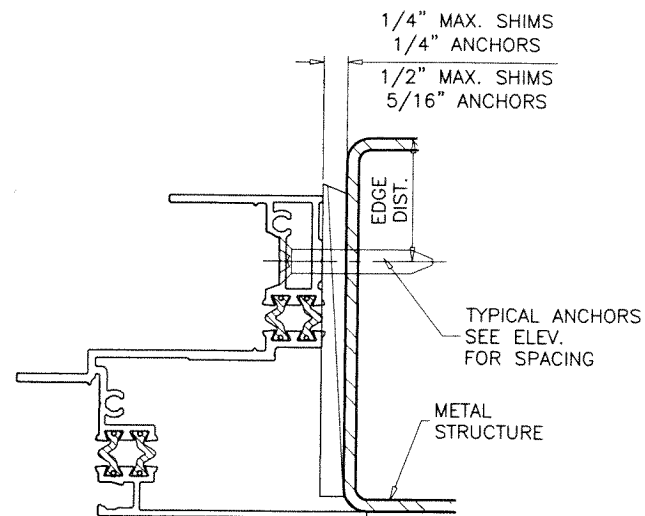
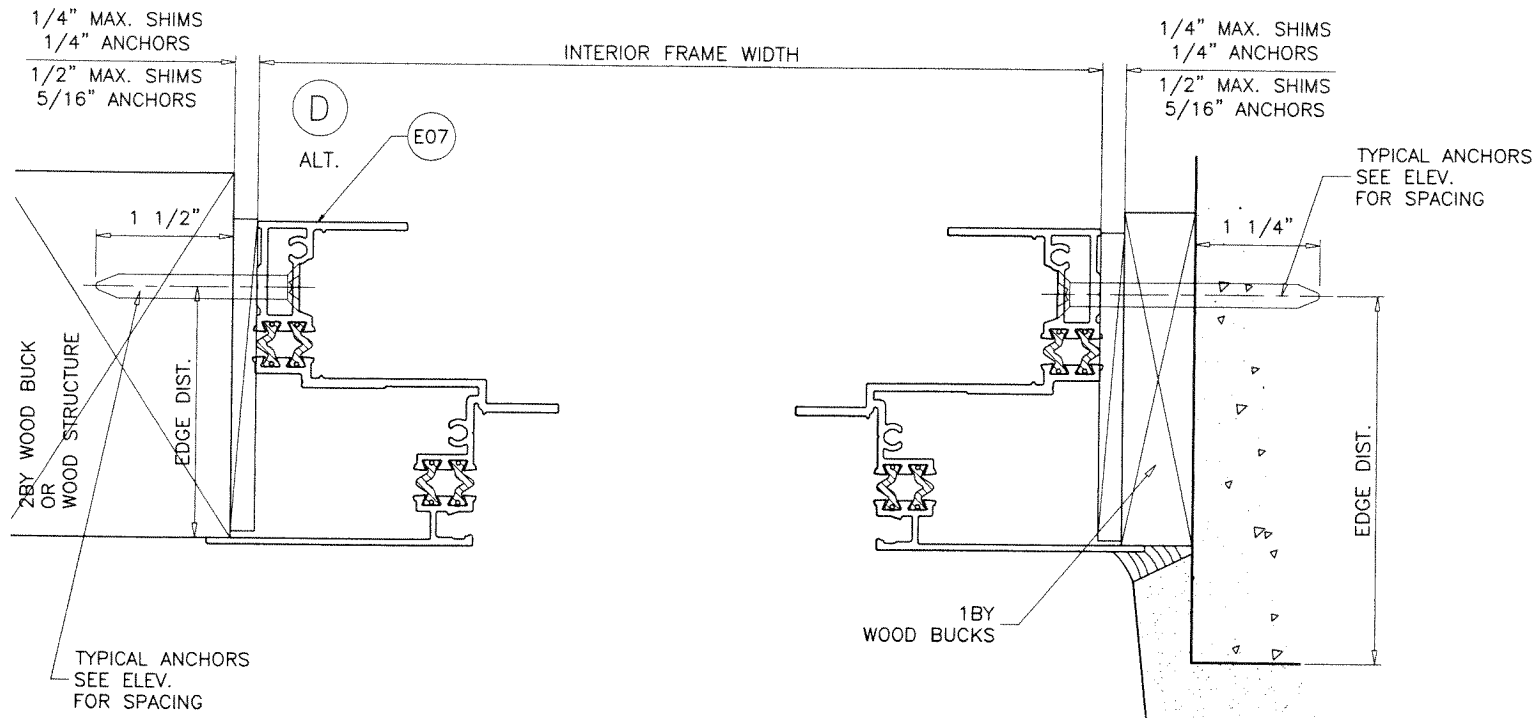

INSTALLATION DETAILS FLANGE FRAMES
SEE SHEETS 4 THRU 6 FOR WINDOW DETAILS

PRODUCT REVISED
As complying with the Florida Building Code
NOA-No. **24-0425.01**
Expiration Date: **06/25/2025**
By: *Manuel Perez*
Miami-Dade Product Control

APR 23 2024

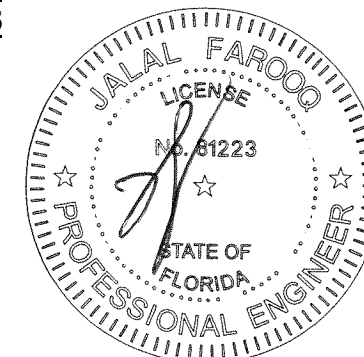

FLANGE FRAMES

af c
AL-FAROOQ CORPORATION
ENGINEERS & PRODUCT DEVELOPMENT
9360 SUNSET DRIVE, SUITE 220
MIAMI, FLORIDA 33173 (C.A.N. 3538)
TEL. (305) 264-8100 FAX. (305) 262-6978
COMP-ANL\W14-39-ESW

ES-H340 THERMAL ALUM SINGLE HUNG WDW. (L.M.I.)
E.S. WINDOWS, LLC
3550 N.W. 49 STREET
MIAMI, FL. 33142
TEL. (305) 638-5151 FAX. (305) 638-5158

no	date	description	by
A	05.21.15	REV. PER RER COMMENTS	
B	11.01.17	GENERAL REVISION	
C	03.06.24	GENERAL REVISION	

date: 10-10-14
scale: 1/2" = 1"
dr. by: TARIQ
chk. by:

drawing no.
W14-39
sheet 8 of 11

ILLUSTRATIVE DTLS. ONLY
EXT. OR INT. FINISHES
NOT BY 'E.S. WDW.'

TYPICAL ANCHORS
SEE ELEV.
FOR SPACING

A
ALT.

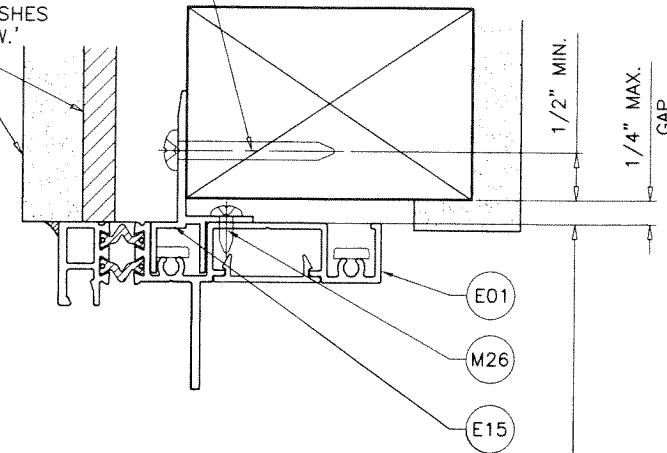

TYPICAL ANCHORS: SEE ELEV. FOR SPACING

#14 WOOD SCREWS (GRADE 2 CRS)
INTO 2BY WOOD BUCKS OR WOOD STRUCTURES
1-1/2" MIN. PENETRATION INTO WOOD

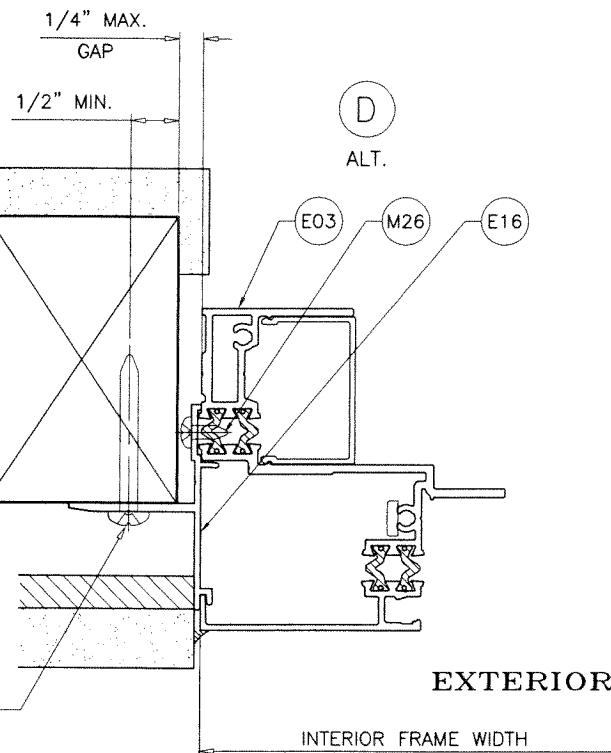

TYPICAL ANCHORS
SEE ELEV.
FOR SPACING

EXTERIOR

INTERIOR FRAME WIDTH

EXTERIOR

INTERIOR FRAME HEIGHT

C
ALT.

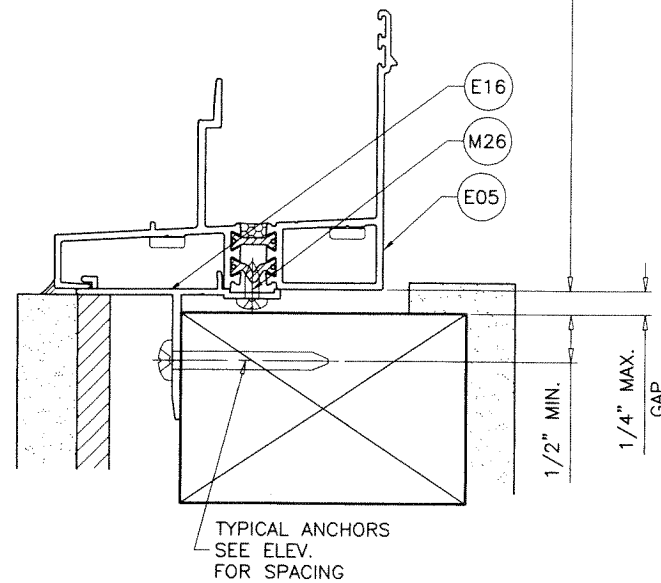

TYPICAL ANCHORS
SEE ELEV.
FOR SPACING

INSTALLATION DETAILS FLUSH FRAMES WITH NAIL FINES
SEE SHEETS 4 THRU 6 FOR WINDOW DETAILS

PRODUCT REVISED
As complying with the Florida
Building Code
NOA-No. **24-0425.01**
Expiration Date: **06/25/2025**
By: *Manuel Torres*
Miami-Dade Product Control

APR 23 2024

FIN FRAMES

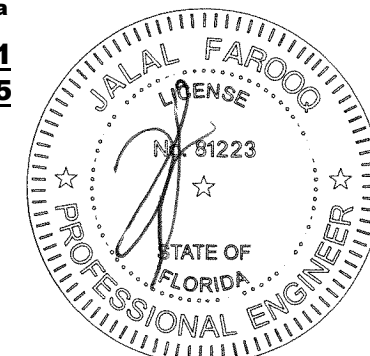

ES-H340 THERMAL ALUM SINGLE HUNG WDW. (L.M.I.)

E.S. WINDOWS, LLC
3550 N.W. 49 STREET
MIAMI, FL. 33142
TEL. (305) 638-5151 FAX. (305) 638-5158

no	date	description
C	03.06.24	GENERAL REVISION

date:	10-10-14
scale:	1/2" = 1"
dr. by:	TARIQ
chk. by:	

drawing no.
W14-39
sheet **8.1** of **11**

afc

AL-FAROOQ CORPORATION
ENGINEERS & PRODUCT DEVELOPMENT
9360 SUNSET DRIVE, SUITE 220
MIAMI, FLORIDA 33173
TEL. (305) 264-8100 FAX. (305) 262-6978
(C.A.N. 3538)

COMP-ANL\W14-39-ESW

ITEM #	PART #	REQD.	DESCRIPTION	MATERIAL	MANF./SUPPLIER/REMARKS
E01	ES-H340-501	1	FLUSH FRAME HEAD	6063-T6	-
E02	ES-H340-003	4/ LITE	GLASS STOP	6063-T6	-
E03	ES-H340-505	2	FLUSH FRAME JAMB	6063-T6	-
E04	ES-H340-007	AS REQD.	SCREEN ADAPTER/COVER	6063-T5	-
E05	ES-H340-503	1	FLUSH FRAME SILL	6063-T6	-
E06	ES-H340-502	1	FLANGE FRAME HEAD	6063-T6	-
E07	ES-H340-506	2	FLANGE FRAME JAMB	6063-T6	-
E08	ES-H340-504	1	FLANGE FRAME SILL	6063-T6	-
E09	ES-H340-507	1	FIXED INTERLOCK	6063-T6	-
E10	ES-H340-508	1	VENT INTERLOCK	6063-T6	-
E11	ES-H340-509	1	BOTTOM RAIL	6063-T6	-
E12	ES-H340-510	2	JAMB STILE	6063-T6	-
E13	ES-H340-021	-	JAMB TRIM	6063-T5	-
E14	ES-9502	AS REQD.	HEAD FRAME COVER	6063-T5	-
E15	ES-H340-029	AS REQD.	NAIL FIN (HEAD)	6063-T6	-
E16	ES-SW340-016	AS REQD.	NAIL FIN (SILL/JAMB)	6063-T6	-
M2	ES-H340-G02	AS REQD.	EXTERIOR GLAZING WEDGE (FIX. LITE)	SILICONE	DUROMETER 60±5 SHORE A
M2A	ES-H340-G02	AS REQD.	EXTERIOR GLAZING WEDGE (FIX. LITE)	SILICONE	DUROMETER 60±5 SHORE A
M3	ES-H340-G05	AS REQD.	EXTERIOR GLAZING WEDGE (VENT)	SILICONE	DUROMETER 60±5 SHORE A
M4	ES-21-B04A	AS REQD.	SETTING BLOCK	SILICONE	DUROMETER 80±5 SHORE A
M6	-	AS REQD.	INTERIOR GLAZING TAPE	POLYURETHANE	THERMALBOND
M6A	T-BOND V2206	AS REQD.	3/16" X 3/8" INTERIOR GLAZING TAPE	POLYURETHANE	THERMALBOND
M7	W23241NK	AS REQD.	PILE W'STRIPPING	-	-
M8	Q300T190	AS REQD.	Q-LONG W'STRIPPING	-	-
M9	WPSA	1/ WEEP	FOAM PAD, 2" X 1" X 5/8"	FOAM	OPEN CELL
M10	3032	2/ VENT	SWEEP LOCK	DIE CAST ALUM.	-
M11	ES1050-PL1	-	SWEEP LOCK FLAT BOLT	ST. STEEL	-
M12	SK08-4000.000	-	VENT LATCH INTERLOCK	DIE CAST ALUM	-
M13	ES-1012	-	LATCH SPRING LS 4050	ST. STEEL	-
M14	WA2L	-	WEEP HOLE COVER	RIGID PVC	-
M15	30-31	2/ VENT	ULTRA LIFT BALANCE	STEEL ROD	-
M16	-	2/ VENT	BALANCE GUIDE	NYLON	FASTENED W/ (1) #8 X 1/2" FH SMS
M17	21803	-	NON TILT	ST. STEEL	-
M18	ES-H340-P01	-	SASH STOP	RIGID PVC	-
M19	ES-1000-P1	-	NOTCH CAP	NYLON	-
M20	2310	-	INSULBAR 10MM FLAT	POLYAMIDE	ENSINGER
M21	1673	-	INSULBAR 20MM OFFSET	POLYAMIDE	ENSINGER
M22	-	-	INSULBAR 12MM OFFSET	POLYAMIDE	ENSINGER
M23	#10 X 1-1/4"	AS REQD.	ASSEMBLY FASTENERS	ST. STEEL	PH SMS
M24	#8 X 1/2"	-	NON TILT SCREWS	ST. STEEL	PH SMS
M25	#6 X 1/2"	-	BALANCE GUIDE SCREWS	ST. STEEL	FH SMS
M26	#8 X 3/8"	-	NAIL FIN FASTENERS AT 3" FROM ENDS & 12" O.C.	ST. STEEL	PH SMS

SEALANTS:

FRAME AND VENT CORNERS AND INSTALLATION SCREWS AT SILL SEALED WITH WHITE/ALUMINUM COLORED GENERAL PURPOSE SILICONE SEALANT BY MACKLANBURG-DUNCAN.

PRODUCT REVISED
 As complying with the Florida Building Code
 NOA-No. **24-0425.01**
 Expiration Date: **06/25/2025**
 By: *Manuel Fern*
 Miami-Dade Product Control

APR 23 2024

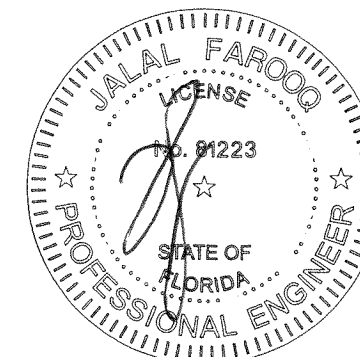

AL-FAROOQ CORPORATION
 ENGINEERS & PRODUCT DEVELOPMENT
 9360 SUNSET DRIVE, SUITE 220
 MIAMI, FLORIDA 33173
 TEL. (305) 264-8100 FAX. (305) 262-6978
 (C.A.N. 353B)

ES-H340 THERMAL ALUM SINGLE HUNG WDW. (L.M.I.)
E.S. WINDOWS, LLC
 3550 N.W. 49 STREET
 MIAMI, FL. 33142
 TEL. (305) 638-5151 FAX. (305) 638-5158

no	date	description
A	05.21.15	REV PER RER COMMENTS
B	11.01.17	GENERAL REVISION
C	03.06.24	GENERAL REVISION

date: 10-10-14
 scale: 1/2" = 1"
 dr. by: TARIQ
 chk. by:

drawing no.
W14-39
 sheet 9 of 11

COMP-ANL\W14-39-ESW

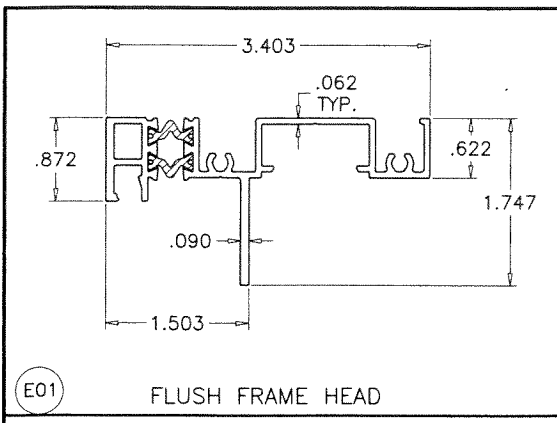

E01 FLUSH FRAME HEAD

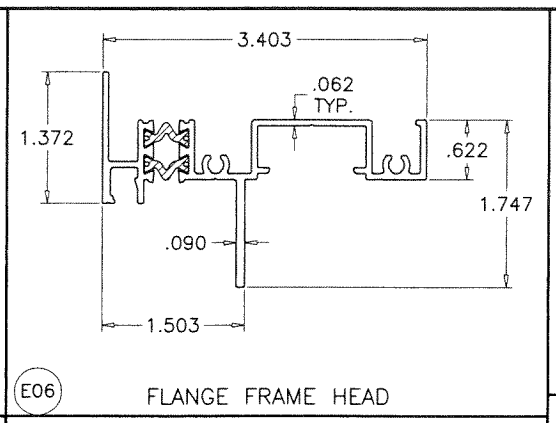

E06 FLANGE FRAME HEAD

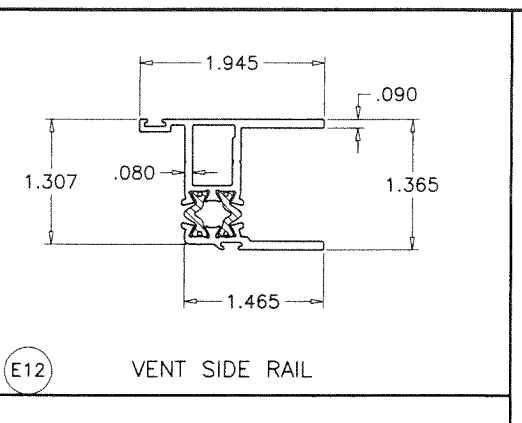

E12 VENT SIDE RAIL

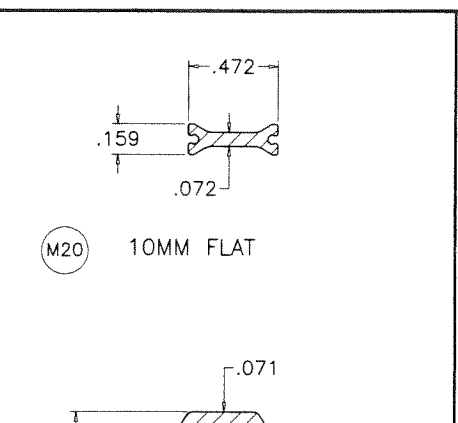

M20 10MM FLAT

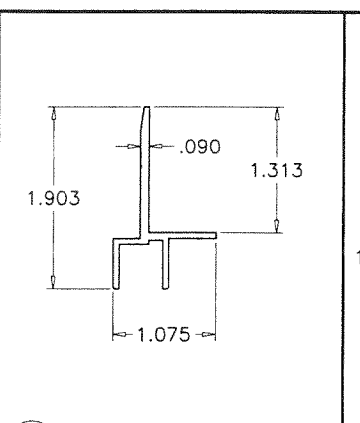

E15 NAIL FIN (HEAD)

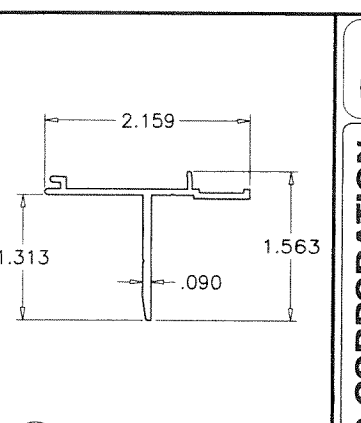

E16 NAIL FIN (SILL/JAMB)

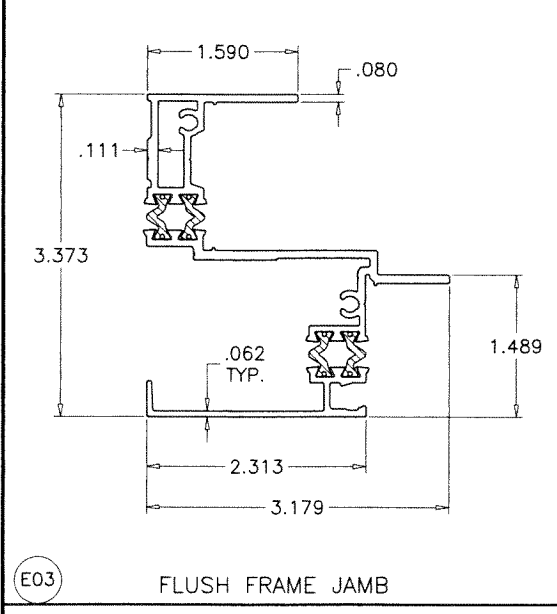

E03 FLUSH FRAME JAMB

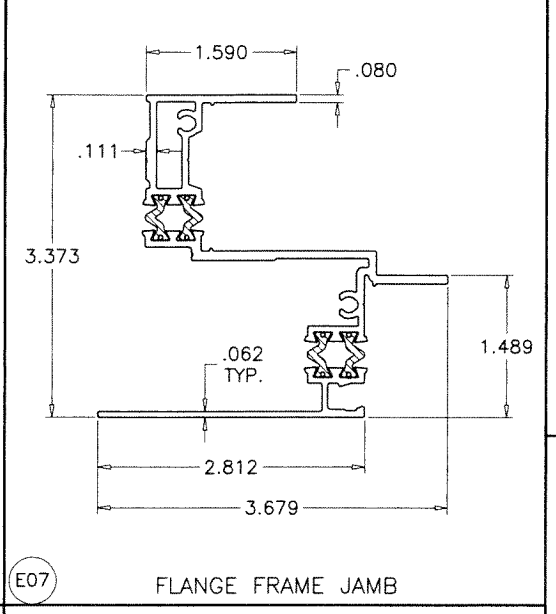

E07 FLANGE FRAME JAMB

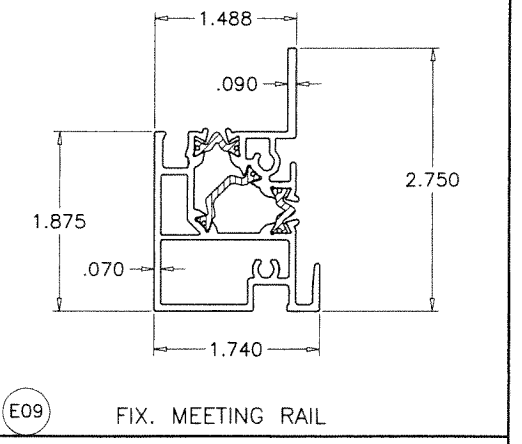

E09 FIX. MEETING RAIL

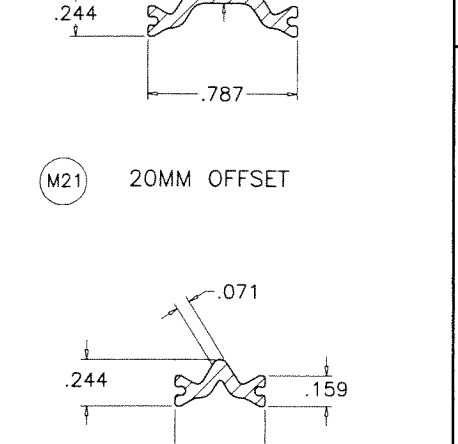

M21 20MM OFFSET

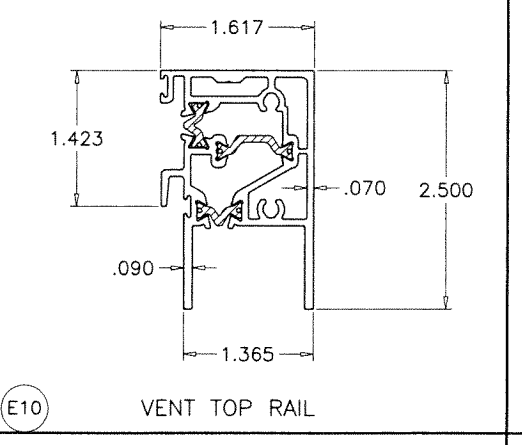

E10 VENT TOP RAIL

M22 12MM OFFSET

TECATHERM® 66 GF INSULBARS
SCALE 1:1

MATERIAL = POLYAMIDE
TENSILE STRENGTH = 13031 PSI
RATE OF BURN = .752 IN./MIN.
SELF IGNITION TEMP. = 793° F
FLASH IGNITION TEMP. = 781°C
SMOKE DENSITY = 1.63

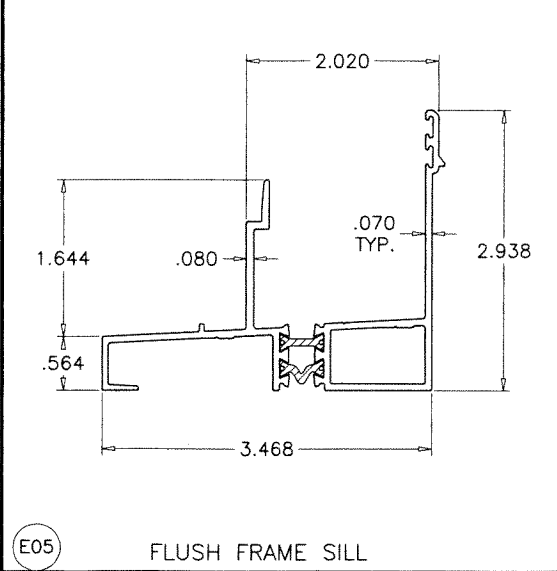

E05 FLUSH FRAME SILL

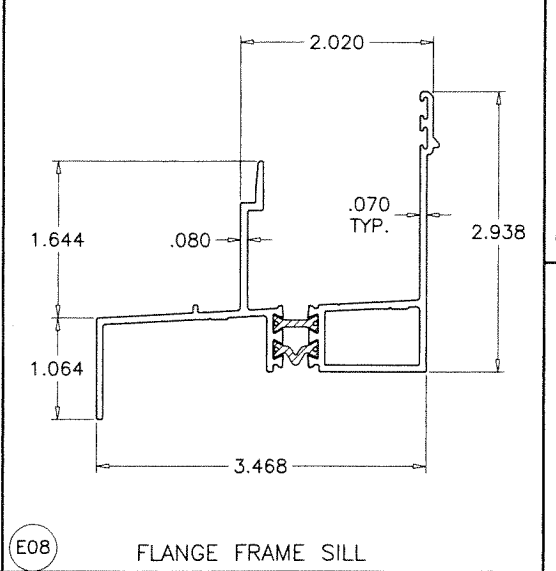

E08 FLANGE FRAME SILL

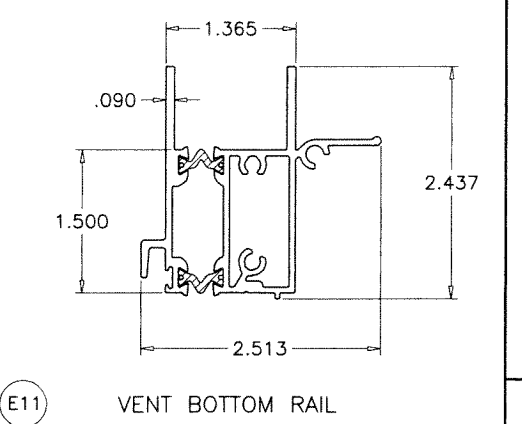

E11 VENT BOTTOM RAIL

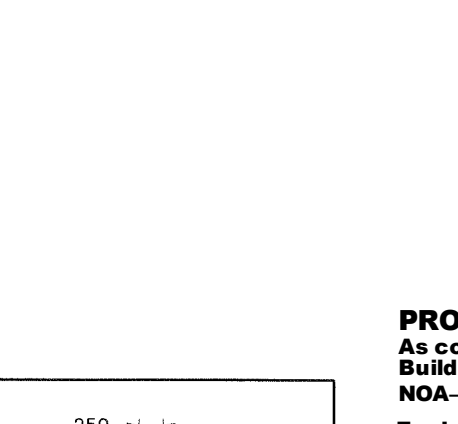

M22 12MM OFFSET

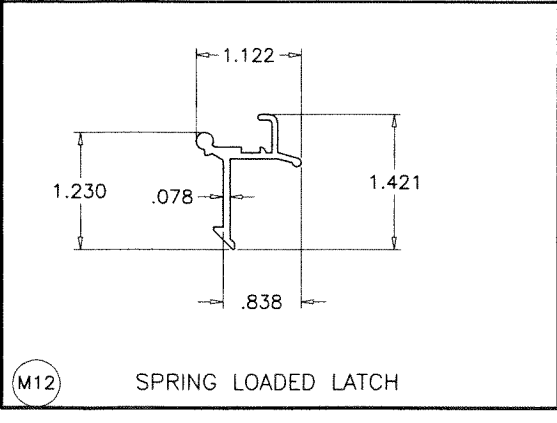

M12 SPRING LOADED LATCH

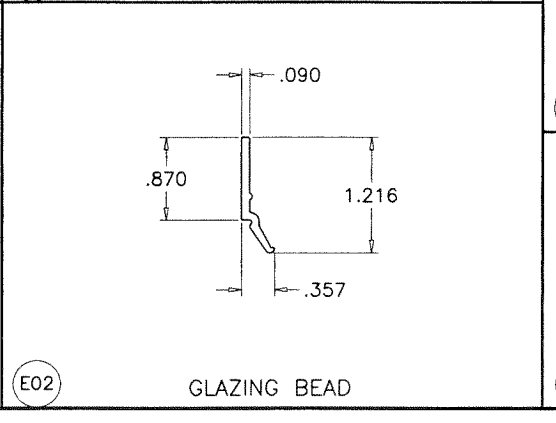

E02 GLAZING BEAD

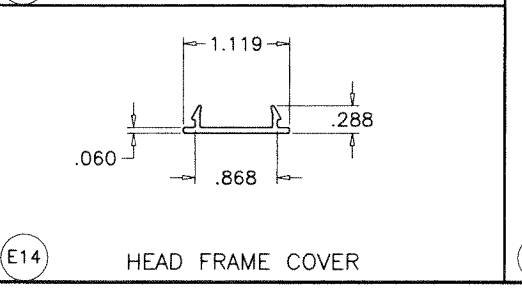

E14 HEAD FRAME COVER

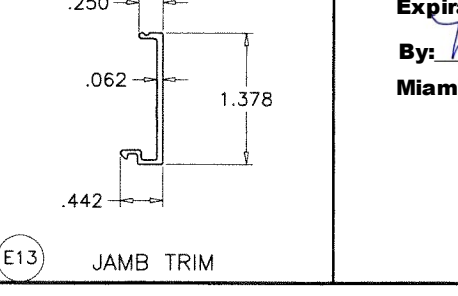

E13 JAMB TRIM

PRODUCT REVISED
As complying with the Florida Building Code
NOA-No. **24-0425.01**
Expiration Date: **06/25/2025**
By: *Manuel Ferrer*
Miami-Dade Product Control

APR 23 2024

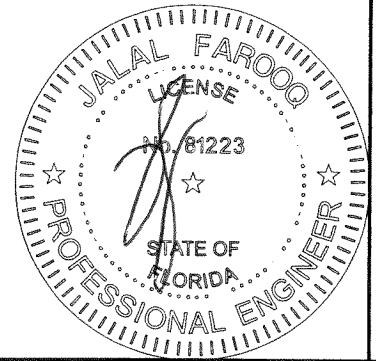

af c
AL-FAROOQ CORPORATION
ENGINEERS & PRODUCT DEVELOPMENT
9360 SUNSET DRIVE, SUITE 220
MIAMI, FLORIDA 33173
TEL. (305) 264-8100 FAX. (305) 262-6978
COMP-ANL\W14-39-ESW

ES-H340 THERMAL ALUM SINGLE HUNG WDW. (L.M.I.)
E.S. WINDOWS, LLC
3550 N.W. 49 STREET
MIAMI, FL. 33142
TEL. (305) 638-5151 FAX. (305) 638-5158

no.	date	by	description
A	05.21.15		REV. PER RER COMMENTS
B	11.01.17		GENERAL REVISION
C	03.06.24		GENERAL REVISION

date: 10-10-14
scale: 1/2" = 1"
dr. by: TARIQ
chk. by:

drawing no.
W14-39
sheet 10 of 11

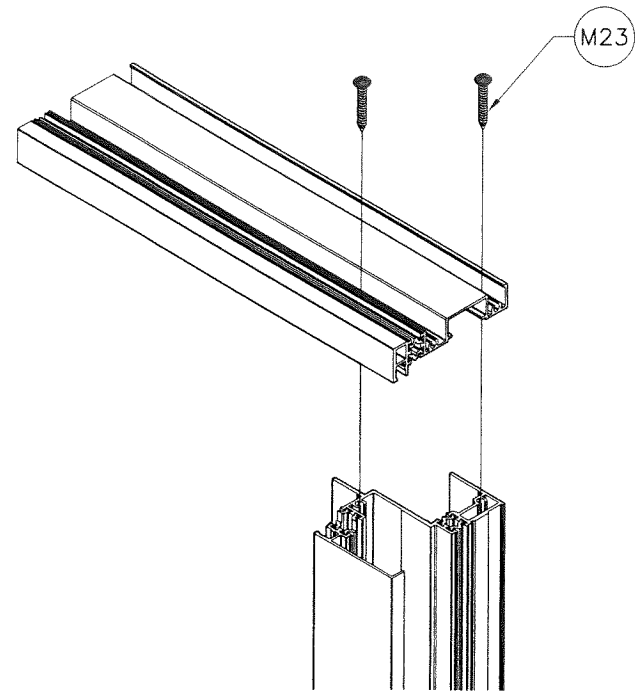

FRAME TOP CORNER

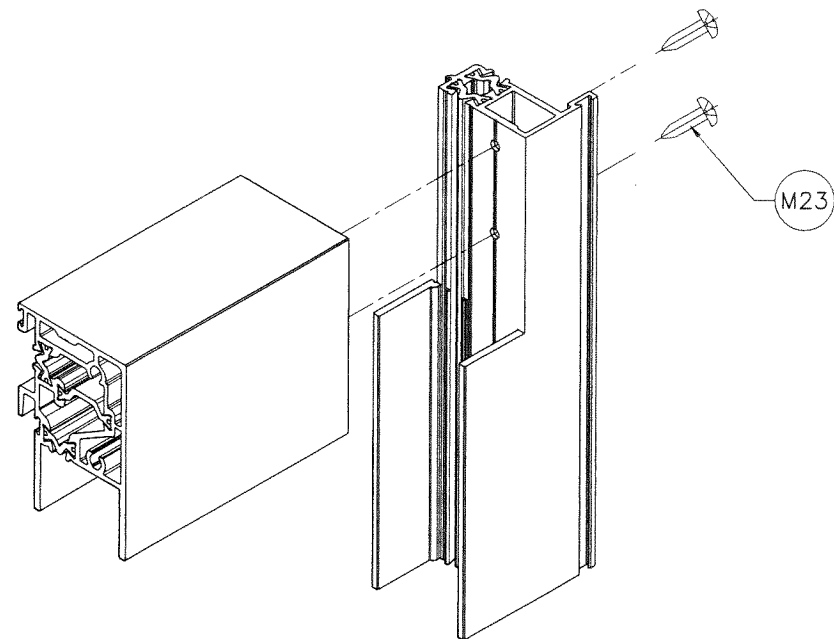

VENT TOP CORNER

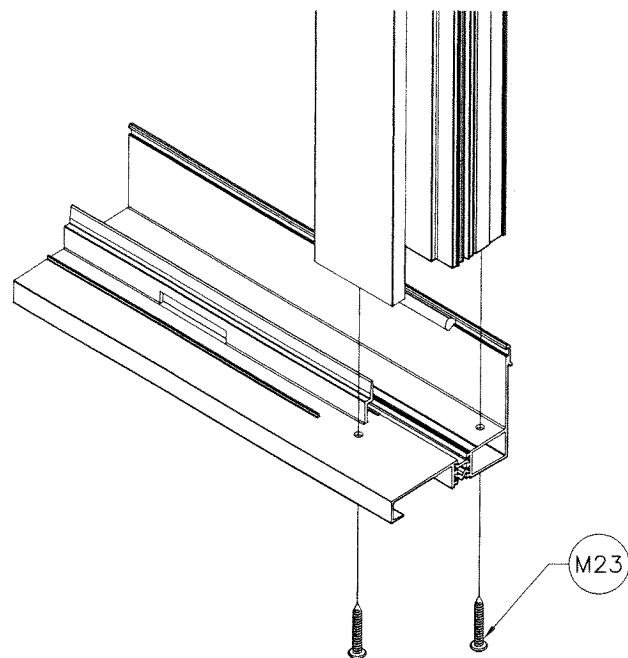

FRAME BOTTOM CORNER

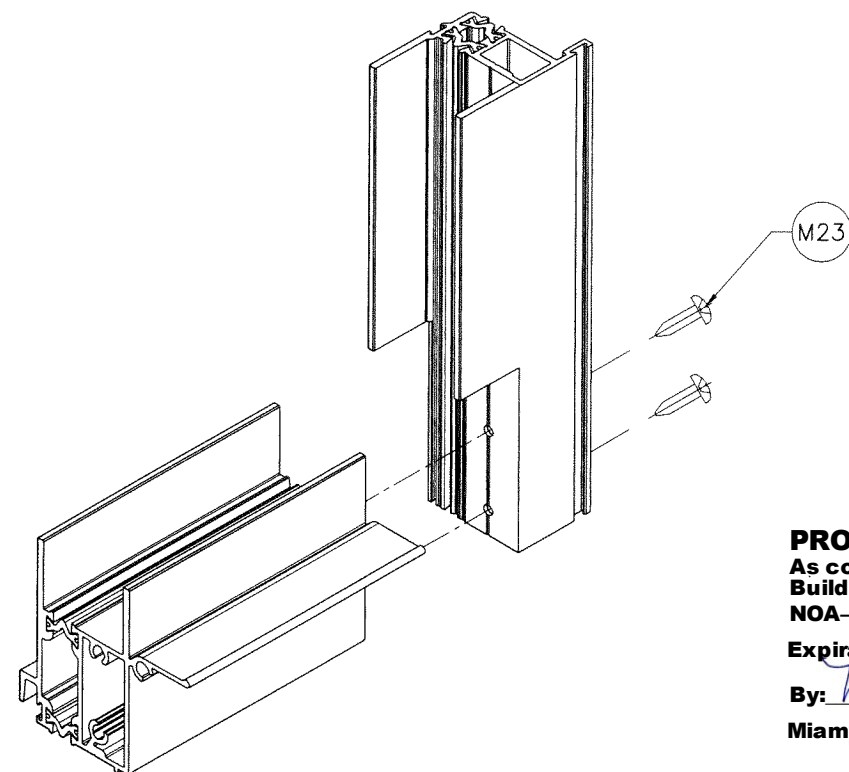

VENT BOTTOM CORNER

PRODUCT REVISED
 As complying with the Florida
 Building Code
 NOA-No. **24-0425.01**
 Expiration Date: **06/25/2025**
 By: *Manuel Ferrer*
 Miami-Dade Product Control
APR 23 2024

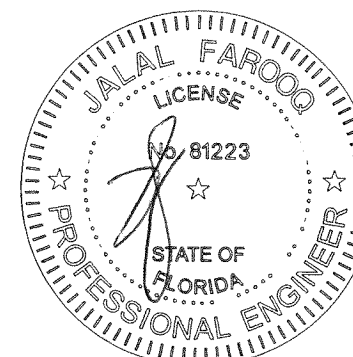

afc
AL-FAROOQ CORPORATION
 ENGINEERS & PRODUCT DEVELOPMENT
 9360 SUNSET DRIVE, SUITE 220
 MIAMI, FLORIDA 33173 (C.A.N. 3538)
 TEL. (305) 264-8100 FAX. (305) 262-6978
 COMP-ANL\W14-39-ESW

ES-H340 THERMAL ALUM SINGLE HUNG WDW. (L.M.I.)
E.S. WINDOWS, LLC
 3550 N.W. 49 STREET
 MIAMI, FL. 33142
 TEL. (305) 638-5151 FAX. (305) 638-5158

no	date	by	description
A	05.21.15	REV. PER	COMMENTS
B	11.01.17	GENERAL	REVISION
C	03.06.24	GENERAL	REVISION

date: 10-10-14
 scale: 1/2" = 1"
 dr. by: TARIQ
 chk. by:

drawing no.
W14-39
 sheet 11 of 11