



DEPARTMENT OF REGULATORY AND ECONOMIC RESOURCES (RER)
BOARD AND CODE ADMINISTRATION DIVISION

NOTICE OF ACCEPTANCE (NOA)

MIAMI-DADE COUNTY
PRODUCT CONTROL SECTION

11805 SW 26 Street, Room 208
Miami, Florida 33175-2474
T (786)315-2590 F (786) 315-2599

www.miamidade.gov/economy

The Quikrete Companies, LLC.
5 Concourse Parkway, Suite 1900
Atlanta, GA. 30328

SCOPE:

This NOA is being issued under the applicable rules and regulations governing the use of construction materials. The documentation submitted has been reviewed and accepted by Miami-Dade County RER -Product Control Section to be used in Miami Dade County and other areas where allowed by the Authority Having Jurisdiction (AHJ).

This NOA shall not be valid after the expiration date stated below. The Miami-Dade County Product Control Section (In Miami Dade County) and/or the AHJ (in areas other than Miami Dade County) reserve the right to have this product or material tested for quality assurance purposes. If this product or material fails to perform in the accepted manner, the manufacturer will incur the expense of such testing and the AHJ may immediately revoke, modify, or suspend the use of such product or material within their jurisdiction. RER reserves the right to revoke this acceptance, if it is determined by Miami-Dade County Product Control Section that this product or material fails to meet the requirements of the applicable building code.

This product is approved as described herein, and has been designed to comply with the Florida Building Code including the High Velocity Hurricane Zone of the Florida Building Code.

DESCRIPTION: QUIKRETE® Roof Tile Mortar FL-15

LABELING: Each unit shall bear a permanent label with the manufacturer's name or logo, city, state and following statement: "Miami-Dade County Product Control Approved", unless otherwise noted herein.

RENEWAL of this NOA shall be considered after a renewal application has been filed and there has been no change in the applicable building code negatively affecting the performance of this product.

TERMINATION of this NOA will occur after the expiration date or if there has been a revision or change in the materials, use, and/or manufacture of the product or process. Misuse of this NOA as an endorsement of any product, for sales, advertising or any other purposes shall automatically terminate this NOA. Failure to comply with any section of this NOA shall be cause for termination and removal of NOA.

ADVERTISEMENT: The NOA number preceded by the words Miami-Dade County, Florida, and followed by the expiration date may be displayed in advertising literature. If any portion of the NOA is displayed, then it shall be done in its entirety.

INSPECTION: A copy of this entire NOA shall be provided to the user by the manufacturer or its distributors and shall be available for inspection at the job site at the request of the Building Official.

This NOA renews NOA# 19-0226.08 and consists of pages 1 through 6.
The submitted documentation was reviewed by Alex Tigera.

01/02/25



NOA No.: 24-0723.01
Expiration Date: 11/06/29
Approval Date: 01/02/25
Page 1 of 6

ROOFING COMPONENT APPROVAL:

Category: Roofing
Sub Category: Roofing Tile Adhesives
Materials: Cement

SCOPE:

This approves **QUIKRETE® Roof Tile Mortar FL-15** as manufactured by The Quikrete Companies, LLC. as described in this Notice of Acceptance.

PRODUCTS MANUFACTURED BY OR LABELED BY APPLICANT:

<u>Product</u>	<u>Dimensions</u>	<u>Test Specifications</u>	<u>Product Description</u>
QUIKRETE® Roof Tile Mortar FL-15	80 lb. bags	TAS 123	Premixed pre-bagged gray roof tile mortar for use with approved roof tiles in accordance with RAS 120

MANUFACTURING LOCATIONS:

1. Miami, FL
2. Lakeland, FL
3. Jacksonville, FL
4. Ft. Myers, FL.

EVIDENCE SUBMITTED:

<u>Test Agency</u>	<u>Test Identifier</u>	<u>Test Name/Report</u>	<u>Date</u>
Center for Applied Engineering	Metro Dade Protocol TAS 101		
Florida Testing and Engineering, Inc.	ASTM C 91 Type M		
PRI Construction Materials Technologies	TAS 123 TAS 123 TAS 123	QKT-003-02-01 QKT-004-02-02INT QKT-007-02-01	10/15/09 10/23/14 06/26/15
Construction Technology Laboratories, Inc.	ASTM C 270	385045	06/14/10



NOA No.: 24-0723.01
Expiration Date: 11/06/29
Approval Date: 01/02/25
Page 2 of 6

LIMITATIONS:

1. Fire classification is not part of this acceptance. Refer to the Prepared Roof Tile Assembly for fire rating.
2. Field uplift testing shall be performed, in accordance with the test procedures set forth in Roofing Application Standard TAS 106. Testing shall be performed not prior to 30 days after installation.
3. Quikrete® Roof Tile Mortar FL – 15 shall be placed in a 5" x 12" pad at time of application. The mortar pad placement shall be in accordance with the 'Placement Details' provided herein. Each generic tile profile requires a specific placement, (see Placement Detail listed herein).
4. Quikrete® Roof Tile Mortar FL - 15 shall be applied in accordance with The Quikrete Companies, LLC's specifications.
5. Tile must be applied within 5 minutes of the application of Quikrete® Roof Tile Mortar. FL – 15.
6. Refer to the tile manufacturer's Miami-Dade County Product Control Notice of Acceptance for system approvals.
7. All products listed herein shall have a quality assurance audit in accordance with the Florida Building Code and Rule 61G20-3 of the Florida Administrative Code.
5. All bags shall be labeled and shall bear the imprint or identifiable marking of the manufacturer's name or logo, city and state of manufacturing facility, and following statement: "Miami-Dade County Product Control Approved" or the Miami-Dade County Product Control Seal as shown below.



INSTALLATION:

1. Quikrete® Roof Tile Mortar FL - 15 and its components shall be installed in strict compliance with Roofing Application Standard RAS 120.
2. Mortar placement shall be in accordance with the placement details specified below.

PLACEMENT DETAILS	
TILE PROFILE:	DETAIL NO.
Medium Profile	A
Flat Profile	B
High Profile	C

BUILDING PERMIT REQUIREMENTS:

1. As required by the Building Official or applicable building code in order to properly evaluate the installation of this system.



PLACEMENT DETAIL "A"

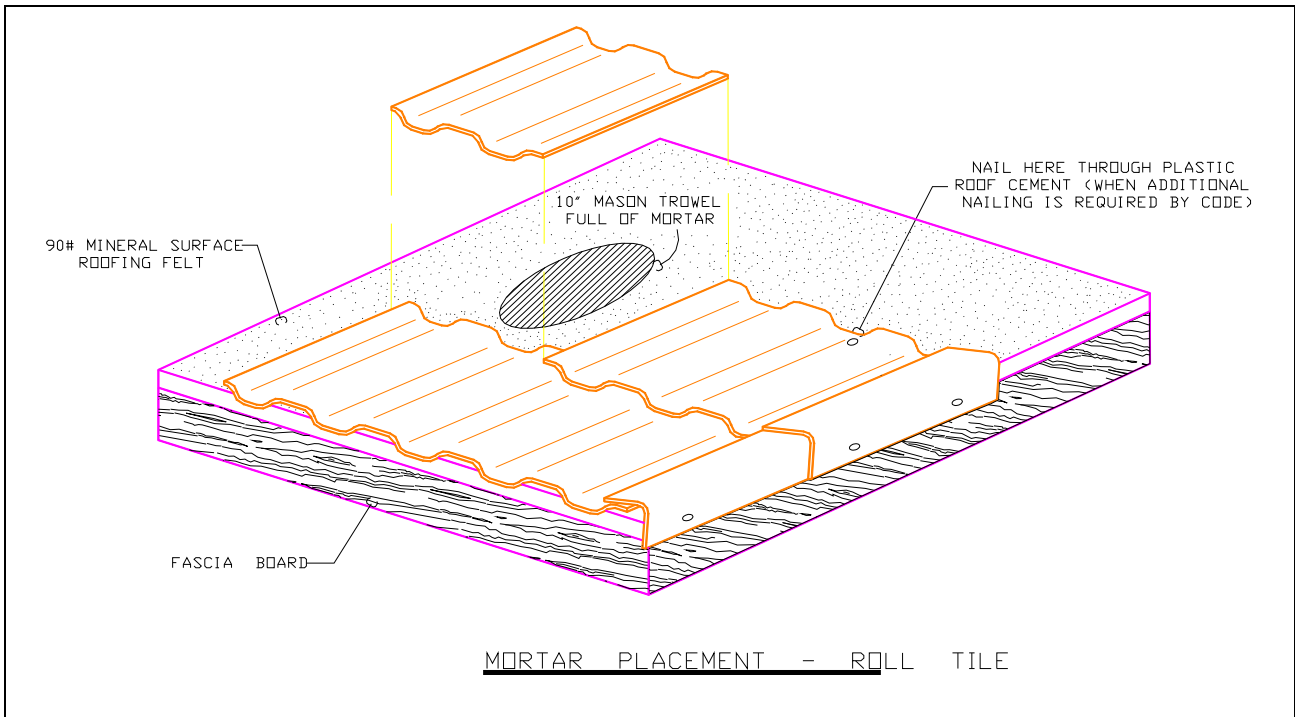

PLACEMENT DETAIL "B"

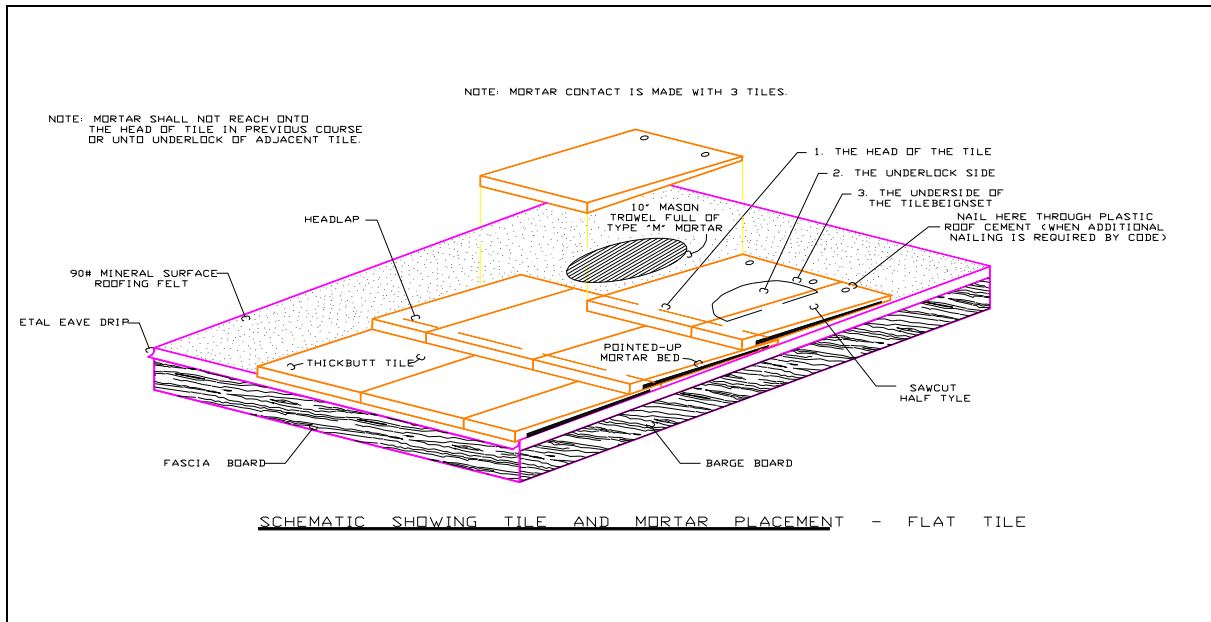

PLACEMENT DETAIL "C"



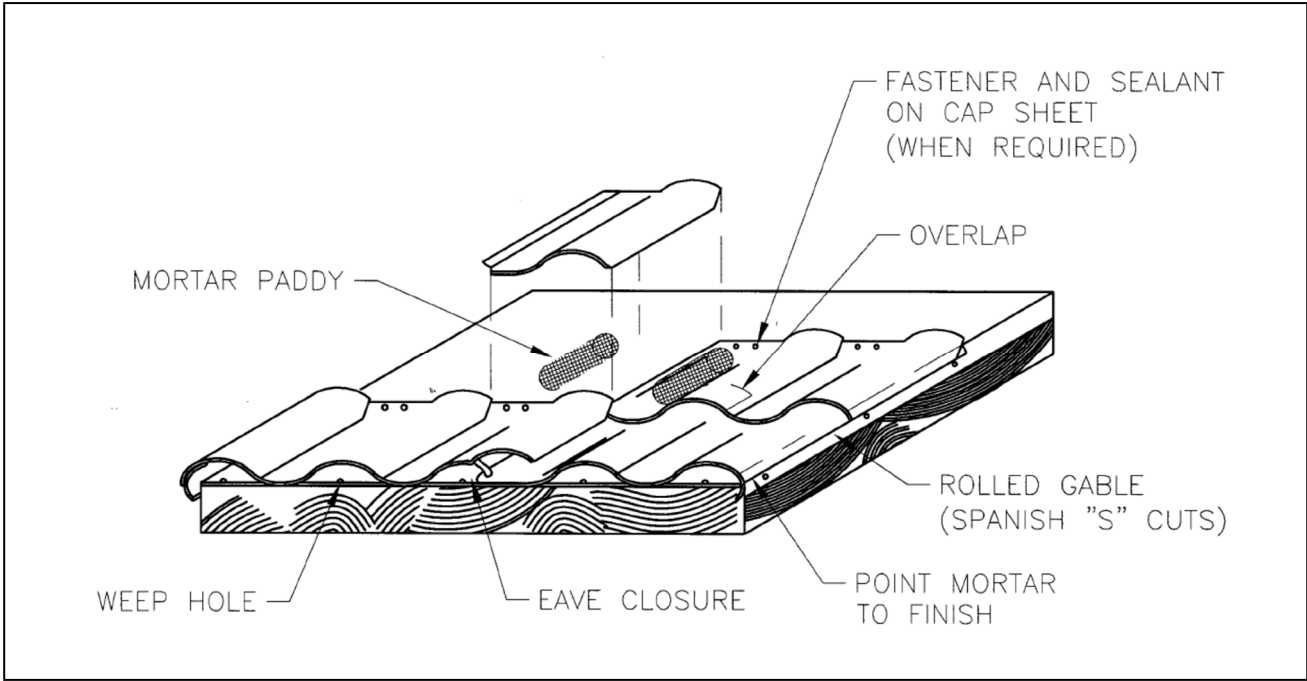

PLACEMENT DETAIL "C" (CONTINUED)

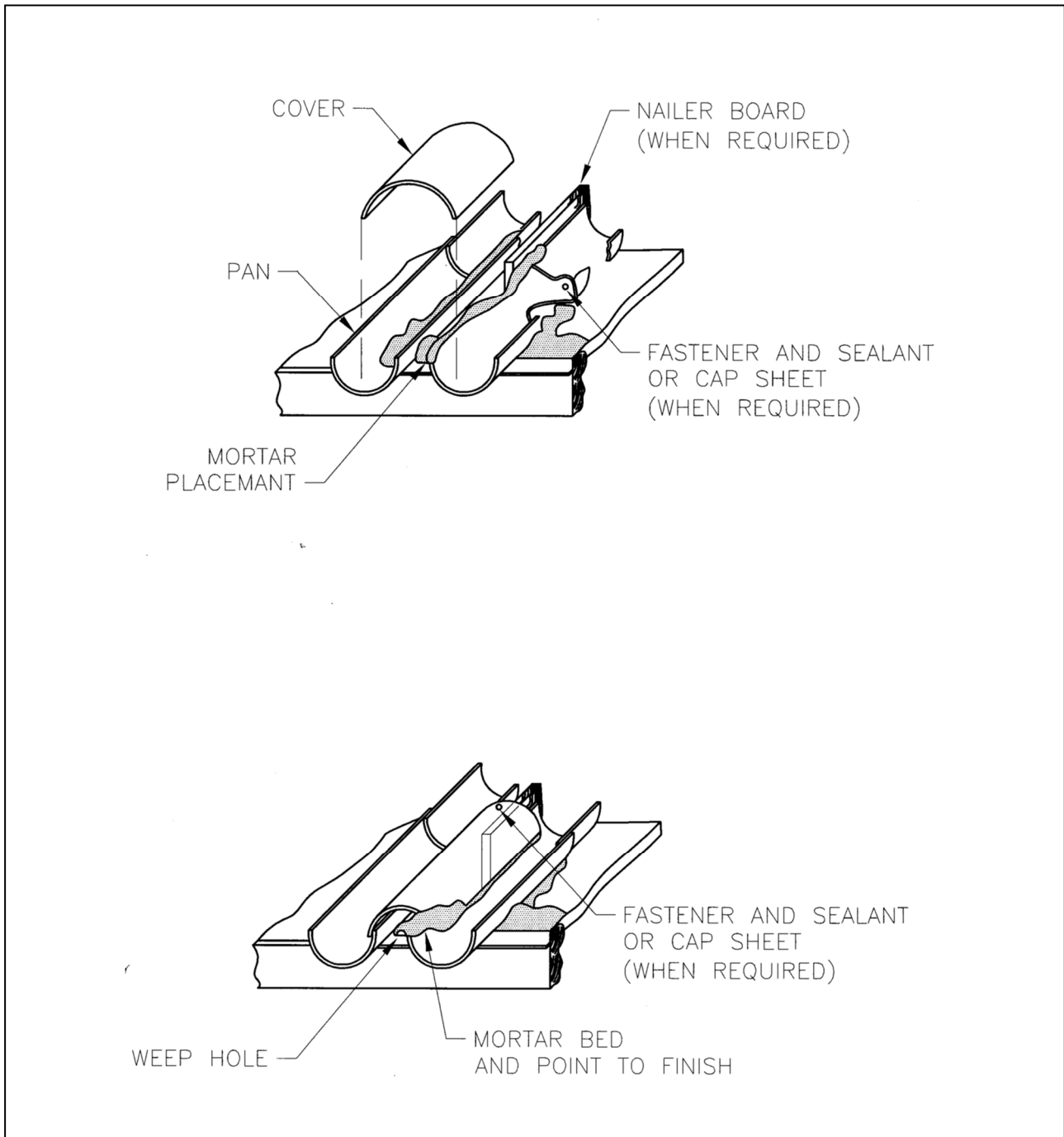

END OF THIS ACCEPTANCE



NOA No.: 24-0723.01
Expiration Date: 11/06/29
Approval Date: 01/02/25
Page 6 of 6