



MIAMI-DADE COUNTY  
**PRODUCT CONTROL SECTION**  
 11805 SW 26 Street, Room 208  
 Miami, Florida 33175-2474  
 T (786) 315-2590 F (786) 315-2599

DEPARTMENT OF REGULATORY AND ECONOMIC RESOURCES (RER)  
 BOARD AND CODE ADMINISTRATION DIVISION  
**NOTICE OF ACCEPTANCE (NOA)**

[www.miamidade.gov/building](http://www.miamidade.gov/building)

**E.S. Windows, LLC**  
**3550 NW 49<sup>th</sup> Street**  
**Miami, FL 33142**

**SCOPE:**

This NOA is being issued under the applicable rules and regulations governing the use of construction materials. The documentation submitted has been reviewed and accepted by Miami-Dade County RER-Product Control Section to be used in Miami-Dade County and other areas where allowed by the Authority Having Jurisdiction (AHJ).

This NOA shall not be valid after the expiration date stated below. The Miami-Dade County Product Control Section (In Miami-Dade County) and/ or the AHJ (in areas other than Miami-Dade County) reserve the right to have this product or material tested for quality assurance purposes. If this product or material fails to perform in the accepted manner, the manufacturer will incur the expense of such testing and the AHJ may immediately revoke, modify, or suspend the use of such product or material within their jurisdiction. RER reserves the right to revoke this acceptance if it is determined by Miami-Dade County Product Control Section that this product or material fails to meet the requirements of the applicable building code.

This product is approved as described herein and has been designed to comply with the Florida Building Code, including the High Velocity Hurricane Zone.

**DESCRIPTION: Series “ES-P252 Thermally Broken” Outswing Aluminum Casement Window – S.M.I.**

**APPROVAL DOCUMENT:** Drawing No. **W16-45**, titled “ES-P252 Thermal Alum Casement Wdw. (S.M.I)”, sheets 1, 1.1, 2 and 3 through 8 of 8, dated 06/01/16, with revision **G** dated 10/02/24, prepared by Al-Farooq Corporation, signed and sealed by Jalal Farooq, P.E., bearing the Miami-Dade County Product Control Revision stamp with the Notice of Acceptance number and expiration date by the Miami-Dade County Product Control Section.

**MISSILE IMPACT RATING: Small Missile Impact Resistant**

**LABELING:** Each unit shall bear a permanent label with the manufacturer's name or logo, **Barranquilla, Colombia**, model/series, and following statement: "Miami-Dade County Product Control Approved", unless otherwise noted herein.

**RENEWAL** of this NOA shall be considered after a renewal application has been filed and there has been no change in the applicable building code negatively affecting the performance of this product.

**TERMINATION** of this NOA will occur after the expiration date or if there has been a revision or change in the materials, use, and/ or manufacture of the product or process. Misuse of this NOA as an endorsement of any product, for sales, advertising or any other purposes shall automatically terminate this NOA. Failure to comply with any section of this NOA shall be cause for termination and removal of NOA.

**ADVERTISEMENT:** The NOA number preceded by the words Miami-Dade County, Florida, and followed by the expiration date may be displayed in advertising literature. If any portion of the NOA is displayed, then it shall be done in its entirety.

**INSPECTION:** A copy of this entire NOA shall be provided to the user by the manufacturer or its distributors and shall be available for inspection at the job site at the request of the Building Official.

This NOA **revises NOA No. 23-0717.24** and consists of this page 1 and evidence pages E-1, E-2, E-3, E-4 and E-5, as well as approval document mentioned above.

The submitted documentation was reviewed by **Manuel Perez, P.E.**



  
 11/15/24

**NOA No. 24-1007.07**  
**Expiration Date: December 22, 2026**  
**Approval Date: November 21, 2024**  
 Page 1

NOTICE OF ACCEPTANCE: EVIDENCE SUBMITTED

**1. EVIDENCE SUBMITTED UNDER PREVIOUS NOA's**

**A. DRAWINGS**

1. Manufacturer's die drawings and sections.  
*(Submitted under NOA No. 15-0305.04)*
2. Drawing No. **W16-45**, titled "ES-P252 Thermal Alum Casement Wdw. (S.M.I)", sheets 1, 1.1, 2 and 3 through 8 of 8, dated 06/01/16, with revision F dated 06/29/23, prepared by Al-Farooq Corporation, signed and sealed by Jalal Farooq, P.E.  
*(Submitted under NOA No. 23-0717.24)*

**B. TESTS**

1. Test reports on: 1) Air Infiltration Test, per FBC, TAS 202-94  
2) Uniform Static Air Pressure Test, Loading per FBC TAS 202-94  
3) Water Resistance Test, per FBC, TAS 202-94  
4) Large Missile Impact Test per FBC, TAS 201-94  
5) Small Missile Impact Test per FBC, TAS 201-94  
6) Cyclic Wind Pressure Loading per FBC, TAS 203-94  
7) Forced Entry Test, per ASTM F 588-04/ 07 and per FBC 2411 3.2.1, TAS 202-94  
along with marked-up drawings and installation diagram of a series ES-P252 aluminum casement window samples A-1, B-1, C-1, D-1, E-1, F-1, G-1, H-1, I-1, J-1, K-1, K-2, K-3 and L-1, prepared by Fenestration Testing Laboratory, Inc., Test Report No. **FTL-12064**, dated 07/16/20, signed and sealed by Idalmis Ortega, P.E.  
*(Submitted under NOA No. 20-1118.05)*
2. Test reports on: 1) Air Infiltration Test, per FBC, TAS 202-94  
2) Uniform Static Air Pressure Test, Loading per FBC TAS 202-94  
3) Water Resistance Test, per FBC, TAS 202-94  
4) Large Missile Impact Test per FBC, TAS 201-94  
5) Small Missile Impact Test per FBC, TAS 201-94  
6) Cyclic Wind Pressure Loading per FBC, TAS 203-94  
7) Forced Entry Test, per ASTM F 588-04/ 07 and per FBC 2411 3.2.1, TAS 202-94  
along with marked-up drawings and installation diagram of aa aluminum casement window samples A-1, A-2, A-3, B-1, B-2 and B-3, prepared by Fenestration Testing Laboratory, Inc., Test Report No. **FTL-7798**, dated 10/09/15, signed and sealed by Idalmis Ortega, P.E.  
*(Submitted under NOA No. 15-0305.04)*

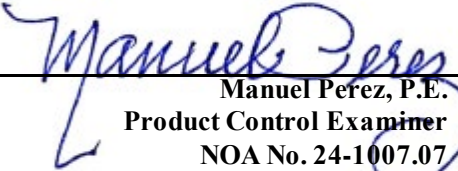
  
Manuel Perez, P.E.  
Product Control Examiner  
NOA No. 24-1007.07  
Expiration Date: December 22, 2026  
Approval Date: November 21, 2024

NOTICE OF ACCEPTANCE: EVIDENCE SUBMITTED

**1. EVIDENCE SUBMITTED UNDER PREVIOUS NOA's (CONTINUED)**

**C. CALCULATIONS**

1. Anchor verification calculations and structural analysis, complying with **FBC 5<sup>th</sup> Edition (2014)**, dated 06/20/16, revised on 08/01/16, and further updated on 08/07/20 to comply with **FBC 7<sup>th</sup> Edition (2020)**, prepared by Al-Farooq Corporation, signed and sealed by Jalal Farooq, P.E.  
*(Submitted under NOA No. 20-1118.05)*
2. Glazing complies with **ASTM E1300-09**

**D. QUALITY ASSURANCE**

1. Miami-Dade Department of Regulatory and Economic Resources (RER).

**E. MATERIAL CERTIFICATIONS**

1. Notice of Acceptance No. **20-0915.22** issued to **Kuraray America, Inc.** for their “**Trosifol® Ultraclear, Clear and Color PVB Glass Interlayers**” dated 11/19/20, expiring on 07/08/24.
2. Notice of Acceptance No. **21-0216.01** issued to **Eastman Chemical Company (MA)** for their “**Saflex PVB Interlayers - Clear and Colored for Glass**” dated 04/29/21, expiring on 05/21/26.
3. 0.315-inch (Length) by 0.26-inch (Height) by 0.0059-inch (Thickness) (8x6.6x0.15mm) Aluminum Low Profile Insulated-Glass spacer **Helima AH 800 N** (P/N.: USA K 001 000 000 R7) with Aluminum Alloy **AW-3000** ( $F_{tu}=17$  ksi and  $F_{ty}=12$ ksi) by **Helmut Lingemann GmbH & Co., KG.** (Helima).
4. Ensinger, GmbH Part No. **Tecatherm 66 GF Insulbar** complying with ASTM D638 Tensile Strength of 13,031 psi, ASTM D 1929 Self Ignition 793°F and Flash Ignition – 781°F, ASTM D 2843 Smoke Density of 1.63, ASTM D 635 Rate of Burn 0.752 in./min., ASTM D 790 Flexural Modulus of 870 ksi, ASTM D 256 Notched Izod of 1.9 ft.-lb./in.

  
Manuel Pérez, P.E.  
Product Control Examiner  
NOA No. 24-1007.07  
Expiration Date: December 22, 2026  
Approval Date: November 21, 2024

NOTICE OF ACCEPTANCE: EVIDENCE SUBMITTED

**1. EVIDENCE SUBMITTED UNDER PREVIOUS NOA's (CONTINUED)**

**E. MATERIAL CERTIFICATIONS (CONTINUED)**

5. Test Report No. **ATI-60520.02-106-18**, prepared by Architectural Testing, Inc., dated 11/09/06, with revision date 11/29/06, issued to **Ensinger, Inc.**, for their **Tecatherm® 66GF Insulbar material** comprised of Polyamide 66 with 25% glass fibers, per **ASTM G 155-00ae1**, "*Standard Practice for Operating Xenon Arc Light Apparatus for Exposure of/Non-Metallic Materials*", per **ASTM D638-03** "*Standard Test Methods for Tensile Properties of Plastics*", for exposed & unexposed sample per Xenon Arc after 4500 Hours, **ASTM D635-98** "*Standard Test Method for Rate of Burning and/or Extent and Time of Burning of Plastics in a Horizontal Position*", **ASTM D1929-96** (2000)e01 "*Standard Test Method for Determining Ignition Properties of Plastics*" and **ASTM D2843-99** "*Standard Test Method for Density of Smoke from the Burning or Decomposition of Plastics*" and **ASTM D2843-99** "*Standard Test Method for Density of Smoke from the Burning or Decomposition of Plastics*", signed and sealed by Joseph A. Reed, P.E.
6. Standard Material Values Data Sheet from **Ensinger** for "**Tecatherm 66 GF** Polyamide 66 with 25% glass fibers, black– Mechanical Properties and Thermal Properties.

**F. STATEMENTS**

1. Statement letter of conformance, complying with **FBC 7<sup>th</sup> Edition (2020)**, with **FBC 8<sup>th</sup> Edition (2023)**, and of no financial interest, dated July 14, 2023, issued by Al-Farooq Corporation, signed and sealed by Jalal Farooq, P.E. (*Submitted under NOA No. 23-0717.24*)
2. Distributor Agreement between ES Windows–Energia Solar, S.A., Barranquilla, Columbia, S.A. and E.S. Windows, LLC, Miami, Florida, dated 09/12/13, signed by Ms. Adriana Montoya, Manager and Andres Chamorro, General Manager respectively on behalf of the companies. (*Submitted under NOA No. 15-0305.04*)
3. Laboratory compliance letter for Test Report No. **FTL-7798**, issued by Fenestration Testing Laboratory, Inc., dated 04/14/16, signed and sealed by Idalmis Ortega, P.E. (*Submitted under NOA No. 15-0305.04*)
4. Proposal issued by Product Control, dated 10/18/12, signed by Jaime D. Gascon, P.E. (*Submitted under NOA No. 15-0305.04*)

**G. OTHERS**

1. Notice of Acceptance No. **20-1118.05**, issued to E.S. Windows, LLC for their Series "ES-P252 Thermally Broken" Outswing Aluminum Casement Window – S.M.I., approved on 02/11/21 and expiring on 12/22/26.

  
Manuel Pérez, P.E.  
Product Control Examiner  
NOA No. 24-1007.07  
Expiration Date: December 22, 2026  
Approval Date: November 21, 2024

NOTICE OF ACCEPTANCE: EVIDENCE SUBMITTED

**2. NEW EVIDENCE SUBMITTED**

**A. DRAWINGS**

1. Drawing No. **W16-45**, titled “ES-P252 Thermal Alum Casement Wdw. (S.M.I)”, sheets 1, 1.1, 2 and 3 through 8 of 8, dated 06/01/16, with revision **G** dated 10/02/24, prepared by Al-Farooq Corporation, signed and sealed by Jalal Farooq, P.E.

**B. TESTS**

1. Test reports on: 1) Uniform Static Air Pressure Test, Loading per FBC TAS 202-94  
2) Large Missile Impact Test per FBC, TAS 201-94  
3) Small Missile Impact Test per FBC, TAS 201-94  
4) Cyclic Wind Pressure Loading per FBC, TAS 203-94  
along with marked-up drawings and installation diagram of series ES-P252 aluminum casement window samples 1 through 6, prepared by Blackwater Technical Services, Inc., Test Report No. **BT-ESW-23-044**, dated 09/25/24, signed and sealed by Michael D. Caldwell, P.E.

**C. CALCULATIONS**

1. None.

**D. QUALITY ASSURANCE**

1. Miami-Dade Department of Regulatory and Economic Resources (RER)

**E. MATERIAL CERTIFICATIONS**

1. Notice of Acceptance No. **24-0205.08** issued to **Kuraray America, Inc.** for their “**Trosifol® Ultraclear, Clear and Color PVB Glass Interlayers**” dated 03/21/24, expiring on 07/08/29.
2. Notice of Acceptance No. **23-0713.18** issued to **Eastman Chemical Company (MA)** for their “**Saflex® PVB Clear and Colored Interlayers for Laminated Glass**” dated 08/17/23, expiring on 05/21/26.
3. Notice of Acceptance No. **23-0713.13** issued to **Chang Chun Chemical Corporation** for their “**WINLITE® PVB Film Glass Interlayer**” dated 08/17/23, expiring on 10/08/25.

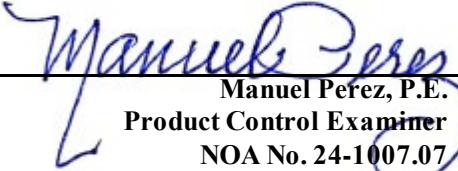
  
Manuel Perez, P.E.  
Product Control Examiner  
NOA No. 24-1007.07  
Expiration Date: December 22, 2026  
Approval Date: November 21, 2024

**E.S. Windows, LLC**

**NOTICE OF ACCEPTANCE: EVIDENCE SUBMITTED**

**2. NEW EVIDENCE SUBMITTED (CONTINUED)**

**F. STATEMENTS**

1. Statement letter of conformance, complying with **FBC 8<sup>th</sup> Edition (2023)**, and of no financial interest, dated October 1, 2024, issued by Al-Farooq Corporation, signed and sealed by Jalal Farooq, P.E.

**G. OTHERS**

1. Notice of Acceptance No. **23-0717.24**, issued to E.S. Windows, LLC for their Series “ES-P252 Thermally Broken” Outswing Aluminum Casement Window – S.M.I., approved on 08/24/23 and expiring on 12/22/26.

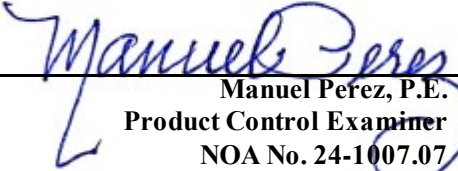
  
\_\_\_\_\_  
Manuel Pérez, P.E.  
Product Control Examiner  
NOA No. 24-1007.07  
Expiration Date: December 22, 2026  
Approval Date: November 21, 2024

**ES-P252 (S.M.I.)  
THERMAL ALUMINUM CASEMENT WINDOW**

APPROVAL APPLIES TO SINGLE UNITS OR SIDE BY SIDE COMBINATIONS OF CASMT./CASMT. OR CASEMENT WITH OTHER WINDOW TYPES IN MODULES OF TWO OR MORE WINDOWS USING MIAMI-DADE COUNTY APPROVED MULLIONS IN BETWEEN. LOWER DESIGN PRESSURE FROM WINDOWS OR MULLION APPROVAL WILL APPLY TO ENTIRE SYSTEM.

THIS PRODUCT HAS BEEN DESIGNED AND TESTED TO COMPLY WITH THE REQUIREMENTS OF THE 2023 (8TH EDITION) FLORIDA BUILDING CODE INCLUDING HIGH VELOCITY HURRICANE ZONE (HVHZ).

1BY OR 2BY WOOD BUCKS & BUCK FASTENERS BY OTHERS, MUST BE DESIGNED AND INSTALLED ADEQUATELY TO TRANSFER APPLIED PRODUCT LOADS TO THE BUILDING STRUCTURE.

ANCHORS SHALL BE CORROSION RESISTANT, SPACED AS SHOWN ON DETAILS AND INSTALLED PER MANUF'S INSTRUCTIONS. SPECIFIED EMBEDMENT TO BASE MATERIAL SHALL BE BEYOND WALL DRESSING OR STUCCO.

A LOAD DURATION INCREASE IS USED IN DESIGN OF ANCHORS INTO WOOD ONLY.

ALL SHIMS TO BE HIGH IMPACT, NON-METALLIC AND NON-COMPRESSIBLE.

MATERIALS INCLUDING BUT NOT LIMITED TO STEEL/METAL SCREWS, THAT COME INTO CONTACT WITH OTHER DISSIMILAR MATERIALS SHALL MEET THE REQUIREMENTS OF THE 2023 FLORIDA BLDG. CODE & ADOPTED STANDARDS.

THIS PRODUCT APPROVAL IS GENERIC AND DOES NOT PROVIDE INFORMATION FOR A SITE SPECIFIC PROJECT, i.e. LIFE SAFETY OF THIS PRODUCT, ADEQUACY OF STRUCTURE RECEIVING THIS PRODUCT AND SEALING AROUND OPENING FOR WATER INFILTRATION RESISTANCE ETC.

CONDITIONS NOT SHOWN IN THIS DRAWING ARE TO BE ANALYZED SEPARATELY, AND TO BE REVIEWED BY BUILDING OFFICIAL.

DESIGN LOADS SHOWN ARE BASED ON 'ALLOWABLE STRESS DESIGN (ASD)'.

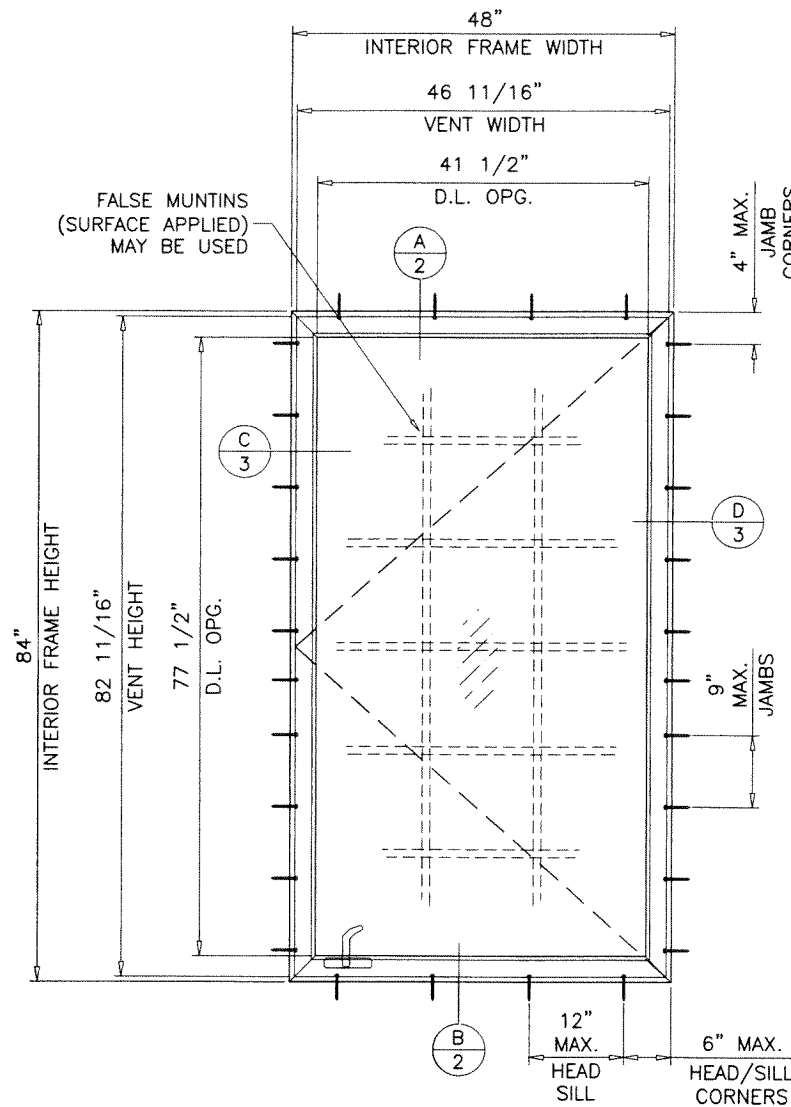

**TYPICAL ELEVATION**  
ANCHORS THRU WDW. FRAMES

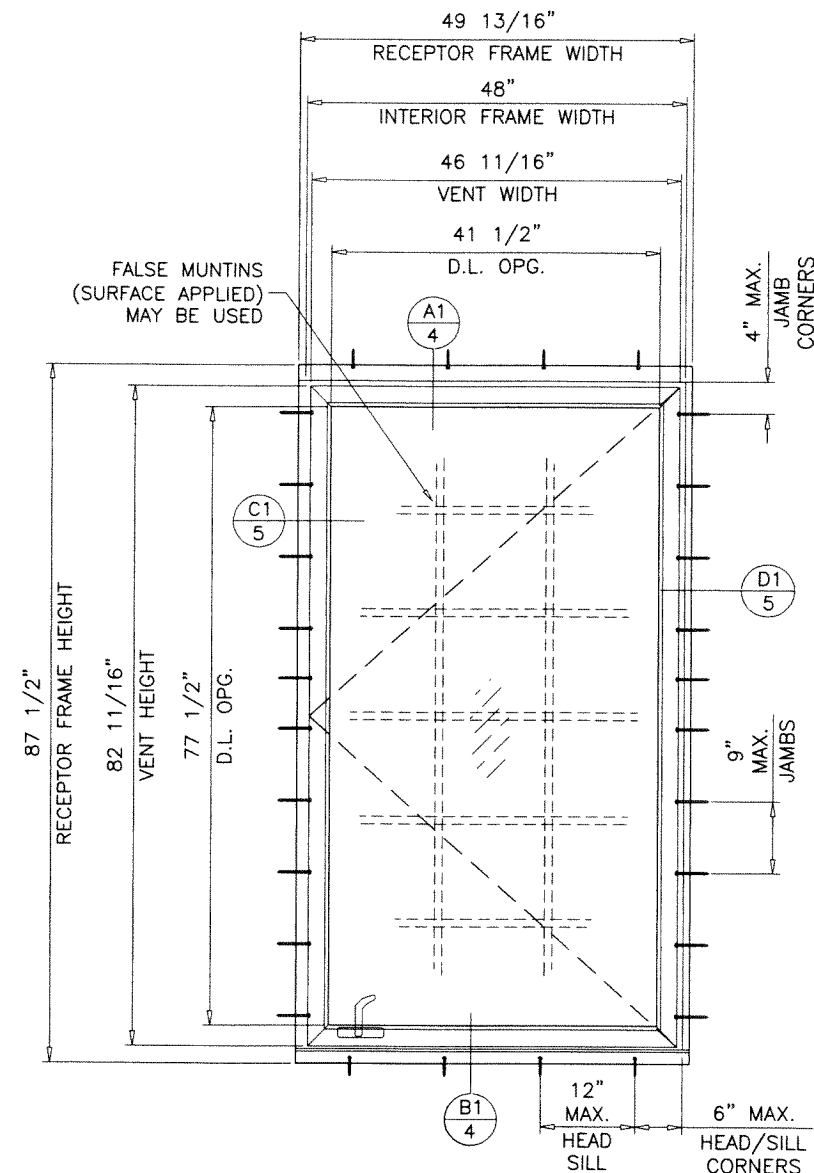

**TYPICAL ELEVATION**  
ANCHORS THRU RECEPTOR FRAMES

THESE WINDOWS ARE RATED FOR SMALL MISSILE IMPACT. MIAMI-DADE COUNTY APPROVED IMPACT RESISTANT SHUTTERS REQUIRED FOR INSTALLATIONS UP TO 30 FT. OF GRADE. SHUTTERS NOT REQD. FOR INSTALLATIONS ABOVE 30 FT. OF GRADE.

**PRODUCT REVISED**  
As complying with the Florida Building Code  
NOA-No. **24-1007.07**  
Expiration Date: **12/22/2026**  
By: *Manuel Ferrer*  
Miami-Dade Product Control

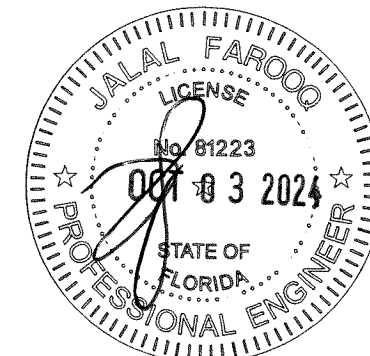

**af c**  
**AL-FAROOQ CORPORATION**  
ENGINEERS & PRODUCT DEVELOPMENT  
9360 SUNSET DRIVE, SUITE 220  
MIAMI, FLORIDA 33173  
TEL. (305) 264-8100 FAX. (305) 262-6978  
COMP-ANL\W16-45ESW

ES-P252 THERMAL ALUM CASEMENT WDW. (S.M.I.)  
**E.S. WINDOWS, LLC**  
3550 N.W. 49 STREET  
MIAMI, FL. 33142  
TEL. (305) 638-5151 FAX. (305) 638-5158

no	date	description	by
C	02.07.18	UPDATED TO 2017 FBC	
D	05.09.19	ALT. VENT ADDED	
E	08.03.20	GENERAL REVISION	
F	06.29.23	UPDATED TO 2023 FBC	
G	10.02.24	WINLITE INTERLAYER ADDED	

date: 06-01-16  
scale: 1/2"=1'-0"  
dr. by: TARIQ  
chk. by:

drawing no. **W16-45**  
sheet 1 of 8

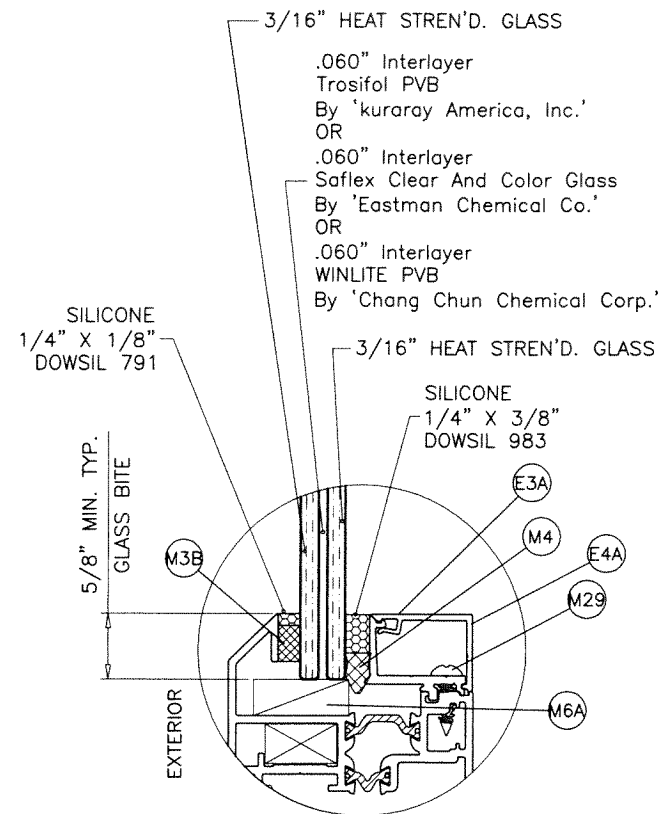

**GLASS TYPE 'A'**  
7/16" OVERALL NOM. THK.

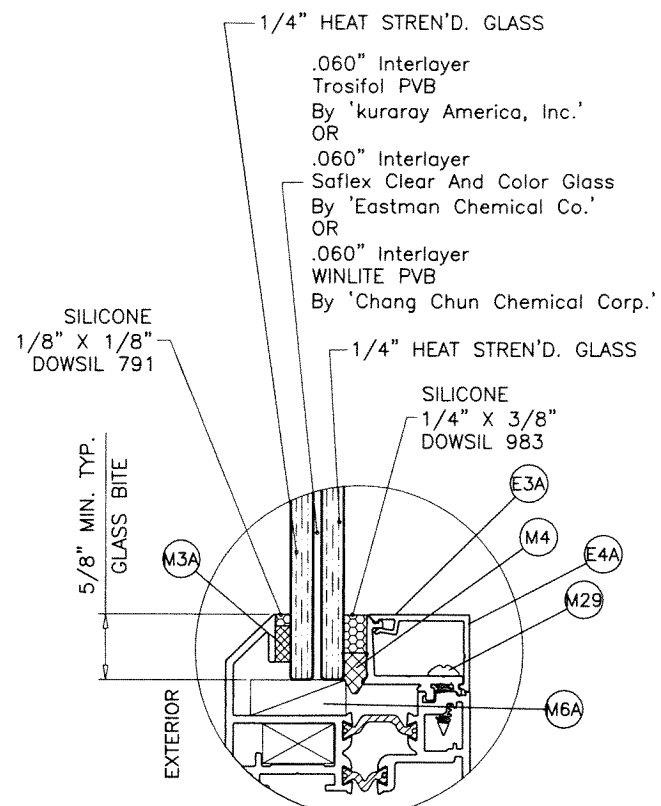

**GLASS TYPE 'A1'**  
9/16" OVERALL NOM. THK.

**GLASS TYPES 'A' & 'A1'**  
MAXIMUM DESIGN LOAD RATING = + 95.0 PSF  
(FOR SIZE SHOWN ON SHEET 1 OR SMALLER) - 105.0 PSF

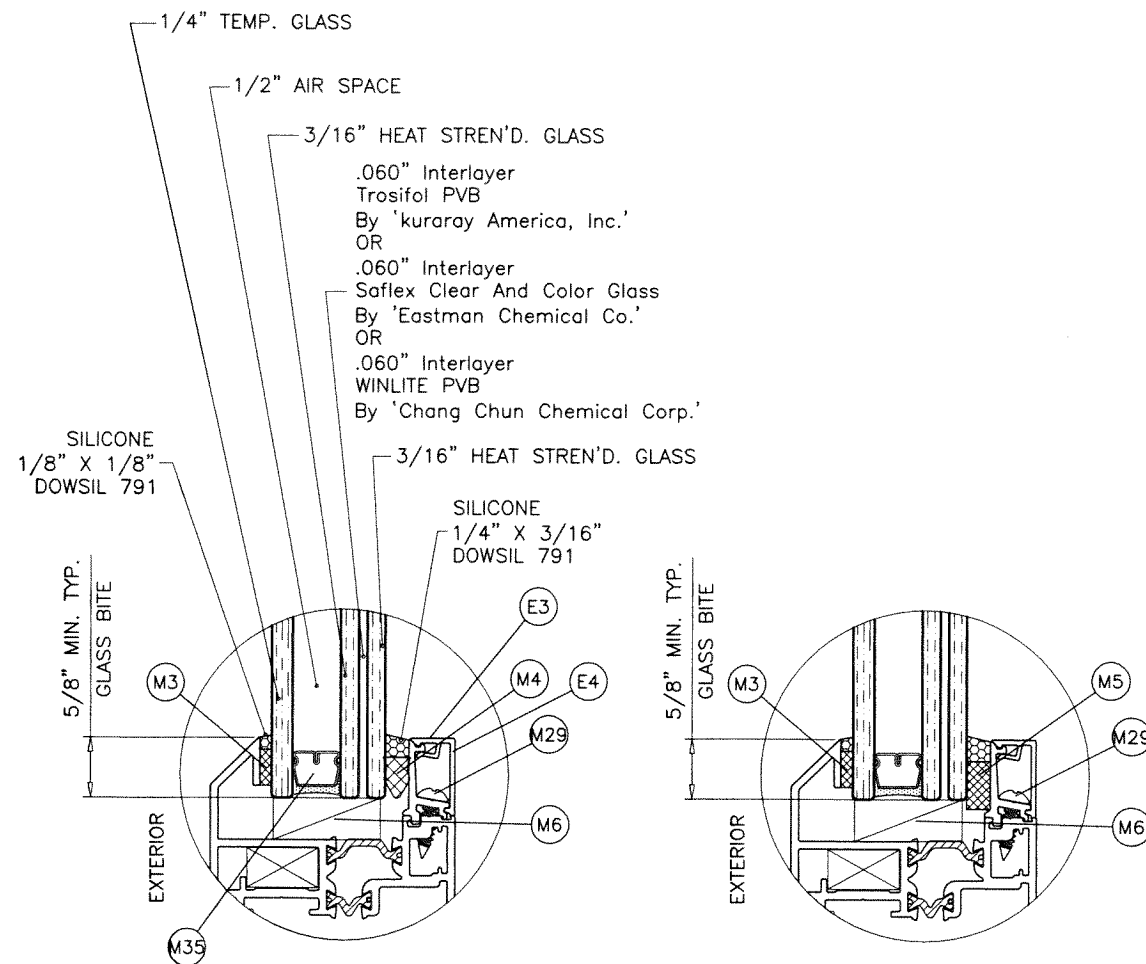

**GLASS TYPE 'B'**  
1-3/16" OVERALL NOM. THK.

**GLASS TYPE 'B'**  
MAXIMUM DESIGN LOAD RATING = + 95.0 PSF  
(FOR SIZE SHOWN ON SHEET 1 OR SMALLER) - 105.0 PSF

**1/2" AIR SPACE CONSISTING OF:**  
**SPACER:**  
'HELIMA' LOW PROFILE ALUMINUM SPACER  
BY 'LINGERMANN GMBH'  
AROUND THE PERIMETER OF THE GLASS.  
**PERIMETER SEALANT:**  
SILICONE  
DOWSIL 791  
GE 2000

NOTE:  
GLASS CAPACITIES ON THIS SHEET ARE  
BASED ON ASTM E1300-09 (3 SEC. GUSTS)  
AND FLORIDA BUILDING COMMISSION  
DECLARATORY STATEMENT DCA05-DEC-219

**PRODUCT REVISED**  
As complying with the Florida  
Building Code  
NOA-No. **24-1007.07**  
Expiration Date: **12/22/2026**  
By: *Manuel Torres*  
Miami-Dade Product Control

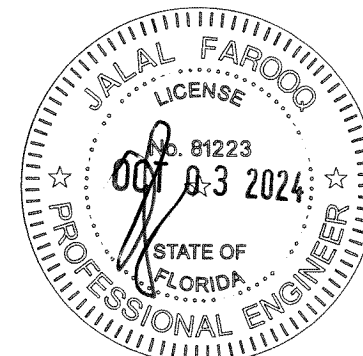

**AL-FAROOQ CORPORATION**  
ENGINEERS & PRODUCT DEVELOPMENT  
9360 SUNSET DRIVE, SUITE 220  
MIAMI, FLORIDA 33173  
TEL. (305) 264-8100 FAX. (305) 262-6978  
C.A.N. 3538

ES-P252 THERMAL ALUM CASEMENT WDW. (S.M.I.)  
**E.S. WINDOWS, LLC**  
3550 N.W. 49 STREET  
MIAMI, FL. 33142  
TEL. (305) 638-5151 FAX. (305) 638-5158

no	date	description
E	08.03.20	GENERAL REVISION
F	06.29.23	NO CHANGE THIS SHEET
G	10.02.24	WINLITE INTERLAYER ADDED

date: 06-01-16  
scale: 1/2" = 1"  
dr. by: TARIQ  
chk. by:  
drawing no.  
**W16-45**  
sheet 1.1 of 8

COMP-ANL\W16-45ESW



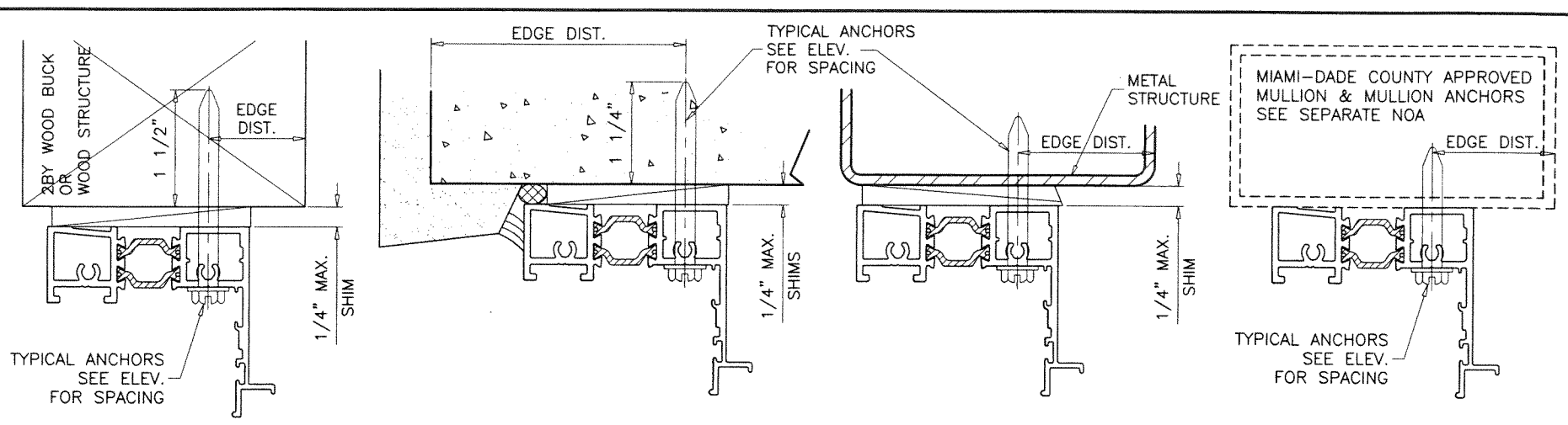
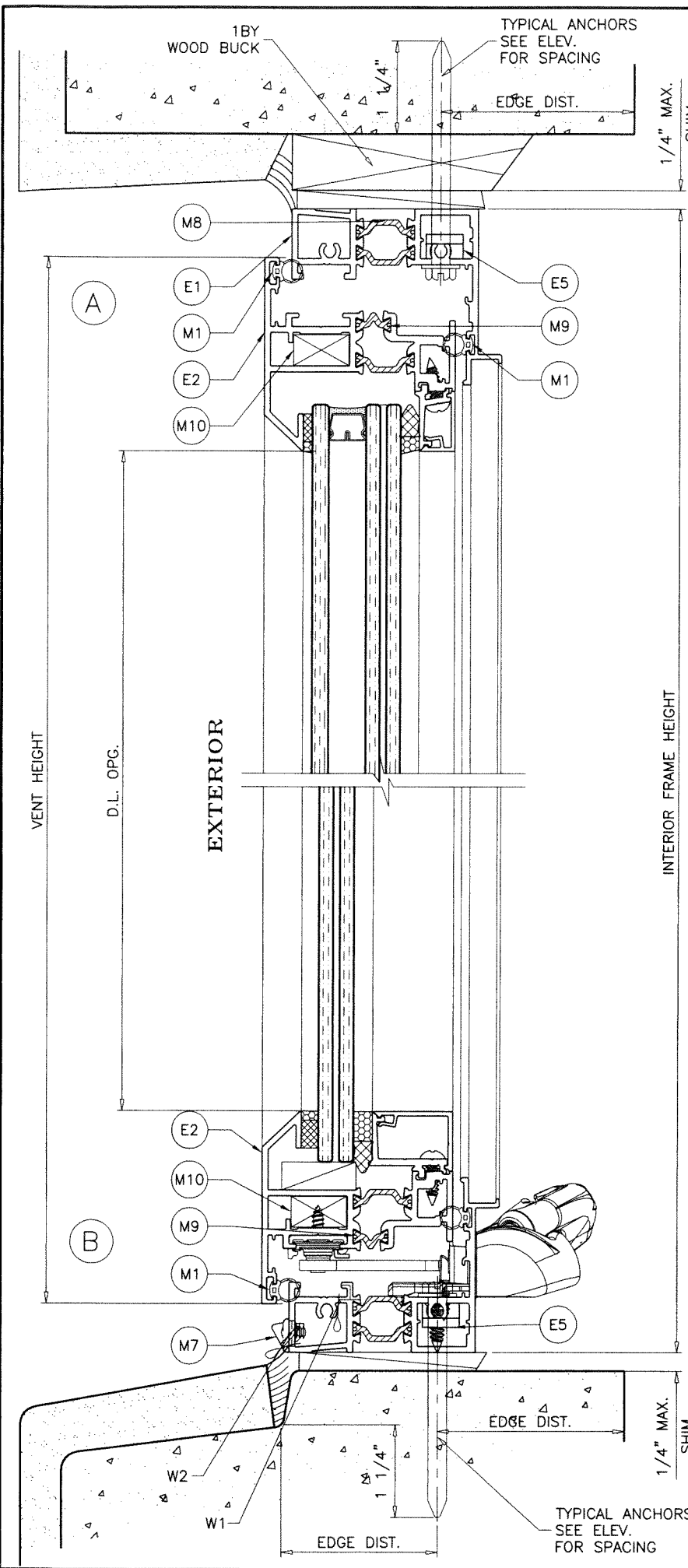

1BY OR 2BY WOOD BUCKS AND METAL STRUCTURE NOT BY 'E.S. WDW.' MUST SUSTAIN LOADS IMPOSED BY GLAZING SYSTEM AND TRANSFER THEM TO THE BUILDING STRUCTURE.

**WEEPHOLES:**

- W1 = 2" X 5/16" WEEPHOLES AT 3-1/4" FROM EACH END AND AT MIDSPAN
- W2 = 1-1/2" X 1/4" WEEPHOLES AT 6" FROM EACH END WITH NYLON BAFFLE

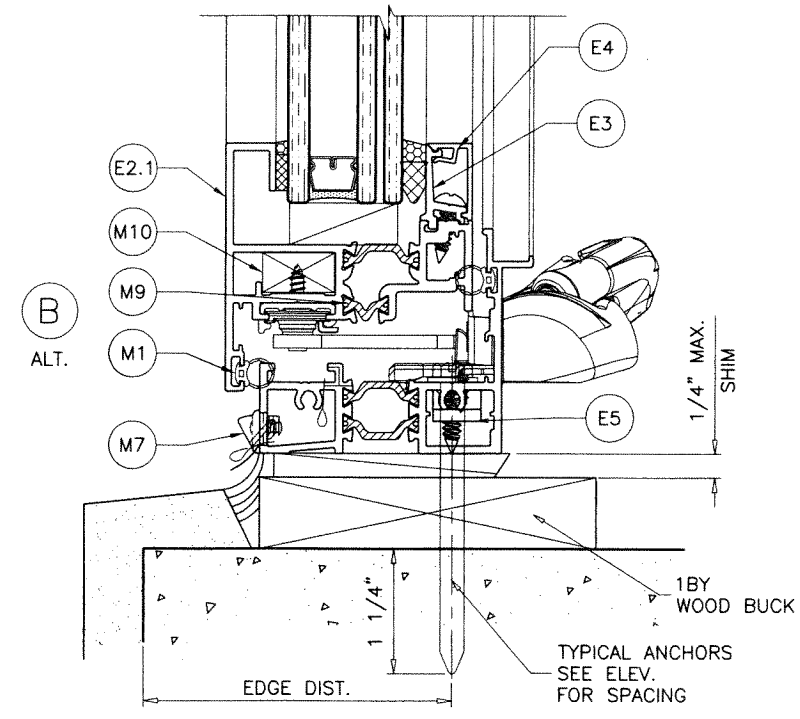

**TYPICAL ANCHORS:** SEE ELEV. FOR SPACING

- 1/4" DIA. CRETE-FLEX SS4 BY 'DEWALT' (Fu=190 KSI, Fy=127 KSI)
- 1/4" DIA. ULTRACON SS4 410 BY 'DEWALT' (Fu=190 KSI, Fy=164 KSI)
- 1/4" DIA. AGGRE-GATOR 300 BY 'DEWALT' (Fu=96 KSI, Fy=57 KSI)
- 1/4" DIA. ULTRACON+ BY 'DEWALT' (Fu=164 KSI, Fy=148 KSI)
- INTO 2BY WOOD BUCKS OR WOOD STRUCTURES
  - 1-1/2" MIN. PENETRATION INTO WOOD (HEAD/SILL/JAMBS)
  - THRU 1BY BUCKS INTO CONC. OR BLOCKS
  - 1-1/4" MIN. EMBED INTO CONCRETE (HEAD/SILL)
  - 1-1/2" MIN. EMBED INTO FILLED BLOCKS (JAMBS)
- DIRECTLY INTO CONC. OR BLOCKS
  - 1-1/4" MIN. EMBED INTO CONCRETE (HEAD/SILL)
  - 1-1/2" MIN. EMBED INTO FILLED BLOCKS (JAMBS)
- 1/4" DIA. BI-FLEX 300 SELF DRILLING SCREWS BY 'DEWALT'
- 1/4" DIA. DRIL-FLEX SELF DRILLING SCREWS BY 'DEWALT' (GRADE 5 CRS)
- INTO MIAMI-DADE COUNTY APPROVED MULLIONS OR
- INTO METAL STRUCTURES (HEAD/SILL/JAMBS)
  - (3) THREADS MIN. TO EXTEND BEYOND METAL THICKNESS
  - ALUMINUM: 1/8" THK. MIN. (6063-T5 MIN.)
  - STEEL: 1/8" THK. MIN. (Fy = 36 KSI MIN.)
  - (STEEL IN CONTACT WITH ALUMINUM TO BE PLATED OR PAINTED)
- ANCHOR EDGE DISTANCES**
  - INTO CONCRETE AND BLOCKS = 2-1/2" MIN.
  - INTO WOOD STRUCTURE = 1" MIN.
  - INTO METAL STRUCTURE = 3/4" MIN.
- WOOD AT HEAD, SILL OR JAMBS SG = 0.55 MIN.
- CONCRETE AT HEAD, SILL OR JAMBS f'c = 3000 PSI MIN.
- C-90 GROUT FILLED BLOCK AT JAMBS f'm = 2000 PSI MIN.

**PRODUCT REVISED**  
 As complying with the Florida Building Code  
 NOA-No. **24-1007.07**  
 Expiration Date: **12/22/2026**  
 By: *Manuel Fern*  
 Miami-Dade Product Control

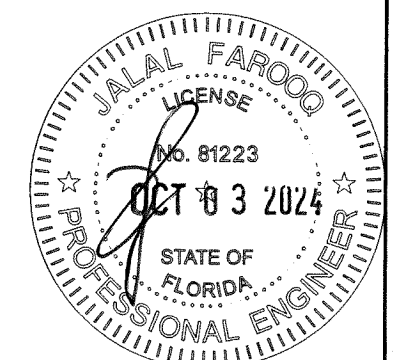

**AL-FAROOQ CORPORATION**  
 ENGINEERS & PRODUCT DEVELOPMENT  
 9360 SUNSET DRIVE, SUITE 220  
 MIAMI, FLORIDA 33173  
 TEL. (305) 264-8100 FAX. (305) 262-6978  
 COMP - ANL \ W16 - 45ESW

---

ES-P252 THERMAL ALUM CASEMENT WDW. (S.M.I.)

**E.S. WINDOWS, LLC**  
 3550 N.W. 49 STREET  
 MIAMI, FL. 33142  
 TEL. (305) 638-5151 FAX. (305) 638-5158

no	date	by	description
C	02.07.18		UPDATED TO 2017 FBC
D	05.09.19		ALT. VENT ADDED
E	08.03.20		GENERAL REVISION
F	06.29.23		NO CHANGE THIS SHEET
G	10.02.24		NO CHANGE THIS SHEET

---

date: 06-01-16  
 scale: 1/2" = 1"  
 dr. by: TARIQ  
 chk. by:

drawing no.  
**W16-45**  
 sheet 2 of 8

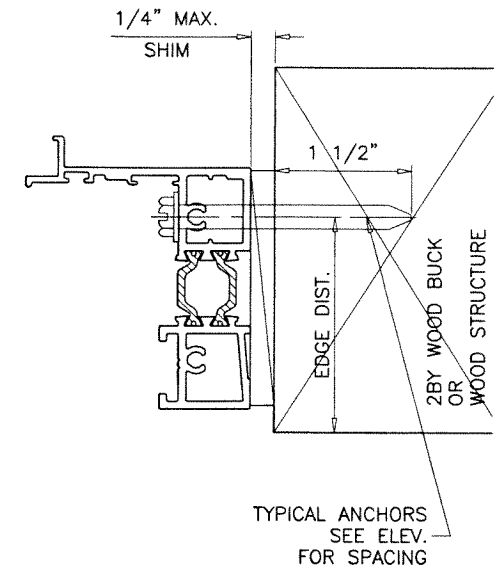
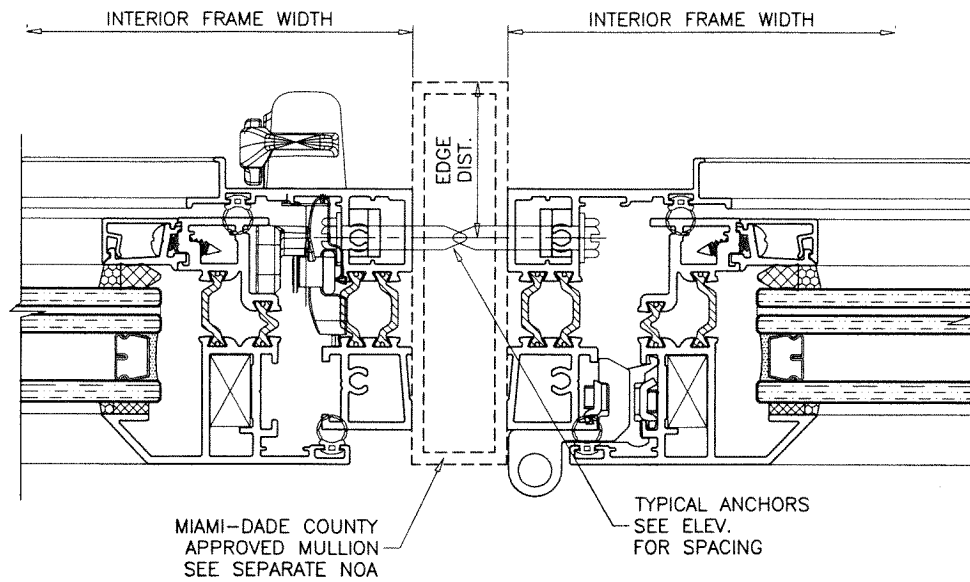
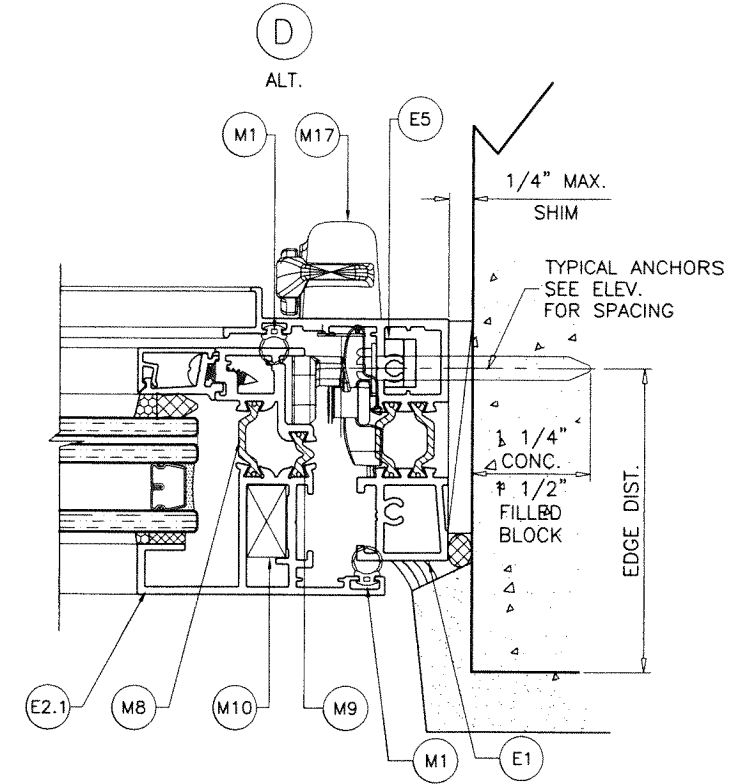
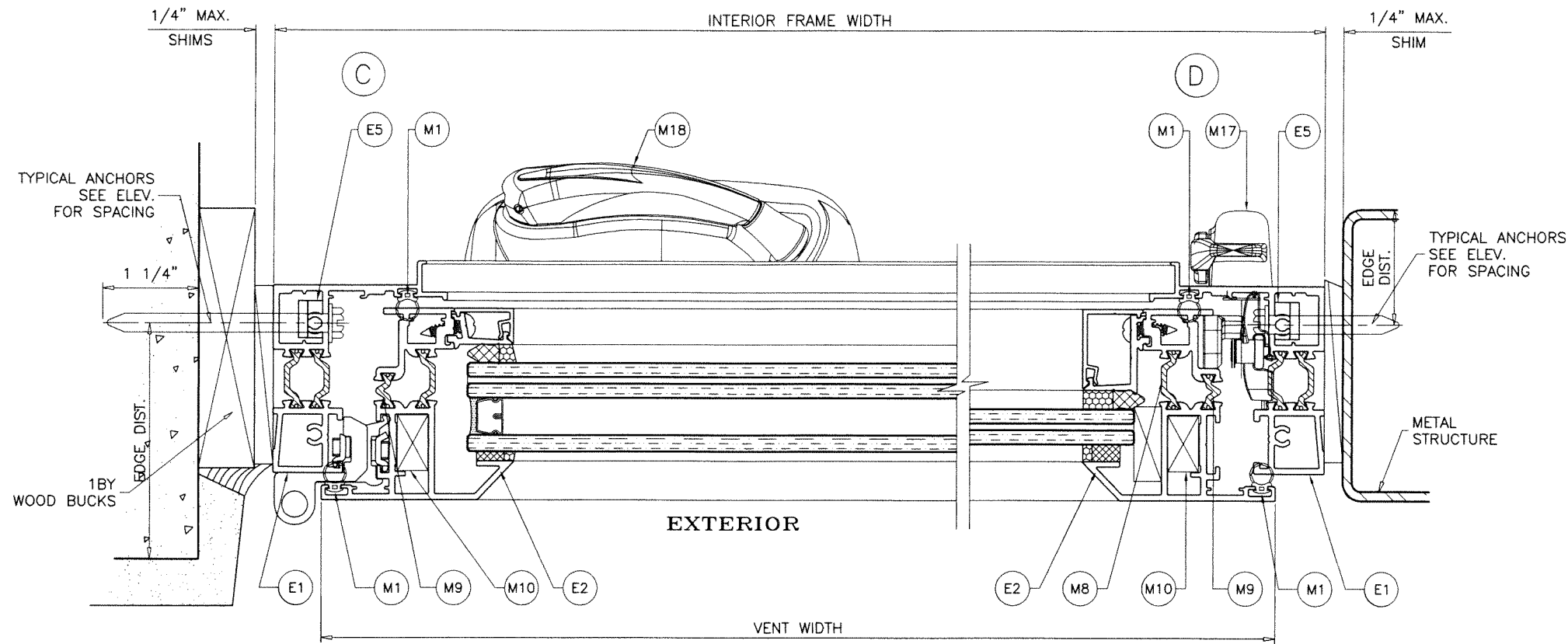

**PRODUCT REVISED**  
 As complying with the Florida Building Code  
 NOA-No. **24-1007.07**  
 Expiration Date: **12/22/2026**  
 By: *Manuel Ferrer*  
 Miami-Dade Product Control

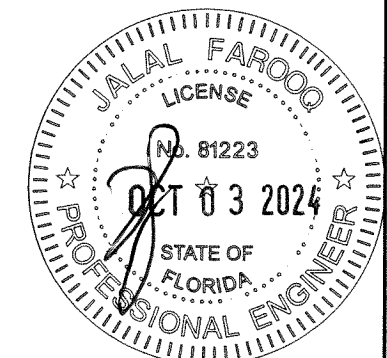

**af c**  
**AL-FAROOQ CORPORATION**  
 ENGINEERS & PRODUCT DEVELOPMENT  
 9360 SUNSET DRIVE, SUITE 220  
 MIAMI, FLORIDA 33173 (C.A.N. 3538)  
 TEL. (305) 264-8100 FAX. (305) 262-6978  
 COMP-ANL \ W16-45ESW

ES-P252 THERMAL ALUM CASEMENT WDW. (S.M.I.)  
**E.S. WINDOWS, LLC**  
 3550 N.W. 49 STREET  
 MIAMI, FL. 33142  
 TEL. (305) 638-5151 FAX. (305) 638-5158

no	date	description	by
C	02.07.18	NO CHANGE THIS SHEET	
D	05.09.19	ALT. VENT ADDED	
E	08.03.20	GENERAL REVISION	
F	06.29.23	NO CHANGE THIS SHEET	
G	10.02.24	NO CHANGE THIS SHEET	

date: 06-01-16  
 scale: 1/2" = 1"  
 dr. by: TARIQ  
 chk. by:  
 drawing no. **W16-45**  
 sheet 3 of 8

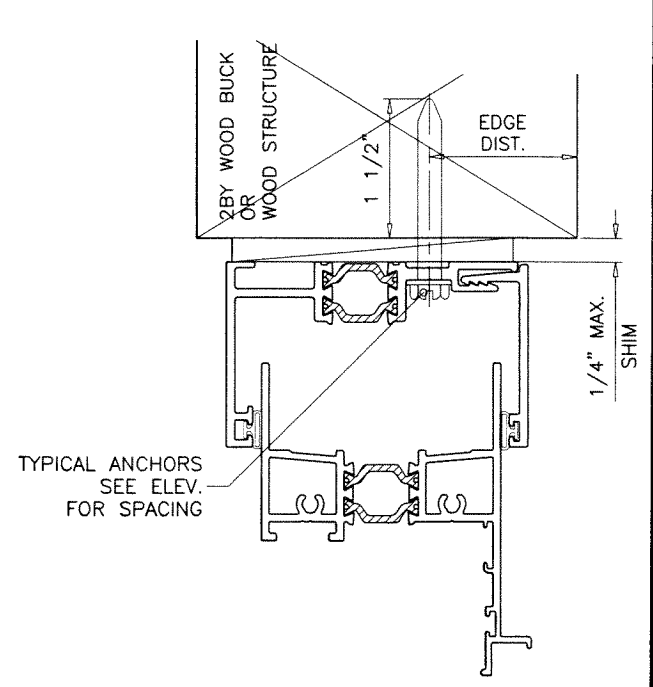
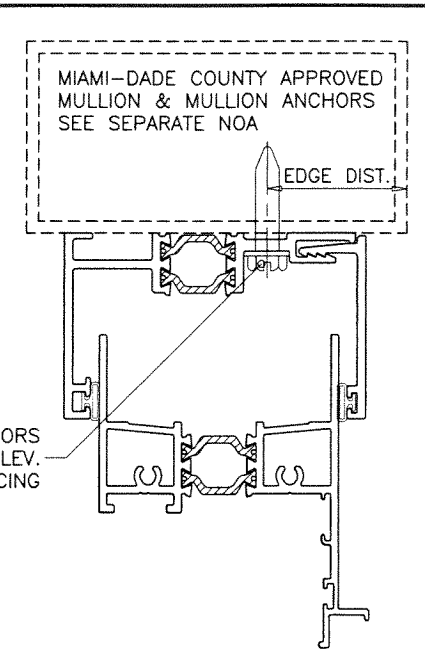
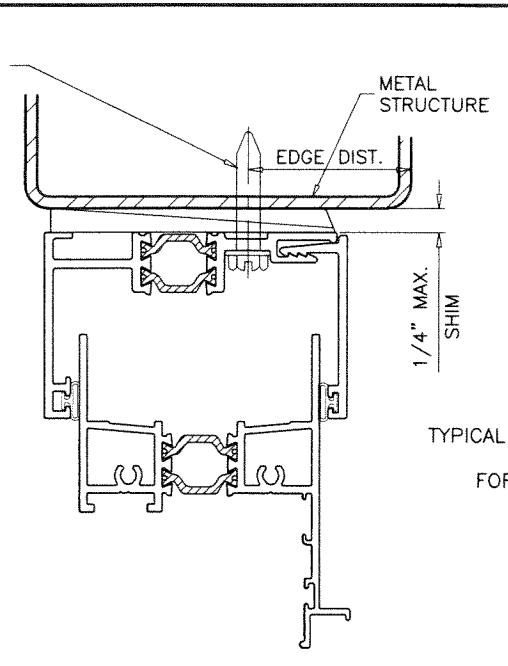
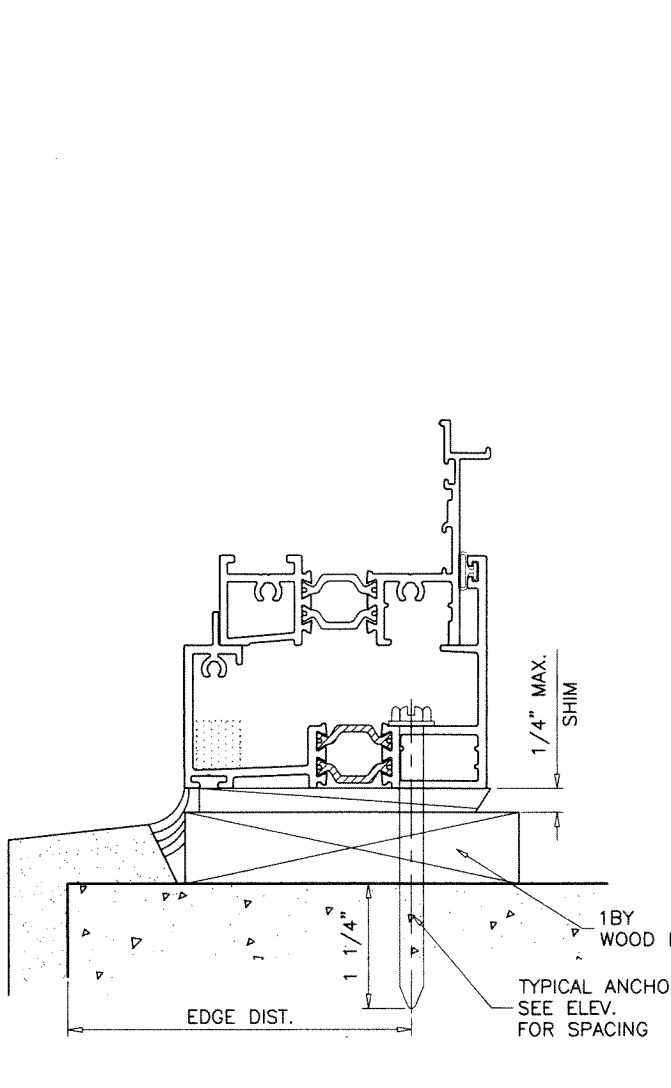
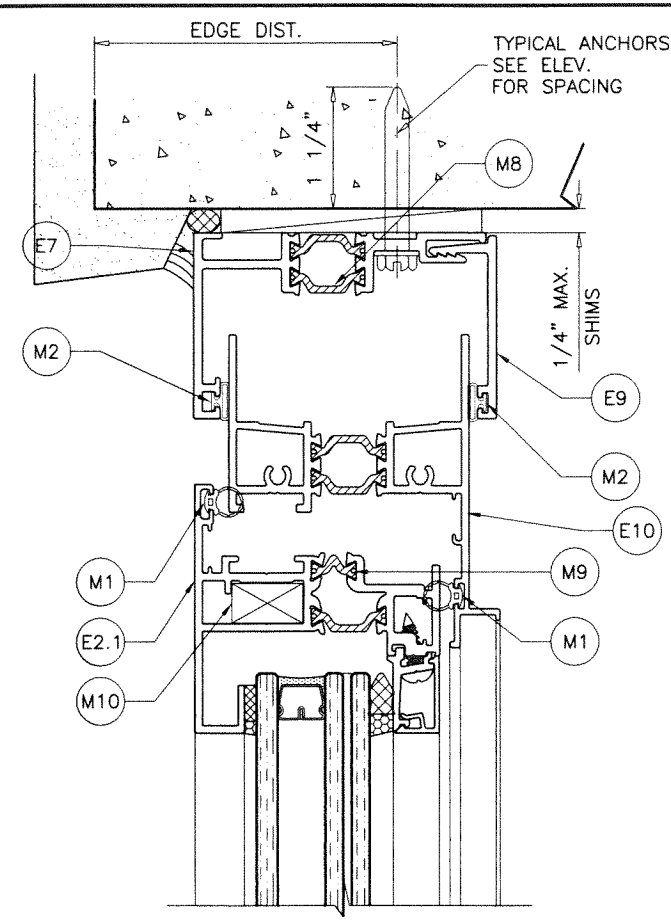
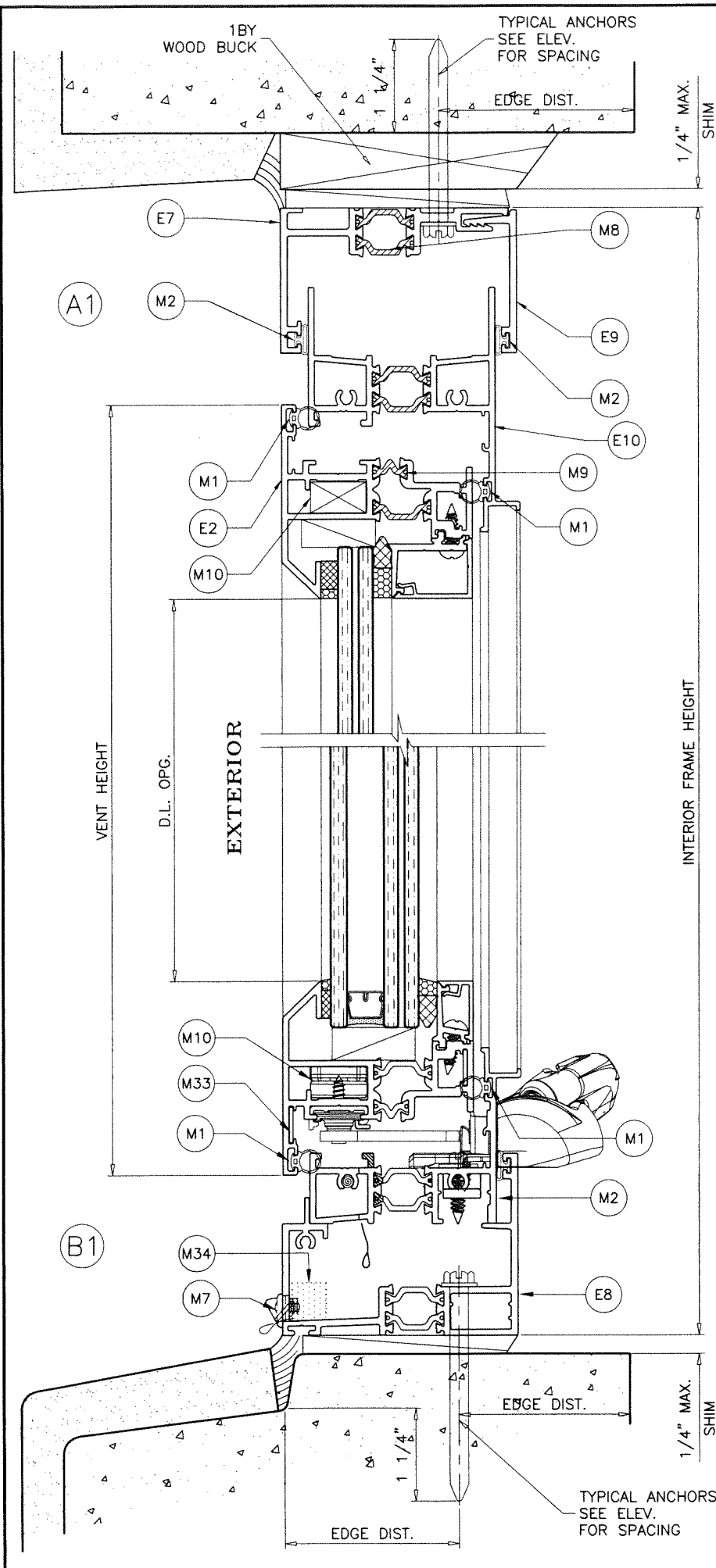

**PRODUCT REVISED**  
 As complying with the Florida Building Code  
 NOA-No. **24-1007.07**  
 Expiration Date: **12/22/2026**  
 By: *Manuel Ferrer*  
 Miami-Dade Product Control

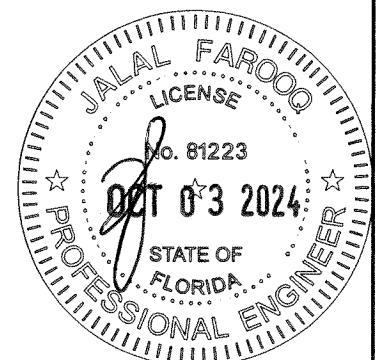

**AL-FAROOQ CORPORATION**  
 ENGINEERS & PRODUCT DEVELOPMENT  
 9360 SUNSET DRIVE, SUITE 220  
 MIAMI, FLORIDA 33173  
 TEL. (305) 262-8100 FAX. (305) 262-6978  
 COMP-ANL \ W16-45ESW

ES-P252 THERMAL ALUM CASEMENT WDW. (S.M.I.)  
**E.S. WINDOWS, LLC**  
 3550 N.W. 49 STREET  
 MIAMI, FL. 33142  
 TEL. (305) 638-5151 FAX. (305) 638-5158

no	date	description	by
C	02.07.18	NO CHANGE THIS SHEET	
D	05.09.19	ALT. VENT ADDED	
E	08.03.20	GENERAL REVISION	
F	06.29.23	NO CHANGE THIS SHEET	
G	10.02.24	NO CHANGE THIS SHEET	

date: 06-01-16  
 scale: 1/2" = 1"  
 dr. by: TARIQ  
 chk. by:

drawing no.  
**W16-45**  
 sheet 4 of 8

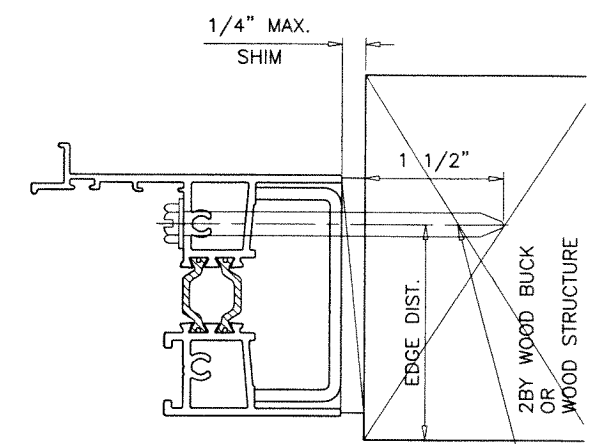
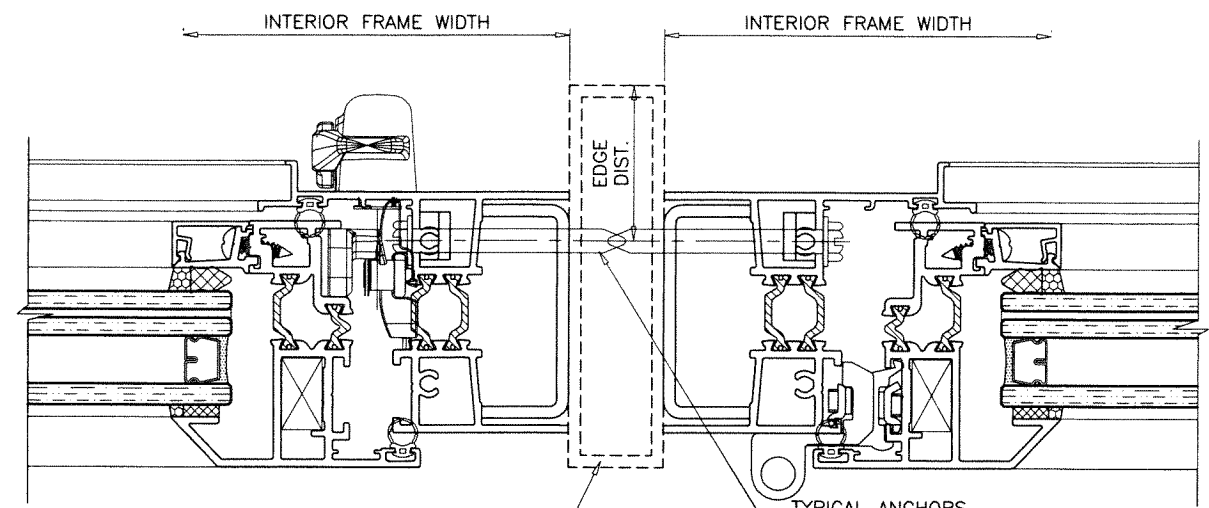
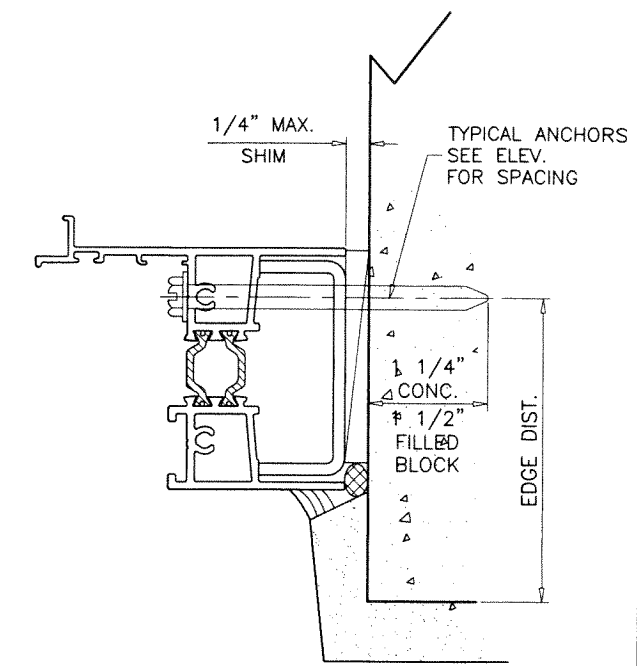
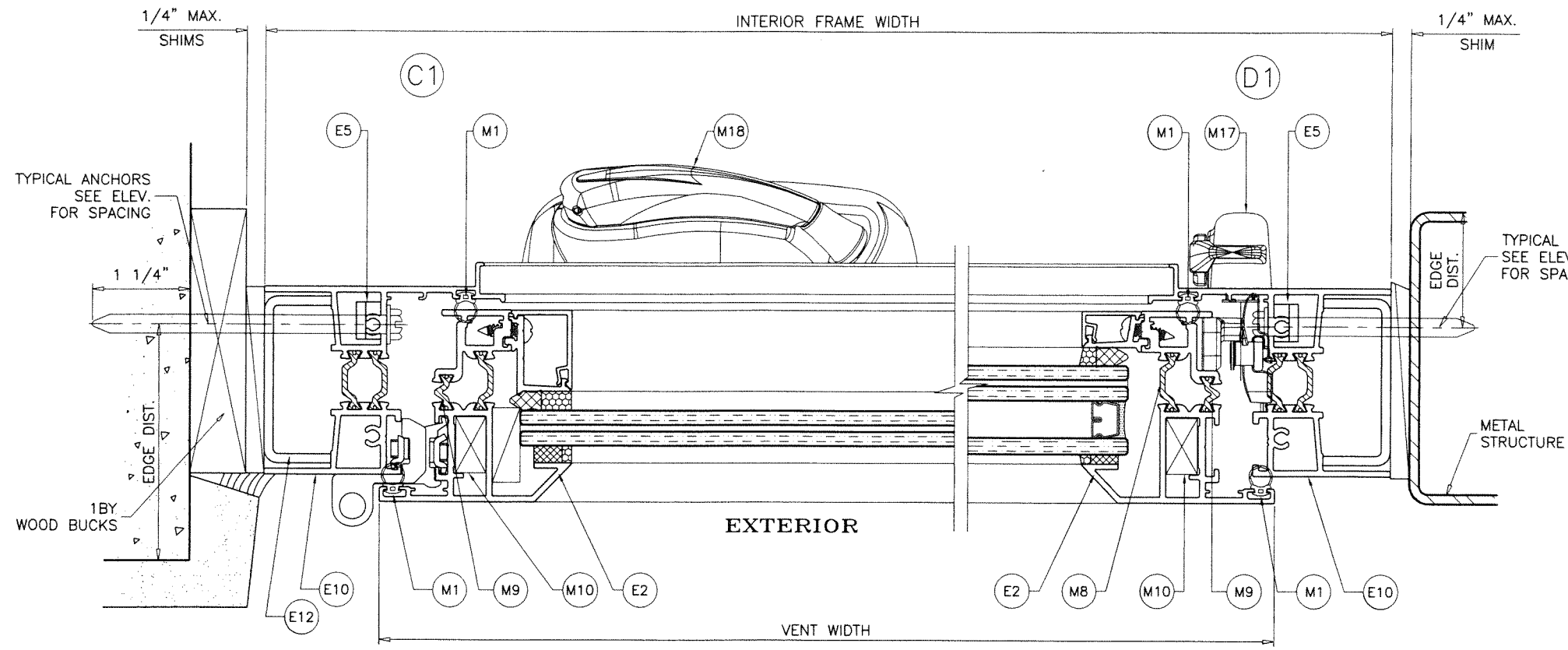

MIAMI-DADE COUNTY  
APPROVED MULLION  
SEE SEPARATE NOA

TYPICAL ANCHORS  
SEE ELEV.  
FOR SPACING

TYPICAL ANCHORS  
SEE ELEV.  
FOR SPACING

**PRODUCT REVISED**  
As complying with the Florida  
Building Code  
NOA-No. **24-1007.07**  
Expiration Date: **12/22/2026**  
By: *Manuel Ferrer*  
Miami-Dade Product Control

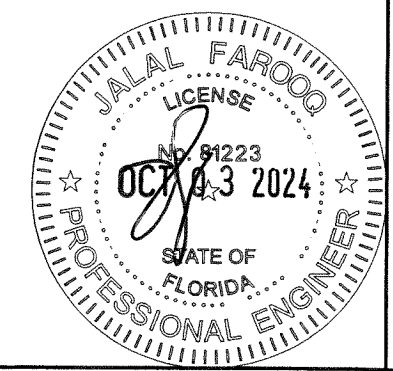

**a f c**  
**AL-FAROOQ CORPORATION**  
ENGINEERS & PRODUCT DEVELOPMENT  
9360 SUNSET DRIVE, SUITE 220  
MIAMI, FLORIDA 33173 (C.A.N. 3538)  
TEL. (305) 264-8100 FAX. (305) 262-6978  
COMP-ANL\W16-45ESW

ES-P252 THERMAL ALUM CASEMENT WDW. (S.M.I.)  
**E.S. WINDOWS, LLC**  
3550 N.W. 49 STREET  
MIAMI, FL. 33142  
TEL. (305) 638-5151 FAX. (305) 638-5158

no	date	description	by
C	02.07.18	NO CHANGE THIS SHEET	
D	05.09.19	NO CHANGE THIS SHEET	
E	08.03.20	GENERAL REVISION	
F	06.29.23	NO CHANGE THIS SHEET	
G	10.02.24	NO CHANGE THIS SHEET	

date: 06-01-16  
scale: 1/2" = 1"  
dr. by: TARIQ  
chk. by:

drawing no.  
**W16-45**  
sheet 5 of 8

ITEM #	PART #	REQD.	DESCRIPTION	MATERIAL	MANF./SUPPLIER/REMARKS
E1	ES-P250-001/P252-001	4	FLUSH FRAME HEAD/SILL/JAMB	6063-T6	-
E2	ES-P252-002/P250-003	4	VENT	6063-T6	-
E2.1	ES-P252-026/P250-003	4	ALT. VENT	6063-T6	-
E3	ES-P252-004	4/	VENT GLASS STOP (INSUL. LAM. GLASS)	6063-T6	-
E3A	ES-P252-029	4/	VENT GLASS STOP (LAM. GLASS)	6063-T6	-
E4	ES-P252-003	-	COVER IMPACT (INSUL. LAM. GLASS)	6063-T6	-
E4A	ES-P252-030	-	COVER IMPACT (LAM. GLASS)	6063-T6	-
E5	AAC-A-027	1/	CORNER FRAME ATTACHMENT ANGLE	6063-T6	-
E7	ES-P250-010/P251-013	AS REQD.	RECEPTOR HEAD	6063-T6	-
E8	ES-P251-016/032	1	RECEPTOR SILL	6063-T6	-
E9	ES-P251-014	1	RECEPTOR STOP	6063-T6	-
E10	ES-P250-017/P252-012	-	EQUAL LEG FRAME HEAD/JAMB	6063-T6	-
E12	-	AS REQD.	JAMB REINF. CHANNEL	6063-T6	-
M1	ES-P251-G05	AS REQD.	INTERIOR VENT GASKET	EPDM	TREMCO #TX-20003E, DUROMETER 70±5 SHORE A
M2	27-245	AS REQD.	FRAME RECEPTOR	EPDM	CANALVIDRIOS, DUROMETER 65±5 SHORE A
M3	-	-	GLAZING TAPE (1/8" X 3/8")	POLYURETHANE	-
M3A	-	AS REQD.	GLAZING TAPE (3/16" X 3/8")	POLYURETHANE	-
M3B	-	AS REQD.	GLAZING TAPE (1/4" X 3/8")	POLYURETHANE	-
M4	ES-H340-G02	-	GLAZING WEDGE	EPDM	DUROMETER 60±5 SHORE A
M5	80-378	-	GLAZING WEDGE (1/2" X 1/4")	EPDM	CANALVIDRIOS, DUROMETER 80±5 SHORE A
M6	ES-6025-B01	-	SETTING BLOCK AT VENT	EPDM	TREMCO TR-1870E, DUROMETER 85±5 SHORE A
M6A	NS-25-B03A	-	SETTING BLOCK AT VENT	EPDM	DUROMETER 85±5 SHORE A
M7	WA2L	-	WEEP HOLE COVER	-	PREFERRED
M8	2479	AS REQD.	INSULBAR 20MM OFFSET	POLYAMIDE	ENSINGER
M9	2531	AS REQD.	INSULBAR 12MM OFFSET	POLAMIDE	ENSINGER
M10	0337	-	CORNER JOINT	DIECAST ALUM	MASTER
M11	CL02-002X	-	LOCK POINT BAR	ST. STEEL	INTERLOCK
M12	CL02-2059-00B	-	STRIKER	-	INTERLOCK
M13	CL02-2060-00B	-	LOCKING BAR GUIDE	-	INTERLOCK
M14	C011-0151-085	-	13.5" SA OPERATOR LOW PROFILE RH	ST. STEEL	INTERLOCK
M15	C011-0152	-	13.5" SA OPERATOR LOW PROFILE LH	ST. STEEL	INTERLOCK
M16	C011-0704	-	TRACK	ST. STEEL	INTERLOCK
M17	CL01-0475	-	MULTIPOINT HANDLE	DIE CAST ZINC	INTERLOCK
M18	C011-0605-XXX	-	COVER OPERATOR HANDLE LEFT	-	INTERLOCK
M19	C011-0606-XXX	-	COVER OPERATOR HANDLE RIGHT	-	INTERLOCK
M20	CL01-2250-XXX	-	SNAP ON COVER	DIE CAST ZINC	INTERLOCK
M21	CL01-1050-XXX	-	SNAP ON HANDLE	COPOLYMER	INTERLOCK
M22	C001-4001	-	CLAMP WASHER	ST. STEEL	INTERLOCK
M23	A1199X0003	-	EURO HINGE	ST. STEEL	AMC
M24	#10 X 2" FH	-	FRAME CORNER FASTENER	ST. STEEL	-
M26	#10 X 3/4" PH	-	FRAME CORNER ANGLE FASTENER	ST. STEEL	-
M27	#8 X 1" FH	-	STRIKER FASTENER	ST. STEEL	-
M28	#8 X 1/2" FH	-	GUIDE, OPERATOR, TRACK FASTENER	ST. STEEL	-
M29	#8 X 5/8" PH SMS	-	GLASS STOP FASTENER	ST. STEEL	AT 4" FROM ENDS & 8-1/4" O.C.
M30	#8-32 X 1/2" PH	-	LOCKING HANDLE CLAMP WASHER FASTENER	ST. STEEL	-
M31	#8 X 1/2" PH	-	END DAM FASTENER	ST. STEEL	-
M32	C001-4000	-	CLAMP WASHER	ROH	INTERLOCK
M33	PJS43-SS	-	CORNER LOCK	ST. STEEL	-
M34	WPSA-N1	-	3/4" X 3/4" X 2" RETICALATED FOAM	OPEN CELL FOAM	30 PP1
M35	HELIMA	-	LOW PROFILE SPACER	ALUMINUM	LINGERMANN GMBH & CO. KG

**SEALANTS:**

FRAME AND VENT CORNERS AND INSTALLATION SCREWS AT SILL SEALED WITH WHITE/ALUMINUM COLORED GENERAL PURPOSE SILICONE SEALANT BY MACKLANBURG-DUNCAN.

**LOCKS:**

SEVEN POINT LOCK SYSTEM BY 'INTERLOCK' LOCATED AT FRAME JAMB AT 10" FROM BOTTOM FASTENED WITH (2) #8-32 X 1/2" PH MS

(10) SLIDE BAR NYLON GUIDES, EACH FASTENED TO FRAME JAMB WITH (2) #8 X 1" FH SMS

SURFACE MOUNT NYLON KEEPERS AT VENT FACING LOCKING POINTS EACH FASTENED WITH (2) #10 X 3/4" FH SDS

**HINGES:**

SURFACE MOUNT METALLIC PIVOT HINGE LOCATED AT FRAME JAMB AT 8" FROM TOP & BOTTOM FASTENED WITH (2) #12-28 X 1/2" FH MS (2) 1/4-20 X 1/4" SET SCREW

**OPERATOR:**

ROTO OPERATOR BY 'INTERLOCK' LOCATED AT SILL END FASTENED WITH (6) #8 X 3/4" FH SMS (2) #8-32 X 7/16" FH MS

**PRODUCT REVISED**  
 As complying with the Florida Building Code  
 NOA-No. **24-1007.07**  
 Expiration Date: **12/22/2026**  
 By: *Manuel Perez*  
 Miami-Dade Product Control

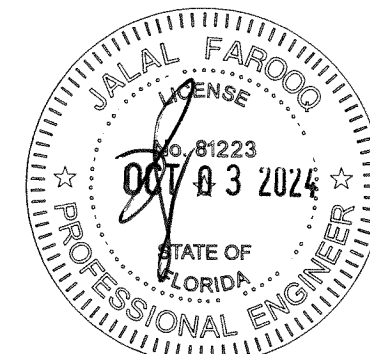

**af c**  
**AL-FAROOQ CORPORATION**  
 ENGINEERS & PRODUCT DEVELOPMENT  
 9360 SUNSET DRIVE, SUITE 220  
 MIAMI, FLORIDA 33173 (C.A.N. 3538)  
 TEL. (305) 264-8100 FAX. (305) 262-6978  
 COMP-ANL\W16-45ESW

ES-P252 THERMAL ALUM CASEMENT WDW. (S.M.I.)  
**E.S. WINDOWS, LLC**  
 3550 N.W. 49 STREET  
 MIAMI, FL. 33142  
 TEL. (305) 638-5151 FAX. (305) 638-5158

revisions:	no	date	description
	C	02.07.18	NO CHANGE THIS SHEET
	D	05.09.19	ALT. VENT ADDED
	E	08.05.20	GENERAL REVISION
	F	06.29.23	NO CHANGE THIS SHEET
	G	10.02.24	NO CHANGE THIS SHEET

date: 06-01-16  
 scale: 1/2" = 1"  
 dr. by: TARIQ  
 chk. by:  
 drawing no. **W16-45**  
 sheet 6 of 8

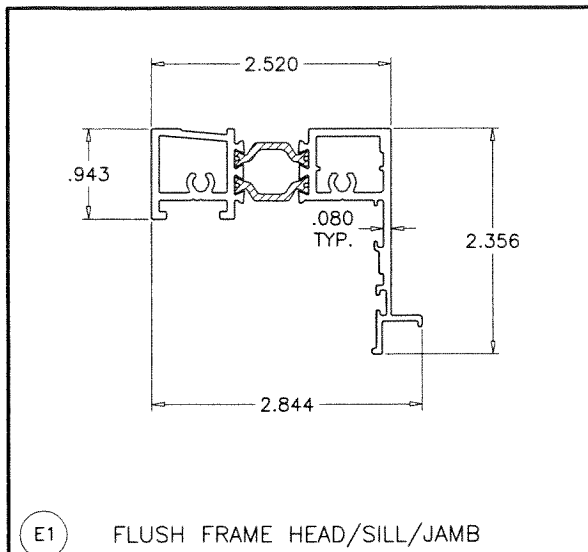

E1 FLUSH FRAME HEAD/SILL/JAMB

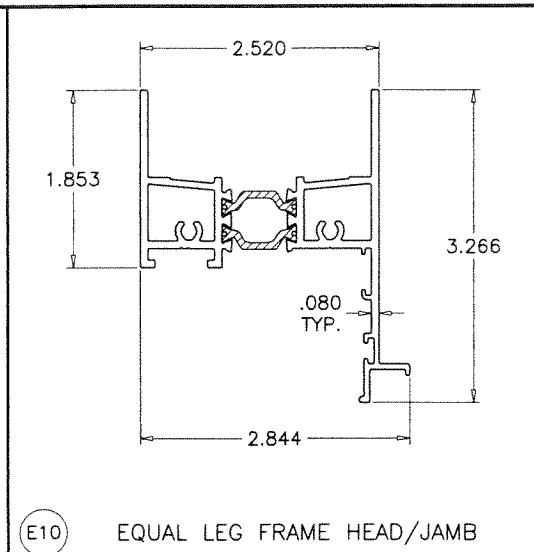

E10 EQUAL LEG FRAME HEAD/JAMB

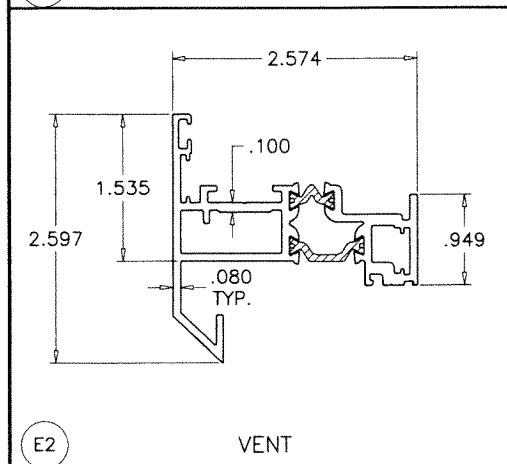

E2 VENT

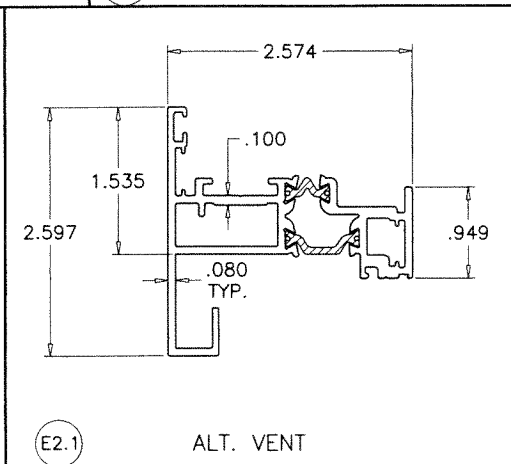

E2.1 ALT. VENT

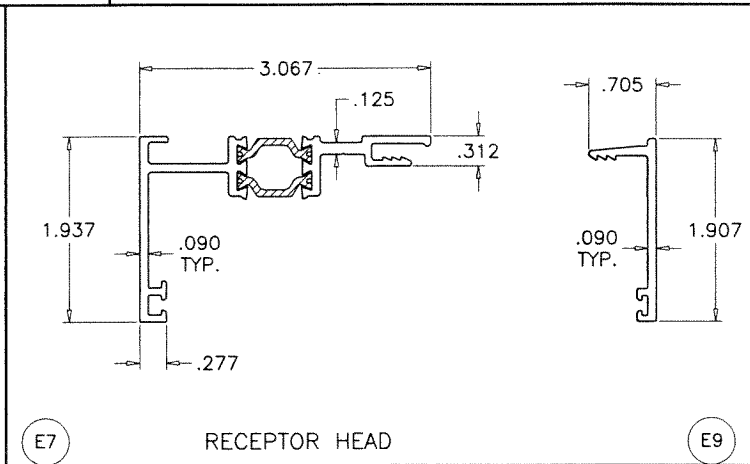

E7 RECEPTOR HEAD



E9 RECEPTOR SILL

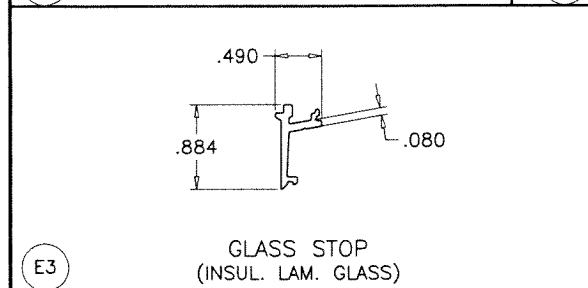

E3 GLASS STOP (INSUL. LAM. GLASS)

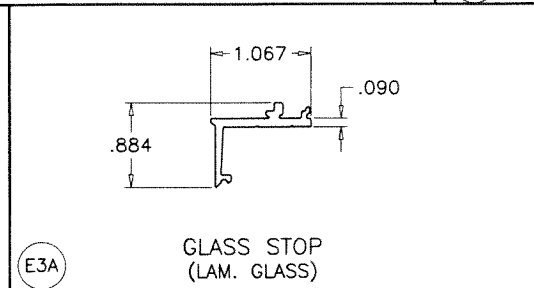

E3A GLASS STOP (LAM. GLASS)

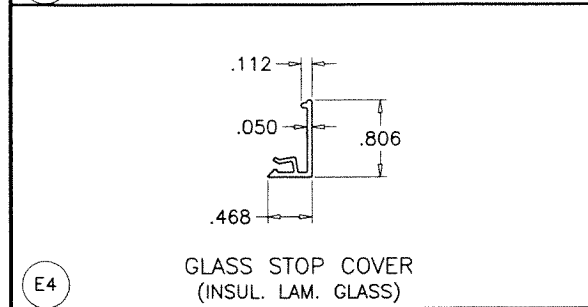

E4 GLASS STOP COVER (INSUL. LAM. GLASS)

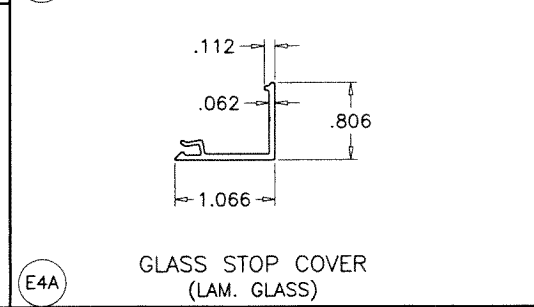

E4A GLASS STOP COVER (LAM. GLASS)

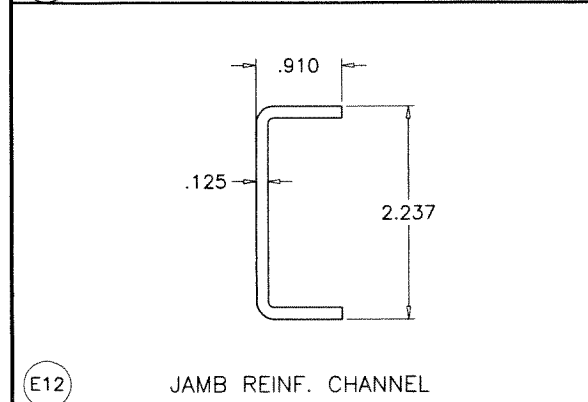

E12 JAMB REINF. CHANNEL

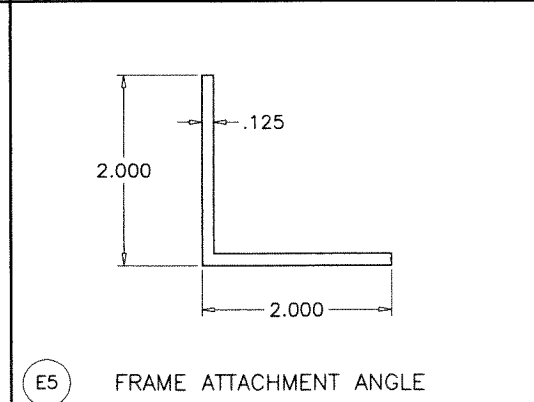

E5 FRAME ATTACHMENT ANGLE

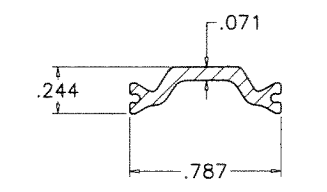

M8 20MM OFFSET

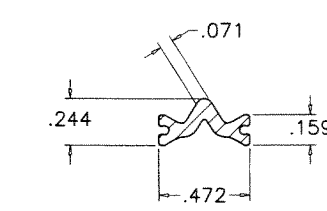

M9 12MM OFFSET

TECATHERM® 66 GF INSULBARS  
SCALE 1:1  
MATERIAL = POLYAMIDE  
TENSILE STRENGTH = 13031 PSI  
RATE OF BURN = .752 IN./MIN.  
SELF IGNITION TEMP. = 793° F  
FLASH IGNITION TEMP. = 781°C  
SMOKE DENSITY = 1.63

**PRODUCT REVISED**  
As complying with the Florida Building Code  
NOA-No. **24-1007.07**  
Expiration Date: **12/22/2026**  
By: *Manuel Fern*  
Miami-Dade Product Control

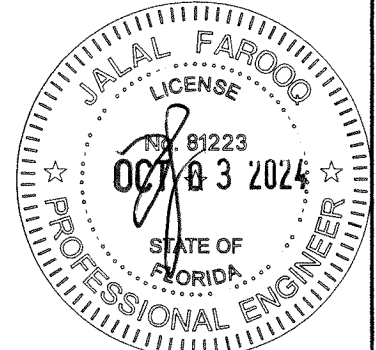

**AL-FAROOQ CORPORATION**  
ENGINEERS & PRODUCT DEVELOPMENT  
9360 SUNSET DRIVE, SUITE 220  
MIAMI, FLORIDA 33173 (C.A.N. 3538)  
TEL. (305) 264-8100 FAX. (305) 262-6978  
COMP-ANL\W16-45ESW

ES-P252 THERMAL ALUM CASEMENT WDW. (S.M.I.)  
**E.S. WINDOWS, LLC**  
3550 N.W. 49 STREET  
MIAMI, FL. 33142  
TEL. (305) 638-5151 FAX. (305) 638-5158

no	date	description
C	02.07.18	NO CHANGE THIS SHEET
D	05.09.19	ALT. VENT ADDED
E	08.03.20	GENERAL REVISION
F	06.29.23	NO CHANGE THIS SHEET
G	10.02.24	NO CHANGE THIS SHEET

date: 06-01-16  
scale: 1/2" = 1"  
dr. by: TARIQ  
chk. by:

drawing no.  
**W16-45**  
sheet 7 of 8

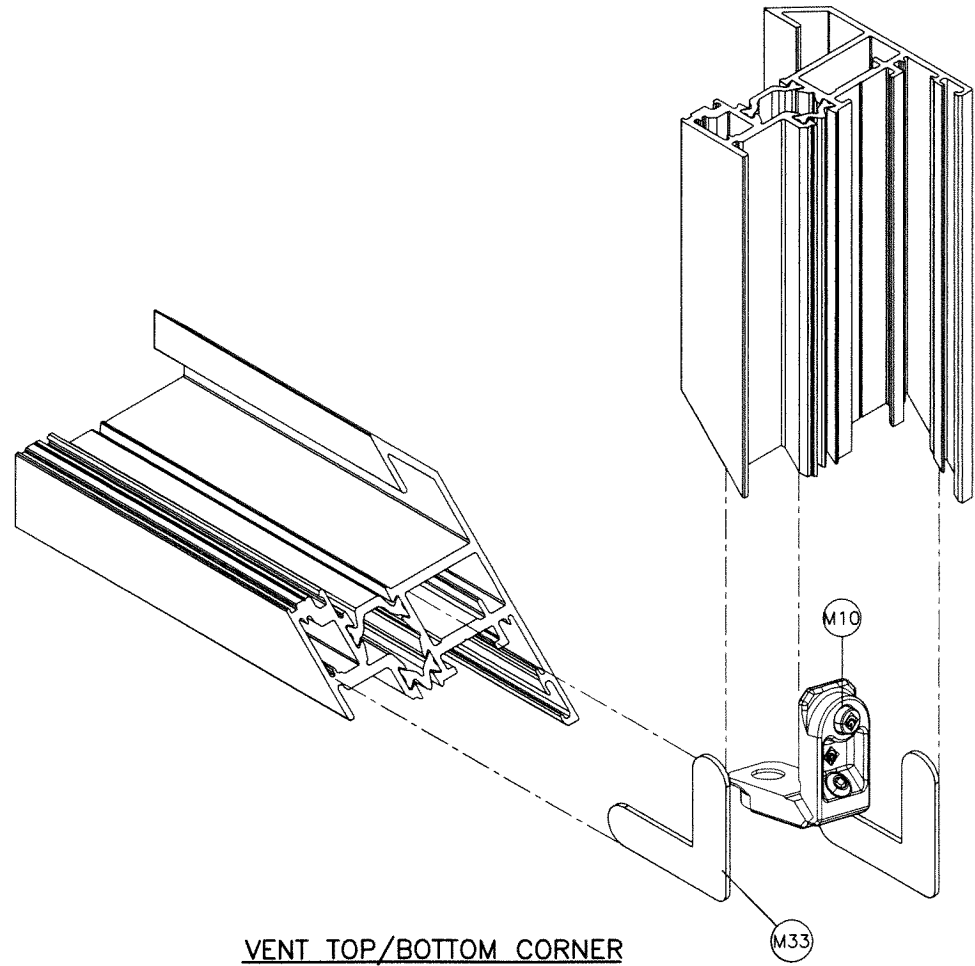

VENT TOP/BOTTOM CORNER

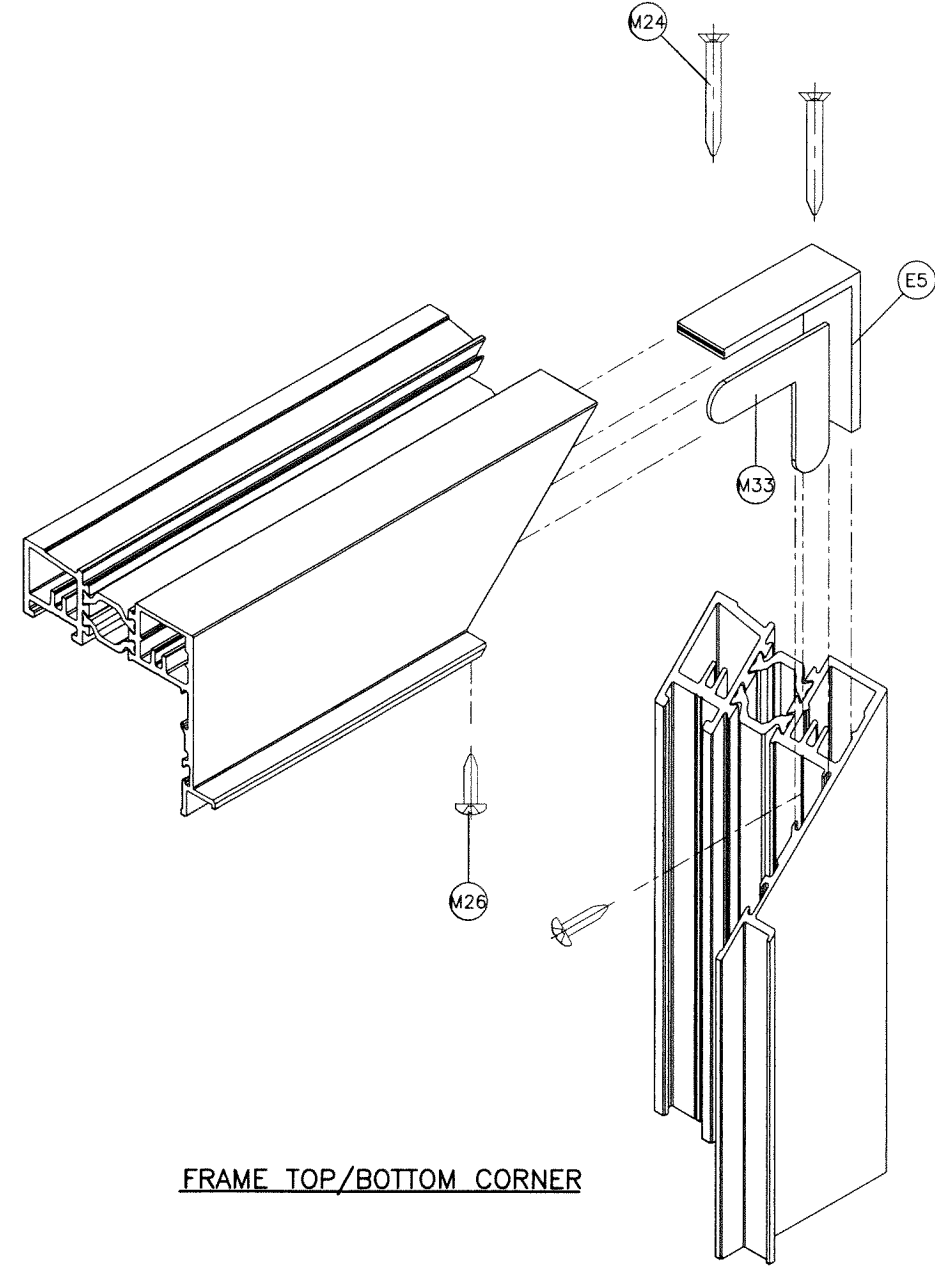

FRAME TOP/BOTTOM CORNER

**PRODUCT REVISED**  
 As complying with the Florida Building Code  
 NOA-No. **24-1007.07**  
 Expiration Date: **12/22/2026**  
 By: *Manuel Ferns*  
 Miami-Dade Product Control

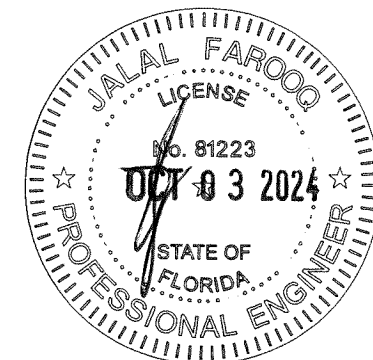

**af c**  
**AL-FAROOQ CORPORATION**  
 ENGINEERS & PRODUCT DEVELOPMENT  
 9360 SUNSET DRIVE, SUITE 220 (C.A.N. 3538)  
 MIAMI, FLORIDA 33173  
 TEL. (305) 264-8100 FAX. (305) 262-6978  
 COMP-ANL \ W16-45ESW

ES-P252 THERMAL ALUM CASEMENT WDW. (S.M.I.)  
**E.S. WINDOWS, LLC**  
 3550 N.W. 49 STREET  
 MIAMI, FL. 33142  
 TEL. (305) 638-5151 FAX. (305) 638-5158

no	date	by	description
C	02.07.18		NO CHANGE THIS SHEET
D	05.09.19		NO CHANGE THIS SHEET
E	08.03.20		GENERAL REVISION
F	06.29.23		NO CHANGE THIS SHEET
G	10.02.24		NO CHANGE THIS SHEET

date: 06-01-16  
 scale: 1/2" = 1"  
 dr. by: TARIQ  
 chk. by:

drawing no.  
**W16-45**  
 sheet **8** of **8**