



MIAMI-DADE COUNTY
PRODUCT CONTROL SECTION

11805 SW 26 Street, Room 208
Miami, Florida 33175-2474
T (786) 315-2590 F (786) 315-2599

DEPARTMENT OF REGULATORY AND ECONOMIC RESOURCES (RER)
BOARD AND CODE ADMINISTRATION DIVISION

www.miamidade.gov/building

NOTICE OF ACCEPTANCE (NOA)

USG Corporation
550 West Adams Street
Chicago, IL 60661

SCOPE: This NOA is being issued under the applicable rules and regulations governing the use of construction materials. The documentation submitted has been reviewed and accepted by Miami-Dade County RER-Product Control Section to be used in Miami Dade County and other areas where allowed by the Authority Having Jurisdiction (AHJ).

This NOA shall not be valid after the expiration date stated below. The Miami-Dade County Product Control Section (In Miami Dade County) and/or the AHJ (in areas other than Miami Dade County) reserve the right to have this product or material tested for quality assurance purposes. If this product or material fails to perform in the accepted manner, the manufacturer will incur the expense of such testing and the AHJ may immediately revoke, modify, or suspend the use of such product or material within their jurisdiction. RER reserves the right to revoke this acceptance if it is determined by Miami-Dade County Product Control Section that this product or material fails to meet the requirements of the applicable building code.

This product is approved as described herein and has been designed to comply with the Florida Building Code, including the High Velocity Hurricane Zone.

DESCRIPTION: USG Paraline Plus Aluminum Exterior Ceiling System

APPROVAL DOCUMENT: Drawing No. **PAR-01** through **PAR-06**, titled “Paraline Plus Exterior Ceiling System”, sheets 1 through 6 of 6, dated 04/22/16, prepared by manufacturer, signed and sealed by Carl D. Fussner, P.E., bearing the Miami-Dade County Product Control Revision stamp with the Notice of Acceptance number and expiration date by the Miami-Dade County Product Control Section.

MISSILE IMPACT RATING: None

LABELING: Each piece shall be permanently marked at not more than 4’ o.c. with a number or marking and the packaging shall include the manufacturer's name or logo, city, state, model number or name, Miami-Dade County NOA number, test standards and net free area per FBC 1709.10.2 and 1709.10.3.

RENEWAL of this NOA shall be considered after a renewal application has been filed and there has been no change in the applicable building code negatively affecting the performance of this product.

TERMINATION of this NOA will occur after the expiration date or if there has been a revision or change in the materials, use, and/or manufacture of the product or process. Misuse of this NOA as an endorsement of any product, for sales, advertising or any other purposes shall automatically terminate this NOA. Failure to comply with any section of this NOA shall be cause for termination and removal of NOA.

ADVERTISEMENT: The NOA number preceded by the words Miami-Dade County, Florida, and followed by the expiration date may be displayed in advertising literature. If any portion of the NOA is displayed, then it shall be done in its entirety.

INSPECTION: A copy of this entire NOA shall be provided to the user by the manufacturer or its distributors and shall be available for inspection at the job site at the request of the Building Official. This NOA revises **NOA No. 21-0923.03** and consists of this page 1 and evidence pages E-1 and E-2, as well as approval document mentioned above.

The submitted documentation was reviewed by **Manuel Perez, P.E.**

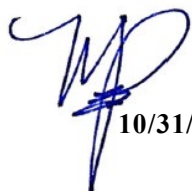

10/31/24

NOA No. 24-1011.09
Expiration Date: October 20, 2026
Approval Date: November 07, 2024
Page 1

USG Corporation

NOTICE OF ACCEPTANCE: EVIDENCE SUBMITTED

1. EVIDENCE SUBMITTED UNDER PREVIOUS NOA's

A. DRAWINGS

1. Manufacturer's die drawings and sections.
(Submitted under NOA No. 15-1223.05)
2. Drawing No. **PAR-01** through **PAR-06**, titled "Paraline Plus Exterior Ceiling System", sheets 1 through 6 of 6, dated 04/22/16, prepared by manufacturer, signed and sealed by Carl D. Fussner, P.E.
(Submitted under NOA No. 15-1223.05)

B. TESTS

1. Test reports on: 1) Uniform Static Air Pressure Test, Loading per FBC TAS 202-94
2) Cyclic Wind Pressure Loading per FBC, TAS 203-94
3) Tensile Test per ASTM E8-08
along with marked-up drawings of a Celebration Suspended Ceiling, prepared by Intertek-Architectural Testing, Inc., Test Report No. **E2131.01-450-18**, dated 06/01/15, with revision 1 dated 07/02/15, signed and sealed by Michael D. Stremmel, P.E.
(Submitted under NOA No. 15-1223.05)

C. CALCULATIONS

1. Anchorage calculations prepared by PEI Engineering Services, Inc., dated 08/23/16, signed and sealed by Carl D. Fussner, P.E.
(Submitted under NOA No. 15-1223.05)

D. QUALITY ASSURANCE

1. Miami-Dade Department of Regulatory and Economic Resources (RER)

E. MATERIAL CERTIFICATIONS

1. None.

F. STATEMENTS

1. Statement letter of conformance, complying with **FBC 7th Edition (2020)**, dated 10/06/21, issued by PEI Engineering Services, Inc., signed and sealed by Carl D. Fussner, P.E.
(Submitted under NOA No. 21-0923.03)
2. Statement letter of no financial interest, dated 05/27/16, issued by PEI Engineering Services, Inc., signed and sealed by Carl D. Fussner, P.E.
(Submitted under NOA No. 15-1223.05)



Manuel Perez, P.E.
Product Control Examiner
NOA No. 24-1011.09
Expiration Date: October 20, 2026
Approval Date: November 07, 2024

USG Corporation

NOTICE OF ACCEPTANCE: EVIDENCE SUBMITTED

1. EVIDENCE SUBMITTED UNDER PREVIOUS NOA's (CONTINUED)

G. OTHERS

1. Notice of Acceptance No. **15-1223.05**, issued to USG Paraline Plus Aluminum Exterior Ceiling System, approved on 10/20/16 and expiring on 10/20/21.

2. NEW EVIDENCE SUBMITTED

A. DRAWINGS

1. None.

B. TESTS

1. None.

C. CALCULATIONS

1. None.

D. QUALITY ASSURANCE

1. Miami-Dade Department of Regulatory and Economic Resources (RER)

E. MATERIAL CERTIFICATIONS

1. None.

F. STATEMENTS

1. Statement letter of conformance, complying with **FBC 8th Edition (2023)**, dated 09/16/24, issued by PEI Engineering Services, Inc., signed and sealed by Carl D. Fussner, P.E.

G. OTHERS

1. Notice of Acceptance No. **21-0923.03**, issued to USG Corporation for USG Paraline Plus Aluminum Exterior Ceiling System, approved on 12/23/21 and expiring on 10/20/26.



Manuel Pérez, P.E.
Product Control Examiner
NOA No. 24-1011.09
Expiration Date: October 20, 2026
Approval Date: November 07, 2024

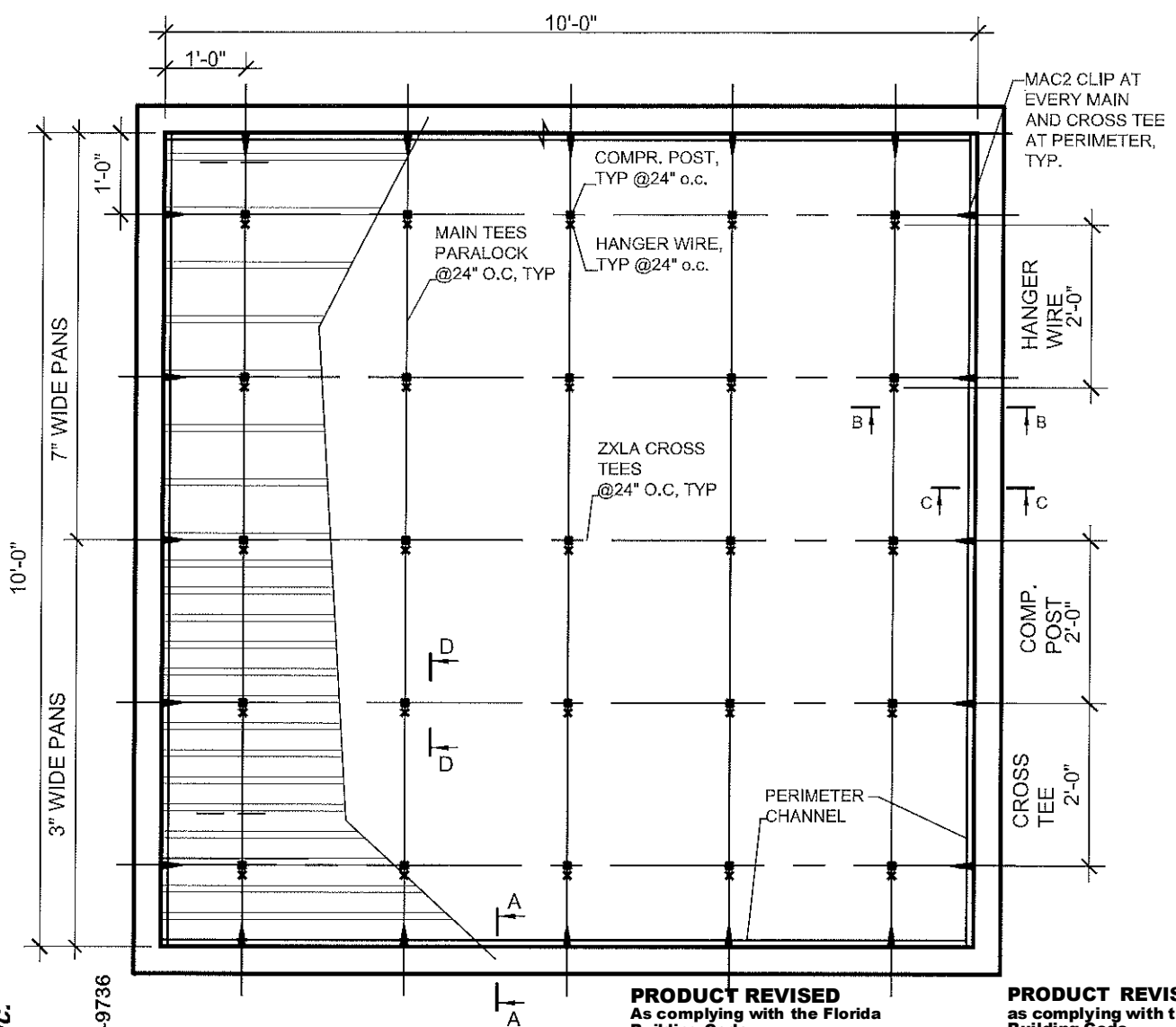

PEI Engineering Services, Inc.
 58640 State Road 15
 Goshen, IN 46528
 Phone: (574) 533-0337 - Fax: (574) 533-9736
 FL C.O.A. Number 27447

PARALINE PLUS
 PARALINE PLUS (PARALOCK) WITH
 ALUMINUM PANS
 MAIN TEES AT 24" O.C.
 CROSS TEES AT 24" O.C.
 COMPRESSION POSTS AT 24" O.C.
 PANS 3" X 10' AND 7" X 10'

PRODUCT REVISED
 As complying with the Florida
 Building Code
 NOA-No. **24-1011.09**
 Expiration Date: **10/20/2026**
 By: *Manuel Ferr*
 Miami-Dade Product Control

PRODUCT REVISED
 as complying with the Florida
 Building Code
 NOA-No. **21-0923.03**
 Expiration Date: **10/20/2026**
 By: *Manuel Ferr*
 Miami-Dade Product Control

PRESSURE:
 +75 PSF UPWARD
 -35 PSF DOWNWARD

Approved as complying with the
 Florida Building Code
 Date 10/20/2016
 NOA# 15-1223.05
 Miami Dade Product Control
 By: *[Signature]*

Carl D. Fussner
 AUG 22 2016

	UNITED STATES GYPSUM CO. 550 West Adams Street Chicago, Illinois 60661 1-800-874-4968	DWG.# PAR-01 DATE: 04/22/2016	PLAN PARALINE PLUS EXTERIOR CEILING SYSTEM MIAMI DADE CO NOA	SHEET 1 OF 6
--	---	----------------------------------	---	-----------------

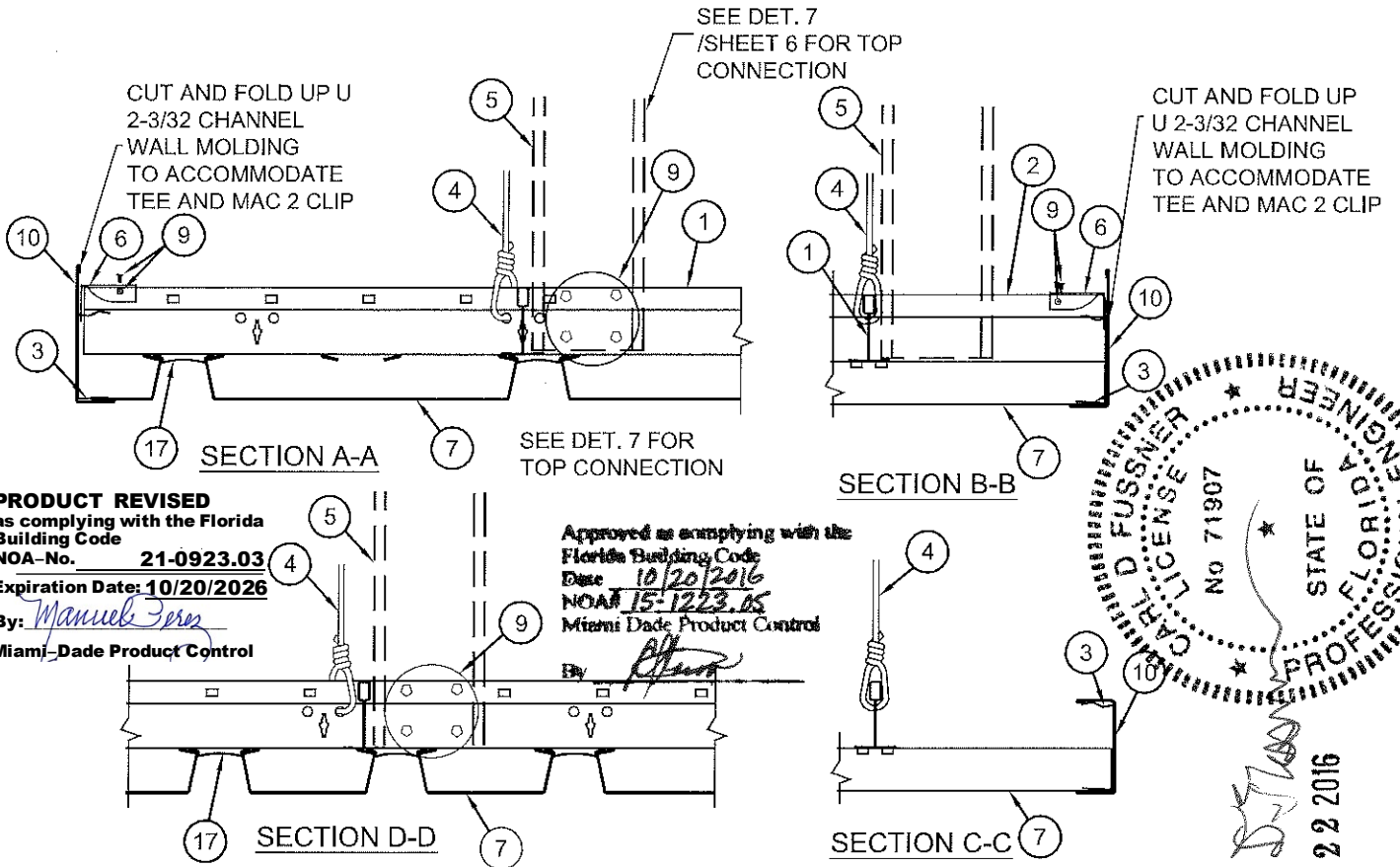

PRODUCT REVISED
 as complying with the Florida
 Building Code
 NOA-No. **21-0923.03**
 Expiration Date: **10/20/2026**
 By: *Manuel Fern*
 Miami-Dade Product Control

Approved as complying with the
 Florida Building Code
 Date **10/20/2016**
 NOA# **15-1223-05**
 Miami Dade Product Control
 By: *[Signature]*

CARL D. FUSSNER
 No. 71907
 STATE OF FLORIDA
 PROFESSIONAL ENGINEER
Carl D. Fussner
AUG 22 2016

1	PARALOCK MAIN TEE, Fy (MIN) 40 KSI
2	ZXLA 224 CROSS TEE, Fy (MIN) 40 KSI
3	U-2-3/32 HOLD-DOWN CLIP; 2" LONG AT 3" PANS, 6" AT 7" PANS, 10-1/2" @12" O.C. AT LONGIT. SIDES.
4	12 GA HANGER WIRE
5	2 1/2" - 22 GA. STUD COMPRESSION POST
6	MAC 2 CLIP ATTACHED WITH 2 SCREWS, SEE SECTION A-A, SHEET 2 OF 6.
7	3" OR 7" WIDE PAN
8	1/4" LAG SCREW w/ 1 1/4" EMBEDMENT
9	#8 x 7/16" PAN HEAD SCREW
10	U 2-3/32 CHANNEL WALL MOLDING
11	HILTI 3/8" KWIK BOLT TZ-CS EXPANSION ANCHOR (OR EQUIVALENT)
12	L 1-1/2 x 1-1/2 x 6 IN. LONG 12GA. CLIP
14	1/4" HILTI HHDCA CEILING HANGER WITH 1-1/4" EMBEDMENT.
15	0.145" DIA. HILTI X-U 15 (OR EQUIVALENT)
16	HILTI X-CW X-U-27 FASTENER, 1-1/4" EMBEDMENT
17	SNAP-LOC INSERT
18	#8 1-1/4" SCREW SHARP POINT
19	#8 - 1 1/8" DRILL POINT SCREW
20	3/16" CARBON STEEL OR STAINLESS STEEL TAPCON ANCHOR.

PRODUCT REVISED
 As complying with the Florida
 Building Code
 NOA-No. **24-1011.09**
 Expiration Date: **10/20/2026**
 By: *Manuel Fern*
 Miami-Dade Product Control

PEI Engineering Services, Inc.
 58640 State Road 15
 Goshen, IN 46528
 Phone: (574) 533-0337 - Fax: (574) 533-9736
 FL C.O.A. Number 27447

USG
UNITED STATES GYPSUM CO.
 550 West Adams Street
 Chicago, Illinois 60661
 1-800-874-4968

DWG.# **PAR-02**
 DATE: **04/22/2016**

SECTIONS
 PARALINE PLUS
 EXTERIOR CEILING
 MIAMI DADE CO NOA

SHEET
 2 OF 6

ANCHORING NOTES:
WALL MOLDING TO STRUCTURE

USE DETAILS 1 THROUGH 3 FOR ATTACHMENT.

WOOD SUBSTRATE DETAIL 1
 USE #8 SCREW OR EQUIVALENT WITH 2" MINIMUM
 PENETRATION AT 16" O.C.

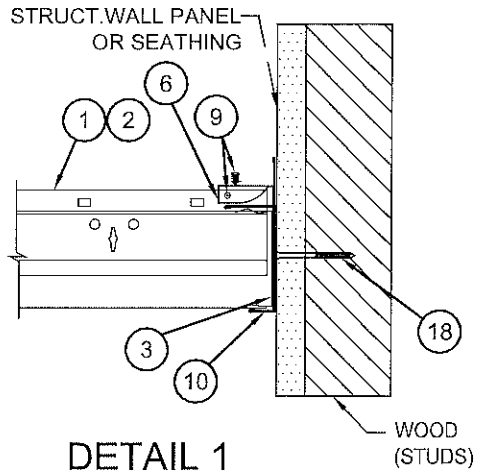

DETAIL 1

Approved as complying with the
 Florida Building Code
 Date: 10/20/2016
 NOA# 15-1223.05
 Miami Dade Product Control

By: [Signature]

PRODUCT REVISED
 as complying with the Florida
 Building Code
 NOA-No. 21-0923.03
 Expiration Date: 10/20/2026
 By: Manuel Fern
 Miami-Dade Product Control

STEEL SUBSTRATE, DETAIL 2
 MOLDING CHANNEL: USE #8 1-1/4" MIN.
 SCREW OR EQUIVALENT AT 16" O.C.

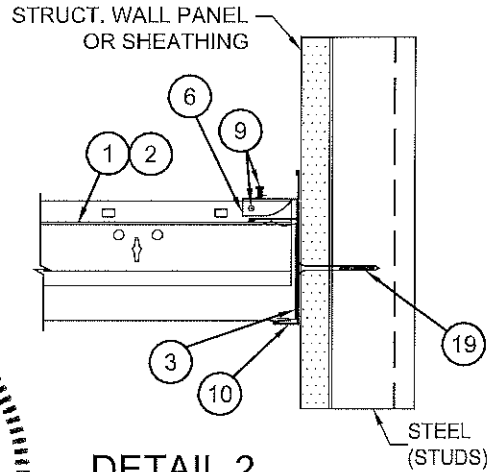

DETAIL 2

PRODUCT REVISED
 As complying with the Florida
 Building Code
 NOA-No. 24-1011.09
 Expiration Date: 10/20/2026
 By: Manuel Fern
 Miami-Dade Product Control

[Signature]
 AUG 22 2016

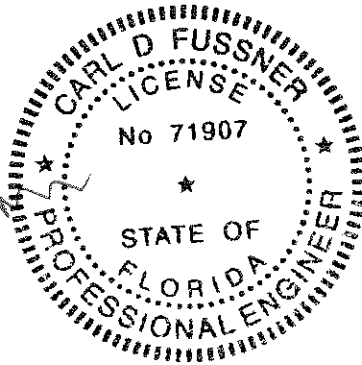

CONCRETE SUBSTRATE, DETAIL 3
 MOLDING CHANNEL: USE 3/16" DIA. TAPCON ANCHOR
 OR EQUIVALENT WITH 1" MINIMUM EMBEDMENT AND 2"
 MIN. EDGE DISTANCE IN 3000 PSI CONCRETE OR
 MEDIUM-WEIGHT CMU BLOCKS AT 16" O.C.

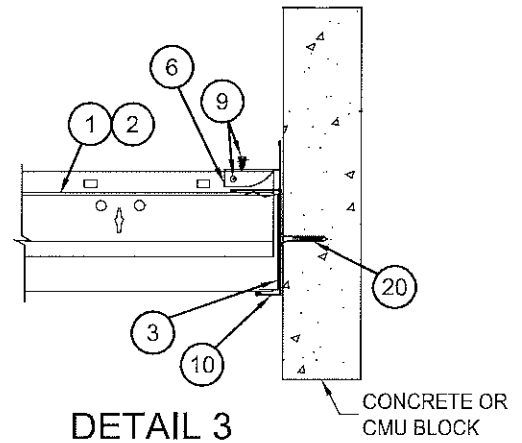

DETAIL 3

PEI Engineering Services, Inc.

58640 State Road 15
 Goshen, IN 46528
 Phone: (574) 533-0337 - Fax: (574) 533-9736
 FL C.O.A. Number 27447

USG
 UNITED STATES
 GYPSUM CO.
 550 West Adams Street
 Chicago, Illinois 60661
 1-800-874-4968

DWG.# PAR-03
 DATE: 04/22/2016

WALL DETAILS
 PARALINE PLUS
 EXTERIOR CEILING
 MIAMI DADE CO NOA

SHEET
 3 OF 6

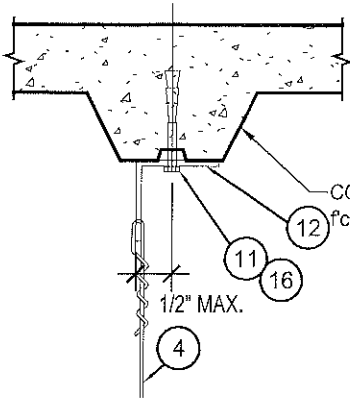

DETAIL 1

PRODUCT REVISED
 As complying with the Florida Building Code
 NOA-No. 24-1011.09
 Expiration Date: 10/20/2026
 By: Manuel Ferrer
 Miami-Dade Product Control

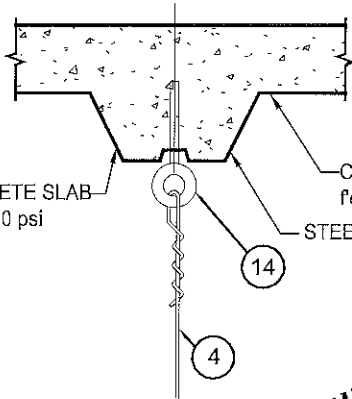

DETAIL 2

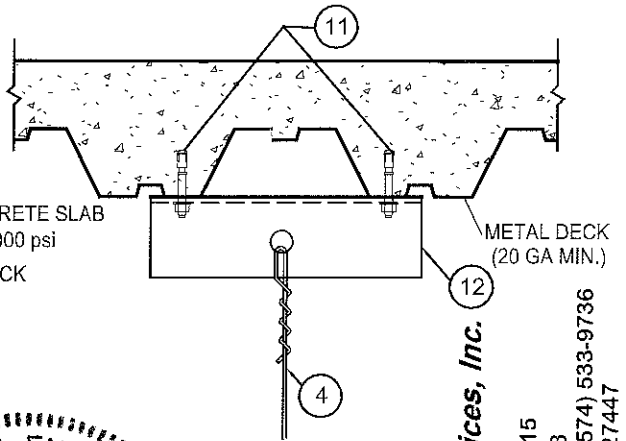

DETAIL 3

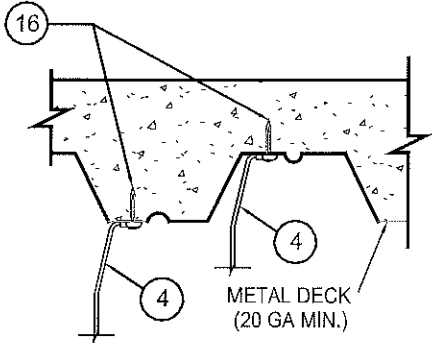

DETAIL 4

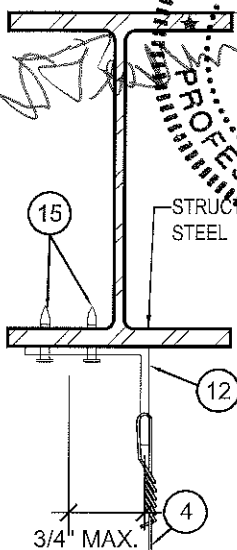

DETAIL 5

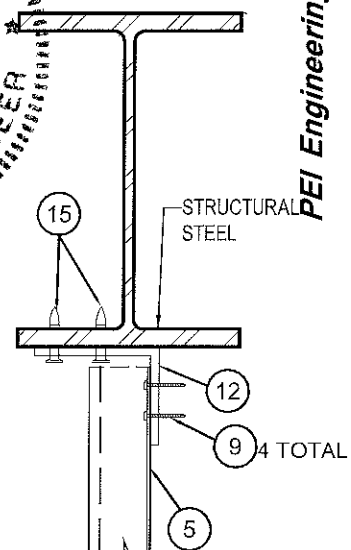

DETAIL 6

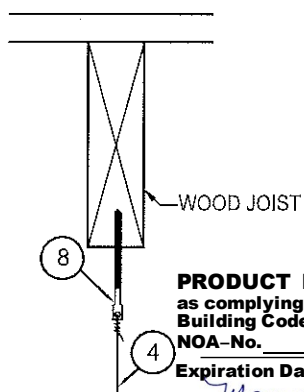

DETAIL 7

PRODUCT REVISED
 as complying with the Florida Building Code
 NOA-No. 21-0923.03
 Expiration Date: 10/20/2026
 By: Manuel Ferrer
 Miami-Dade Product Control

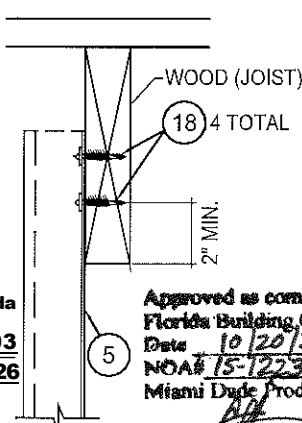

DETAIL 8

Approved as complying with the Florida Building Code
 Date: 10/20/2016
 NOA# 15-1223.05
 Miami Dade Product Control
 By: [Signature]

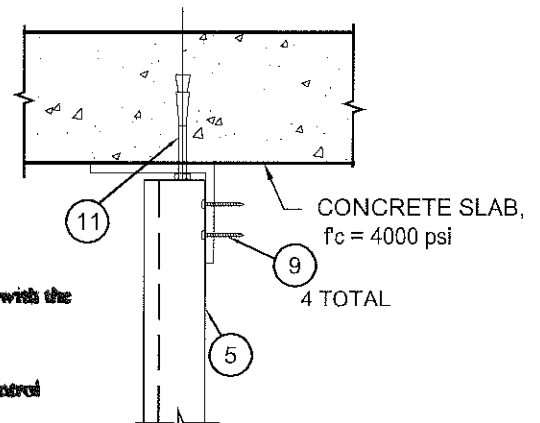

DETAIL 9

AUG 22 2016
Cal [Signature]

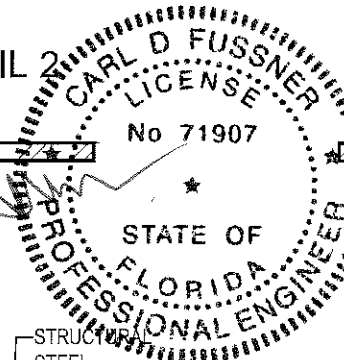

PEI Engineering Services, Inc.
 58640 State Road 15
 Goshen, IN 46528
 Phone: (574) 533-0337 - Fax: (574) 533-9736
 FL C.O.A. Number 27447

PRODUCT REVISED
 as complying with the Florida
 Building Code
 NOA-No. 21-0923.03
 Expiration Date: 10/20/2026
 By: Manuel Perez
 Miami-Dade Product Control

PEI Engineering Services, Inc.

58640 State Road 15
 Goshen, IN 46528
 Phone: (574) 533-0337 - Fax: (574) 533-9736
 FL C.O.A. Number 27447

Approved as complying with the
 Florida Building Code
 Date: 10/20/2016
 NOA: 15-1223.05
 Miami Dade Product Control

By: [Signature]

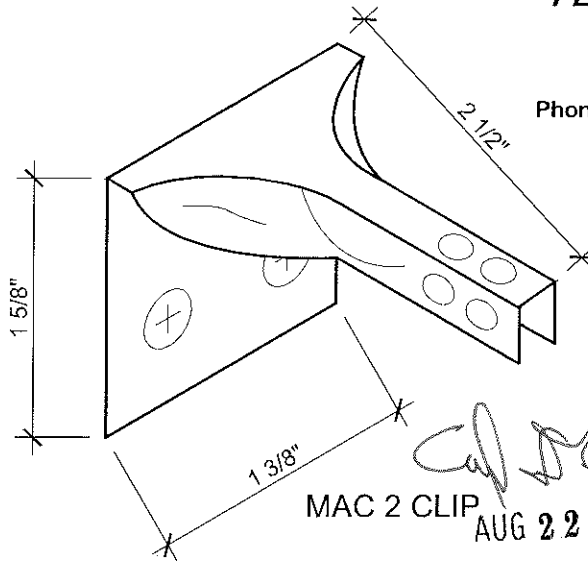

Carl D Fussner
 MAC 2 CLIP
 AUG 22 2016

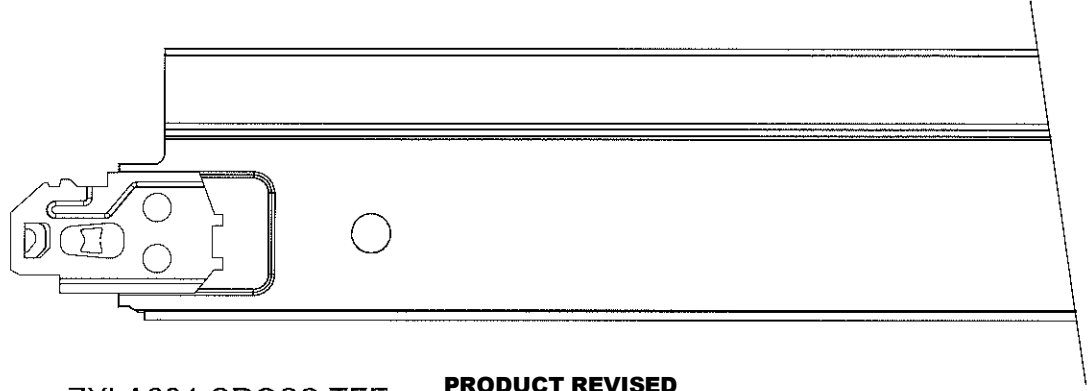
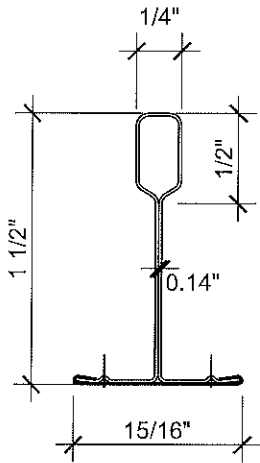
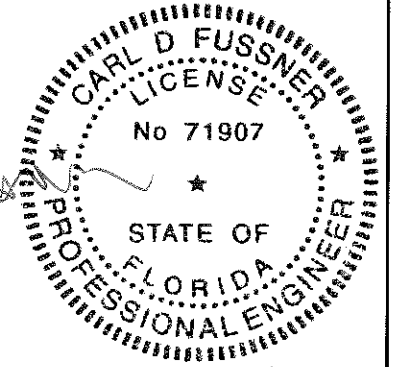

ZXL224 CROSS TEE

PRODUCT REVISED
 As complying with the Florida
 Building Code
 NOA-No. 24-1011.09
 Expiration Date: 10/20/2026
 By: Manuel Perez
 Miami-Dade Product Control

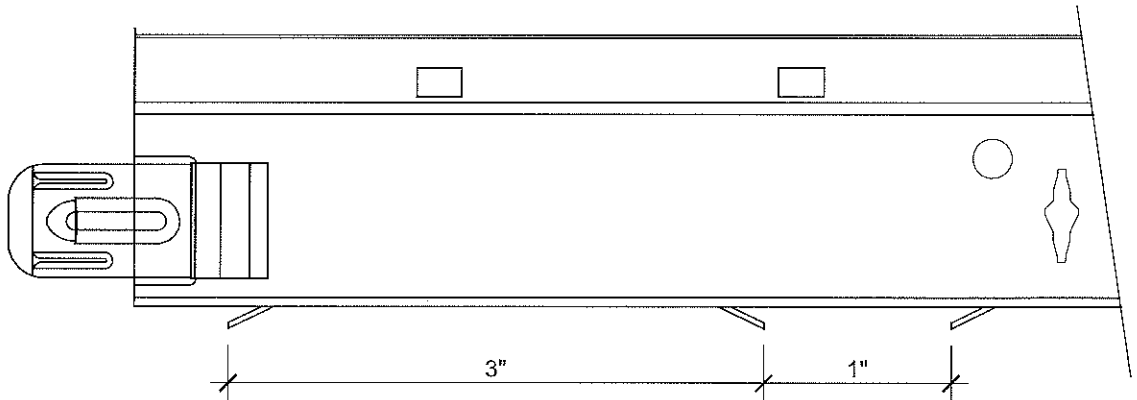
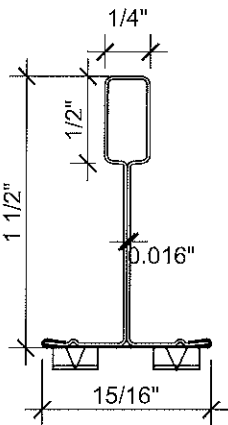

PARALOCK MAIL TEE



UNITED STATES
 GYPSUM CO.
 550 West Adams Street
 Chicago, Illinois 60661
 1-800-874-4968

DWG.# PAR-05
 DATE: 04/22/2016

COMPONENTS DETAILS
 PARALINE PLUS
 EXTERIOR CEILING
 MIAMI DADE CO NOA

SHEET
 5 OF 6

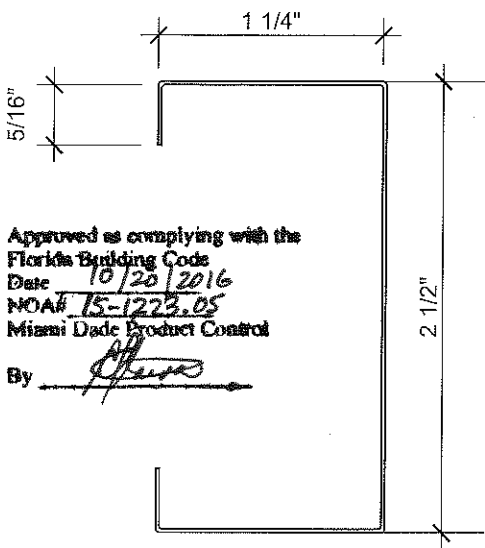

Approved as complying with the
Florida Building Code
Date 10/20/2016
NOA# 15-1223.05
Miami Dade Product Control
By [Signature]

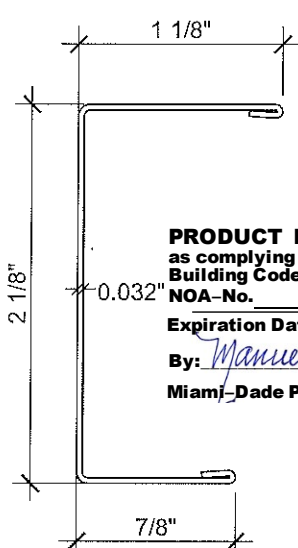

PRODUCT REVISED
as complying with the Florida
Building Code
NOA-No. 21-0923.03
Expiration Date: 10/20/2026
By: Manuel Perez
Miami-Dade Product Control

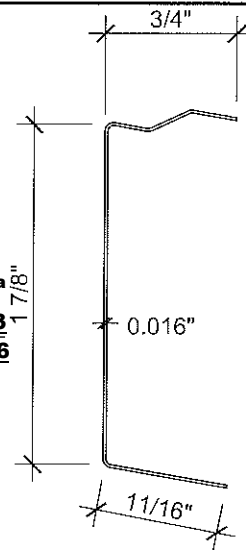

⑤ 250S125 22GA
METAL STUD
Fy = 33 KSI (MIN)

⑩ U 2-³/₃₂ CHANNEL
WALL MOLDING
PEI Engineering Services, Inc.

③ U 2-³/₃₂ HOLD-
DOWN CLIP

58640 State Road 15
Goshen, IN 46528
Phone: (574) 533-0337 - Fax: (574) 533-9736
FL C.O.A. Number 27447

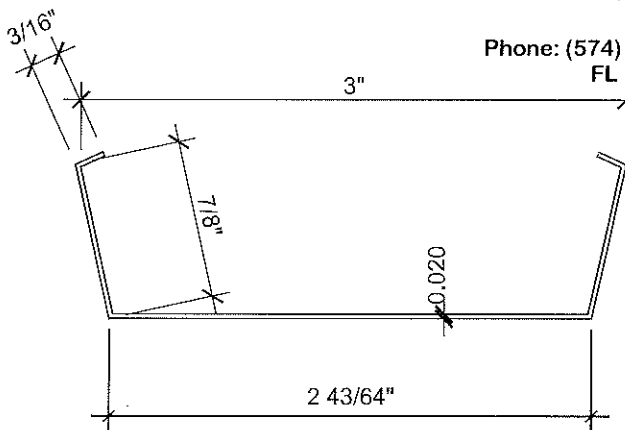

⑦ 3" PARALINE PLUS PAN,
ALUMINUM 3003 H24

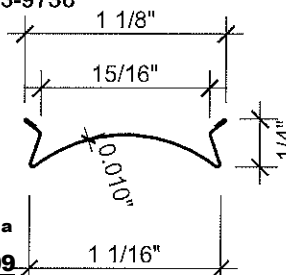

⑰ SNAP-LOC INSERT
ALUMINUM 3003 H24

PRODUCT REVISED
As complying with the Florida
Building Code
NOA-No. 24-1011.09
Expiration Date: 10/20/2026
By: Manuel Perez
Miami-Dade Product Control

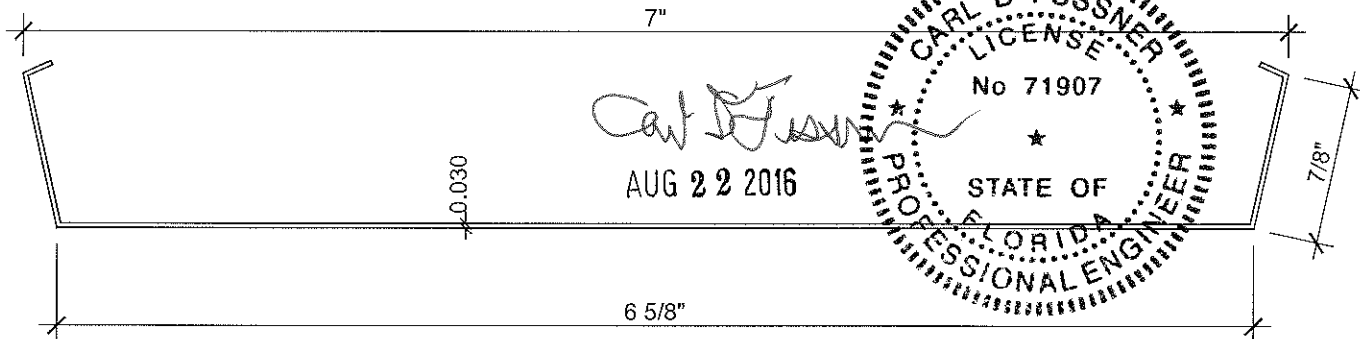

⑦ 7" PARALINE PLUS PAN, ALUMINUM 3003 H24

Carl D. Fussner
AUG 22 2016

