

Memorandum



Date: (Public Hearing: 6-4-24)
May 7, 2024

Agenda Item No. 5(F)

To: Honorable Chairman Oliver G. Gilbert, III
and Members, Board of County Commissioners

From: Daniella Levine Cava
Mayor

A handwritten signature in blue ink that reads "Daniella Levine Cava".

Subject: Ordinance Creating the Bridge Doral West Street Lighting Special Taxing District

Executive Summary

The purpose of this item is to gain authorization from the Board of County Commissioners (Board) to create a special taxing district in unincorporated Miami-Dade County (County) for the installation of streetlights and/or the maintenance of landscaping in the public Rights-of-Way.

Recommendation

It is recommended that the Board approve a petition submitted in accordance with Article 1, Chapter 18, of the Code of Miami-Dade County (Code) for the creation of the Bridge Doral West Street Lighting Special Taxing District (Special Taxing District), located within the boundaries of the City of Doral (City). The creation of this Special Taxing District is a subdivision requirement pursuant to Chapter 28 of the Code. Pursuant to section 1.01 of the Home Rule Charter and section 18-3.1 of the Code, this Board is vested with the power to designate the governing body of a municipality as the governing body of an existing special taxing district, if the municipality assumes any and all liabilities of the special taxing district. Therefore, it is also recommended that, upon creation of the Special Taxing District, the Board approve the attached Resolution and Interlocal Agreement authorizing the transfer and waiving by two-thirds (2/3) vote of the members present the requirement to hold an election approving said transfer. Waiver of election is appropriate in this case as no qualified electors reside within the Special Taxing District.

Scope

This proposed Special Taxing District lies within Commission District 12, which is represented by County Commissioner Juan Carlos Bermudez, and will provide street lighting services.

Fiscal Impact/Funding Source

Creation of this Special Taxing District will result in no economic impact to the Miami-Dade County (County) budget, and there will be no increase or decrease in County staffing. The developer, pursuant to Chapter 18 of the Code, is required to fund the Special Taxing District's first year's lease of the equipment and electricity costs to operate the street lighting system and all incidental costs incurred by the County for the creation and administration of the Special Taxing District.

After the first year, there will be a perpetual annual special assessment for the cost of street lighting to all property owners within the Special Taxing District. Florida Power and Light (FPL) is the owner of the system and will derive revenues from the creation of the Special Taxing District. FPL's contractors and subcontractors may increase their staffing levels to provide the service requirements created by this Special Taxing District.

Social Equity Statement

The proposed Ordinance creates the Special Taxing District, pursuant to Article I, section 1.01(A)(11) of the Miami-Dade County Home Rule Charter and Chapter 18 of the Code. The proposed Interlocal Agreement and concurring Resolution transfer the Special Taxing District, pursuant to section 18-3.1. If approved, the City will be the new governing body for the Special Taxing District, and property owners within the proposed Special Taxing District will pay special assessments appropriately apportioned according to the special benefit they received from the Special Taxing District's service, regardless of their demographics, and that the total estimated amount of the special assessment to be levied would not be in excess of such special benefit. The creation of this Special Taxing District, which was requested by 100% of the property owners, will provide for lighting continuity between contiguous Street Lighting Special Taxing Districts on connecting roadways, allow for higher intensity spotlighting at specific locations, and accommodate future County lighting standards.

Pursuant to section 18-20.2(b) of the Code regarding notice to purchasers of new residential property, it shall be the obligation of a seller of new residential property to provide the purchaser thereof with notice either of the existence of a special taxing district created pursuant to this Chapter of the Code or of a pending petition to create such a special taxing district. The notice shall be provided in the manner set forth in section 18-20.2 of the Code.

Track Record/Monitor

The Special Taxing District's creation and transfer will be managed by the Parks, Recreation and Open Spaces Department (PROS) and overseen by the Chief of the Special Assessment Districts Division (Division), Liset Romero-Lopez.

Delegation of Authority

This item authorizes the County Mayor or County Mayor's designee to execute the attached Interlocal Agreement to effectuate the transfer of the Special Taxing District upon its creation.

Background

In accordance with the provisions of Chapter 18 of the Code of the Code, a petition to create the Special Taxing District, duly signed by 100% of the owners of property within the proposed Special Taxing District, was filed with the Clerk of the Board. A copy of the petition was sent to the County Mayor and the County Attorney to examine and to file a written report with the Clerk certifying that such petition was sufficient in form and substance and signed and properly presented in accordance with the requirements of Chapter 18 of the Code. PROS compiled and filed with the Clerk a memorandum and accompanying written report and recommendations (Report), a copy of which is attached to this memorandum. The Report sets forth the boundaries of the Special Taxing District, an estimate of the cost of the improvements and/or services to be provided, the need for and desirability of the Special Taxing District, the ability of the affected properties to bear the special assessments, certifies that the improvements and/or services to be provided conform to the master plan of Miami-Dade County, and recommends that the Special Taxing District be created to provide a special benefit to all property within the proposed Special Taxing District.

Contingent upon Board approval of the creation and subsequent transfer of this Special Taxing District, the street lighting services will be accomplished pursuant to an agreement between the City and FPL. The facilities provided will remain the property of FPL. FPL will be responsible for the maintenance, repairs,

upgrades, and replacement of the light fixtures, lamps, poles, and all connecting service lines. The City will administer FPL's agreement, installation, and billing process.

- Boundaries:** On the North, NW 41 Street;
On the East, NW 112 Avenue;
On the South, Theoretical NW 33 Terrace;
On the West, Theoretical NW 113 Avenue.
- Number of Parcels:** 2 (Tentative plat proposes one tract, Tract A).
- Number of Owners:** 1
- Number of Owners with Homestead Exemption Signing Petition:** None – Bridge Point Doral 2700, LLC, the sole property owner and developer.
- Type of Improvements:** It is expected that the Special Taxing District will operate and maintain eleven (11) – Roadway (31,500 Lumens, 3,000K) cobra head LED streetlights mounted on concrete poles. At its discretion, the City reserves the right to adjust the quantity, style, and luminosity of the street lighting facilities, for reasons including, but not limited to, changes in field conditions, to address safety concerns, to provide for lighting continuity between contiguous Street Lighting Special Taxing Districts on connecting roadways, to allow higher intensity spotlighting at specific locations, and to accommodate future County lighting standards.
- Public Hearing Notification:** The Clerk will certify the place, date, and hour for a public hearing on the petition and the Report at which all interested persons will be afforded the opportunity to present for this Board's consideration their objections, if any, to the creation and establishment of the Special Taxing District. As pursuant to section 18-3(d), a public notice will be duly published in a newspaper of general circulation published in Miami-Dade County, Florida, and copies thereof will be mailed to all owners of taxable real property within the boundaries of the proposed Special Taxing District as their names and addresses appear on the latest Miami-Dade County Real Property Tax Roll.
- Preliminary Public Meeting:** None necessary.
- Required Referendum:** The creation of the Special Taxing District will be subject only to the Board's approval; no election will be

necessary as 100% of the property owners signed the petition. No election authorizing the transfer of the Special Taxing District will be necessary if waived by two-thirds (2/3) vote of the members present.

Estimated Completion: Fall 2024

Estimated Initial Billing: November 2024. Assessment billed annually as an itemized portion of the Real Property tax bill.

| | <u>First Year</u> | <u>Second Year</u> |
|--|-------------------|--------------------|
| Estimated Total District Costs: | \$35,736.26 | TBD |

Method of Apportionment: Front Footage

| | <u>First Year</u> | <u>Second Year</u> |
|---|-------------------|--------------------|
| Estimated Annual District Assessments: | | |
| Per Assessable Front Foot: | Costs to be | TBD |
| For Tract A: | provided by | TBD |
| | Petitioner | |

The above annual costs and assessment information are based on the expected lighting services to be provided by the Special Taxing District, and are subject to change in the event that the Special Taxing District's services are adjusted by the City as provided herein. Each subsequent year will be calculated based on actual cost.

State or federal grants are not applicable to this Special Taxing District.

Each Street Lighting Special Taxing District is unique due to its geographical boundaries, affected property owners, and level of service to be provided. Creation of a new Special Taxing District to provide this service is the best and most cost-effective method to achieve this benefit.

In accordance with the requirements of Chapter 28 of the Code to provide street lighting in new subdivisions through the creation of Street Lighting Special Taxing Districts, and in compliance with the provisions of section 18-3(c) and section 18-3.1 of the Code, I have reviewed the facts submitted by PROS in its Report and Recommendations, a copy of which is attached and incorporated herein. I concur with their recommendation that this Special Taxing District be created pursuant to section 18-2 of the Code and transferred to the City.

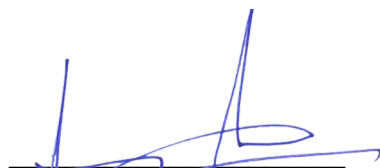

Jimmy Morales
Chief Operations Officer

**REPORT AND RECOMMENDATIONS ON THE
CREATION AND TRANSFER OF BRIDGE DORAL WEST
STREET LIGHTING SPECIAL TAXING DISTRICT
MIAMI-DADE COUNTY, FLORIDA**

Pursuant to Chapter 18 of the Code of Miami-Dade County (Code), and as a result of a detailed investigation of a duly petitioned for Special Taxing District, the following facts are submitted by the Miami-Dade County Parks, Recreation and Open Spaces Department (PROS) Director concerning the creation and transfer of Bridge Doral West Street Lighting Special Taxing District (Special Taxing District).

1. BOUNDARIES OF THIS DISTRICT

The proposed Special Taxing District is located entirely within the municipal limits of the City of Doral, Florida (City). Pursuant to Chapter 18 of the Code, Miami-Dade County has received approval from the City to create and transfer this Special Taxing District per Resolution No. 23-182, a copy of which is attached, and the boundaries, as set forth in the petition, are as follows:

Parcels of land lying in Section 30, Township 53 South, Range 40 East, Miami-Dade County, Florida (a.k.a. Bridge Doral West, Tentative Plat #T-24917); being more particularly described as follows:

Those portions of the E3/5 of Section 30, Township 53 South, Range 40 East, Miami-Dade County, Florida, less the north 55.00 and the south 2,795.85 feet thereof, being more particularly described as follows:

Parcel 1

Beginning at the intersection of the west line of the NE1/4 of said Section 30 with a line lying 55.00 feet south and parallel to the north line of said NE1/4 of Section 30; thence N89°34'32"E along said parallel line thence 38.70 feet; thence S00°25'28"E 2039.53 feet; thence S01°34'32"W 301.57 feet; thence S88°15'10"W 5.00 feet; thence S01°42'44"E 50.54 feet to a point on the arc of a circular curve concave southwesterly from which a radial line bears S88°15'10"W; thence northwesterly along the arc of said curve to the left also being the north Right-of-Way line of NW 34th Street, having a radius of 105.00 feet and a central angle of 88°40'29", for an arc distance of 162.50 feet to a point of tangency; thence S89°34'41"W along said north Right-of-Way line 390.06 feet to a point on the west line of said E3/5 of Section 30; thence N01°44'50"W along said west line 2289.61 feet to a point on a line lying 55.00 feet south and parallel to the north line of the NW1/4 of said Section 30; thence N89°34'42"E along said parallel line 523.57 feet to the Point of Beginning.

And

Parcel 2

Beginning at the southwest corner of said E3/5 of Section 30, Township 53 South, Range 40 East, less the south 2,795.85 feet thereof; thence N01°44'50"W along the west line of said E3/5 of Section 30 for 68.99

feet to a point on the south Right-of-Way line of NW 34th Street; thence along said south Right-of-Way line the following three (3) courses and distances: (1) N89°34'41"E 363.78 feet to a point of curvature of a circular curve to the right; thence southeasterly along the arc of said curve, having a radius of 50.00 feet and a central angle of 88°40'29", for an arc distance of 77.38 feet to a point of tangency; thence S01°44'50"E 20.45 feet to a point on the north line of said south 2,795.85 feet of Section 30; thence S89°37'22"W along said line 412.65 feet to the Point of Beginning.

The Special Taxing District’s boundaries and geographical location are shown on the attached sketch entitled Bridge Doral West Street Lighting Special Taxing District and hereinafter referred to as “Exhibit A”.

2. LOCATION OF THE INSTALLATIONS TO BE CONSTRUCTED

Services to be provided under the Special Taxing District will consist of public street lighting located within public rights-of-way.

3. ESTIMATED COSTS AND ANNUAL EXPENSE FOR MAINTENANCE, REPAIR AND OPERATION OF THIS DISTRICT

The cost of streetlights in this Special Taxing District will be continual and is based on a preliminary estimate using Rate Schedule No. LT – 1 prepared by Florida Power and Light (FPL) and approved by the Florida Public Service Commission, a copy of which is attached. FPL will install the lights, poles, and service lines at its expense and the facilities will remain the property of FPL. FPL will also be responsible for the maintenance, repairs, upgrades, and replacement of the light fixtures, lamps, poles, and all connecting service lines. However, the developers, through the Special Taxing District, may be required to pay a differential cost if rapid construction techniques cannot be used on this Special Taxing District and this cost is shown in the Special Taxing District's cost estimate below.

| <u>Estimated Annual District Costs:</u> | <u>First Year</u> | <u>Second Year</u> |
|--|--------------------------|---------------------------|
| 11 – 31,500 Lumens, 3000K LED Luminaires | \$1,605.12 | TBD |
| 11 – Concrete poles | \$1,082.40 | TBD |
| 1,980 Ft. – Underground Wiring | \$2,676.99 | TBD |
| Annual Fuel Adjustments (Based on 12,276 KWH at \$0.07443 Per KWH) | \$913.70 | TBD |
| Franchise Cost (Based on 9.2970% of \$6,248.84) | \$583.69 | TBD |
| FPL Restoration Costs | \$3,300.00 | TBD |

| <u>Estimated Annual District Costs (Cont'd):</u> | <u>First Year</u> | <u>Second Year</u> |
|---|---------------------------|---------------------------|
| FPL Additional Lighting Charge Costs | \$99.00 | TBD |
| Boring | \$8,910.00 | TBD |
| Contingencies | <u>\$3,834.18</u> | TBD |
| Total Street Lighting Service Costs | \$23,005.08 | TBD |
| Engineering & Administrative Costs | \$6,126.18 | TBD |
| Billing, Collecting & Processing Costs | <u>\$6,605.00</u> | TBD |
| Total Costs Covered by Petitioner | \$35,736.26 | |
| Total Costs to District | | TBD |
| | | |
| <u>Estimated Annual District Assessments:</u> | <u>First Year</u> | <u>Second Year</u> |
| Per Assessable Front Foot: | Costs to be | TBD |
| For Tract A: | provided by petitioner | TBD |

The above annual costs and assessment information are based on the expected lighting services to be provided by the Special Taxing District and are subject to change in the event the Special Taxing District's services are adjusted by the City. Total costs and assessments will be adjusted, if necessary, to meet actual costs.

4. CONFORMITY TO THE MASTER PLAN OF MIAMI-DADE COUNTY

The proposed Special Taxing District conforms to and in no way conflicts with the master plan of development for Miami-Dade County (County) (see attached memorandum from the Department of Regulatory and Economic Resources (RER)).

5. RECOMMENDATION CONCERNING THE DESIRABILITY OF THIS DISTRICT

The need for street lighting in the County is apparent. Residents and property owners of the County continue to demonstrate their desire for street lighting through numerous petitions and personal requests. The ability of the affected properties to pay special assessments is evident since the costs of the Special Taxing District's services, including any bonds then outstanding, do not exceed 25% of the assessed valuation of all properties within the Special Taxing District's boundaries (including homesteads) as shown by the last preceding assessment roll of the County. In my opinion, the streetlights installed pursuant to the creation of this Special Taxing District will provide special benefits to properties within the Special Taxing District's boundaries exceeding the amount of special assessments to be levied.

6. PROCEDURE

As provided for under Chapter 18 of the Code, the property owners, the developers, within the

proposed Special Taxing District shall guarantee payment of all costs and expenses incidental to the creation of such Special Taxing District and shall pay the entire cost of providing street lighting within the Special Taxing District for the first year. Based on front footage, each property owner within the proposed Special Taxing District will pay the City, through a special assessment, a proportionate share of the total annual costs for the second year and each year thereafter.

In the event actual second year costs are lower than the costs estimated herein, the City shall adjust and decrease the front foot rate of assessment. In the event actual second year costs are higher than estimated herein, the front foot rate of the assessment shall not be increased prior to the City Council adopting a revised assessment roll.

Following the creation of the Special Taxing District by the Board, the petitioner's plat shall not be placed on a Commission agenda for approval prior to receipt of the payment from the developers for the first year costs as specified in Item 3 above. Upon adoption of the petitioner's plat by the Board and subsequent transfer to the City, the City may then enter into an agreement with FPL, wherein the City will pay to FPL any costs associated with the streetlight installation and ongoing costs of service.

7. RECOMMENDATION

It is recommended that Bridge Doral West Street Lighting Special Taxing District be created and transferred pursuant to sections 18-22.1 and 18-3.1 of the Code, which provides for the creation of Special Taxing Districts for street lighting in new subdivisions. The creation and transfer of this Special Taxing District will be subject to Board approval only; no election will be necessary as 100% of the property owners signed the petition. I also recommend that the County Attorney cause to be prepared an ordinance authorizing the creation of the Bridge Doral West Street Lighting Special Taxing District. Pursuant to Chapter 18 of the Code, the Board shall receive and hear, at a public hearing, remarks by interested persons on this Special Taxing District, and thereafter may adopt such ordinance. Following adoption of the creating ordinance, it is further recommended that the Board adopts the transfer of the Special Taxing District to the City by waiving by two-thirds (2/3) vote of the members present the requirement to hold an election approving said transfer. Adoption of this transfer resolution will designate the City as the governing body of the Special Taxing District. The ordinance creating the Special Taxing District together with the transfer resolution shall take effect ten days after the date of its adoption unless vetoed by the Mayor, and if vetoed, it shall become effective only upon an override by the Board. My office will also be available to answer any questions from the public or your office in regard to the financial and/or engineering facts of this Special Taxing District. We further recommend that the County Mayor or County Mayor's designee forward the attached report to the Board after review and concurrence with our findings.

- Attachments: (1) Copy of Petition and Attachments
(2) Copy of Resolution from the City of Doral
(3) Copy of Interlocal Agreement
(4) Copy of FPL Rate Schedule No. LT-1
(5) Copy of Memo from Department of Regulatory and Economic Resources
(6) District Boundaries and Geographical Location Sketch (Exhibit A)

**MIAMI-DADE COUNTY ATTORNEY'S OFFICE
M E M O R A N D U M**

TO: Liset Romero-Lopez
Chief, Special Assessment Districts Division

FROM: Ryan Carlin *RC*
Assistant County Attorney

DATE: February 4, 2024

SUBJECT: Bridge Doral West Street Lighting Special Taxing District

Please be advised that I have reviewed the above referenced petition and find it to be legally sufficient for street lighting purposes only.

Memorandum



Date: February 1, 2024

To: Basia Pruna, Deputy Clerk
Office of the Clerk of the Board
Attn: Shania Momplaisir

From: Liset Romero-Lopez, Chief *LRL*
Special Assessment Districts Division
Parks, Recreation and Open Spaces Department

Subject: Bridge Doral West Street Lighting Special Taxing District

In reference to the subject petition, we hereby certify that, in compliance with Section 18-2 of the Miami-Dade County Code, this Department has verified the attached name against the records of the Office of the Property Appraiser, and has concluded that said petition relates to real property in a new subdivision and the signator is an owner and/or individual signing in his official capacity as representative of the owner of the property in question. We are therefore submitting the following information:

- | | | |
|----|--|-------------|
| 1. | Total number of parcels of land within district boundaries | <u>2</u> |
| 2. | Total number of owners of property within district boundaries | <u>1</u> |
| 3. | Total number of resident owners within district boundaries (this is a new subdivision area) | <u>0</u> |
| 4. | Total number of signatures on the petition | <u>1</u> |
| 5. | Total number of owners or representatives signing the petition in an official capacity | <u>1</u> |
| 6. | Percentage of owners or representatives signing the petition in their official capacity | <u>100%</u> |

Pursuant to Section 18-2 of the Code, this is a valid petition.

By copy of this memorandum, I am forwarding this petition for review by the County Attorney for legal sufficiency.

Attachment

cc: Ryan Carlin

PARKS, RECREATION AND OPEN SPACES DEPARTMENT
SPECIAL ASSESSMENT DISTRICTS DIVISION

7/7/23

Document Preparation
Date

Departmental Acceptance Date
(Government Use Only)

PETITION FOR STREETLIGHTING SPECIAL TAXING DISTRICT

To the Board of County Commissioners of Miami-Dade County, Florida:

We, the undersigned property owner(s), do hereby petition Miami-Dade County, Florida, for the creation of the Special Taxing District(s) required by the respective plat(s) pursuant to Chapter 18 of the Code of Miami-Dade County, Florida, for any or all of the following: installation, operation and maintenance of Light Emitting Diode (LED) of an intensity of 5,000 up to 50,000 lumens, mounted on concrete, fiber glass or existing poles. The petitioned for district lies within that portion of the unincorporated area of Miami-Dade County more fully described on the attached Exhibit A.

Tentative Plat(s) Name(s) and Number Bridge Doral West T24917

It is understood and agreed that the boundaries of this district and the type and level of services to be provided by this district will be reviewed by the appropriate County authorities. It is also understood that the streetlights to be provided shall be in accordance with minimum standards and requirements set forth by the Miami-Dade County Parks, Recreation and Open Spaces Department.

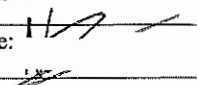
| OWNER'S NAME & SIGNATURE | OWNER'S ADDRESS | LEGAL DESCRIPTION OF PROPERTY | TAX FOLIO NUMBER |
|---|----------------------------|-------------------------------|------------------|
| Bridge Point Doral 2700, LLC | 9525 W. Bryn Mawr, Ste 700 | | 35-3030-000-0020 |
| Nick Siegel, Vice President | Rosemont, IL 60018 | | 35-3030-000-0025 |
| Signature:  | | | |
| | | MORE FULLY | |
| | | DESCRIBED ON | |
| | | THE ATTACHED | |
| | | "EXHIBIT A" | |
| | | | |
| | | | |
| | | | |

STATE OF Florida
COUNTY OF Broward

I HEREBY CERTIFY that on this day, before me, an officer duly qualified to take acknowledgments, personally appeared Nick Siegel, the Vice President of Bridge Point Doral 2700, LLC, a Delaware limited liability company() personally, known to me, or () who produced identification in the form of license, and who executed the foregoing instrument and acknowledged before me that Nick Siegel executed the same for the purposes herein expressed.

WITNESS my hand and official seal in the County and State last aforesaid, this 7th day of July, 2023.

(SEAL)



RACHEL S. ROSS
Commission # HH 133839
Expires July 10, 2025
Bonded Thru Budget Notary Services

Notary Public, State of Illinois

My Commission Expires: 7/10/25

 DEPARTMENTAL ACCEPTANCE DATE
 (GOVERNMENT USE ONLY)

EXHIBIT "A"

EXHIBIT A TO THE PETITION FOR THE PLAT KNOWN AS
BRIDGE DORAL WEST DATED 7/7/23 FOR THE
 CREATION OF STREET LIGHTING SPECIAL TAXING DISTRICT.

Legal Description:

THOSE PORTIONS OF THE EAST 3/5 OF SECTION 30, TOWNSHIP 53 SOUTH, RANGE 40 EAST, MIAMI-DADE COUNTY, FLORIDA, LESS THE NORTH 55.00 AND THE SOUTH 2,795.85 FEET THEREOF, BEING MORE PARTICULARLY DESCRIBED AS FOLLOWS:

PARCEL 1

BEGINNING AT THE INTERSECTION OF THE WEST LINE OF THE NORTHEAST 1/4 OF SAID SECTION 30 WITH A LINE LYING 55.00 FEET SOUTH AND PARALLEL TO THE NORTH LINE OF SAID NORTHEAST 1/4 OF SECTION 30; THENCE NORTH 89°34'32" ALONG SAID PARALLEL LINE THENCE 38.70 FEET; THENCE SOUTH 00°25'28" EAST 2039.53 FEET; THENCE SOUTH 01°34'32" WEST 301.57 FEET; THENCE SOUTH 88°15'10" WEST 5.00 FEET; THENCE SOUTH 01°42'44" EAST 50.54 FEET TO A POINT ON THE ARC OF A CIRCULAR CURVE CONCAVE SOUTHWESTERLY FROM WHICH A RADIAL LINE BEARS SOUTH 88°15'10" WEST; THENCE NORTHWESTERLY ALONG THE ARC OF SAID CURVE TO THE LEFT ALSO BEING THE NORTH RIGHT-OF-WAY LINE OF NW 34TH STREET, HAVING A RADIUS OF 105.00 FEET AND A CENTRAL ANGLE OF 88°40'29", FOR AN ARC DISTANCE OF 162.50 FEET TO A POINT OF TANGENCY; THENCE SOUTH 89°34'41" WEST ALONG SAID NORTH RIGHT-OF-WAY LINE 390.06 FEET TO A POINT ON THE WEST LINE OF SAID EAST 3/5 OF SECTION 30; THENCE NORTH 01°44'50" WEST ALONG SAID WEST LINE 2289.61 FEET TO A POINT ON A LINE LYING 55.00 FEET SOUTH AND PARALLEL TO THE NORTH LINE OF THE NORTHWEST 1/4 OF SAID SECTION 30; THENCE NORTH 89°34'42" EAST ALONG SAID PARALLEL LINE 523.57 FEET TO THE POINT OF BEGINNING.

AND:

PARCEL 2

BEGINNING AT THE SOUTHWEST CORNER OF SAID EAST 3/5 OF SECTION 30, TOWNSHIP 53 SOUTH, RANGE 40 EAST, LESS THE SOUTH 2,795.85 FEET THEREOF; THENCE NORTH 01°44'50" WEST ALONG THE WEST LINE OF SAID EAST 3/5 OF SECTION 30 FOR 68.99 FEET TO A POINT ON THE SOUTH RIGHT-OF-WAY LINE OF NW 34TH STREET; THENCE ALONG SAID SOUTH RIGHT-OF-WAY LINE THE FOLLOWING THREE (3) COURSES AND DISTANCES: (1) NORTH 89°34'41" EAST 363.78 FEET TO A POINT OF CURVATURE OF A CIRCULAR CURVE TO THE RIGHT; THENCE SOUTHEASTERLY ALONG THE ARC OF SAID CURVE, HAVING A RADIUS OF 50.00 FEET AND A CENTRAL ANGLE OF 88°40'29", FOR AN ARC DISTANCE OF 77.38 FEET TO A POINT OF TANGENCY; THENCE SOUTH 01°44'50" EAST 20.45 FEET TO A POINT ON THE NORTH LINE OF SAID SOUTH 2,795.85 FEET OF SECTION 30; THENCE SOUTH 89°37'22" WEST ALONG SAID LINE 412.65 FEET TO THE POINT OF BEGINNING.

SAID LANDS LYING AND BEING IN THE CITY OF DORAL, MIAMI-DADE COUNTY, AND CONTAINING 1,256,051 SQUARE FEET (28.8350 ACRES), MORE OR LESS.

Folio No(s): 35-3030-000-0020 and 35-3030-000-0025

RESOLUTION No. 23-182

A RESOLUTION OF THE MAYOR AND THE CITY COUNCIL OF THE CITY OF DORAL, FLORIDA, AMENDING RESOLUTION No. 23-49 TO INCLUDE PLAT NUMBER T-24925 IN ADDITION TO T-24917 AS REQUESTED BY MIAMI-DADE COUNTY; RESOLUTION No. 23-49 SUPPORTS THE CREATION OF A LIGHTING SPECIAL TAXING DISTRICT FOR BRIDGE DORAL WEST (T-24917); AUTHORIZING THE CITY MANAGER TO AMEND THE RESOLUTION; PROVIDING FOR IMPLEMENTATION; AND PROVIDING FOR AN EFFECTIVE DATE

WHEREAS, Miami-Dade County has recommended the need for the creation of a Special Taxing District for the purpose of providing lighting within the Bridge Doral West (Bridge Point) development along NW 112th Avenue between NW 34th Street and NW 41st Street, and along NW 34th Street approximately 450 feet west of NW 112th Avenue; and

WHEREAS, Miami-Dade County adopted section 18-3.1, Miami-Dade County Code, which allows the County and a municipality, by joint resolutions, to designate the governing body of such municipality as the governing body of a new Special Taxing District created wholly within the boundaries of such municipality; and

WHEREAS, the Bridge Doral West development is located entirely within the City of Doral; and

WHEREAS, the City of Doral expresses its support for the creation and establishment of a lighting Special Taxing District for the Bridge Doral West development (T-24917 & T-24925) along NW 112th Avenue between NW 34th Street and NW 41st Street, and along NW 34th Street approximately 450 feet west of NW 112th Avenue, and hereby requests transfer of control and operations of the district upon its creation by Miami-Dade County; and

WHEREAS, Resolution No. 23-49 was adopted by the Mayor and the Councilmembers on April 12, 2023, supporting the creation of the Lighting Special Taxing District and authorizing the City Manager to enter into an interlocal agreement with Miami-Dade County for the creation and transfer of said district; and

WHEREAS, on September 22, 2023, at a progress meeting with the Developer, the City was advised that Miami-Dade County requested Plat Number T-24925 to be included in the Resolution in addition to plat number T-24917 already included; and

WHEREAS, the next steps in the process are for the Board of County Commissioners to establish the Bridge Doral West Special Taxing District (T-24917 & T-24925), adopt a resolution authorizing the transfer of the district to the City of Doral, and execution of an interlocal agreement between the City and the County relating to the transfer of the district; and

WHEREAS, staff respectfully requests authorization from the Mayor and the City Councilmembers to authorize the City Manager to amend Resolution No. 23-49 to include plat number T-24925 in the Resolution language as requested by Miami-Dade County in addition to the originally included T-24917.

NOW, THEREFORE, BE IT RESOLVED BY THE MAYOR AND THE CITY COUNCIL OF THE CITY OF DORAL AS FOLLOWS:

Section 1. Recitals. The above recitals are confirmed, adopted, and incorporated herein and made part hereof by this reference.

Section 2. Approval. The amendment to Resolution No. 23-49 to include plat number T-24925 in the Resolution language as requested by Miami-Dade County in addition to the originally included T-24917 is hereby approved.

Section 3. Authorization. The City Manager is authorized to amend the Resolution and execute the interlocal agreement for transfer of the Bridge Point Doral Special Taxing District upon its creation.

Section 4. Implementation. The City Manager and the City Attorney are hereby authorized to take such further action as may be necessary to implement the purpose and the provisions of this Resolution.

Section 5. Effective Date. This Resolution shall take effect immediately upon adoption.

The foregoing Resolution was offered by Councilmember Puig-Corve who moved its adoption. The motion was seconded by Vice Mayor Pineyro and upon being put to a vote, the vote was as follows:

| | |
|-----------------------------|-----|
| Mayor Christi Fraga | Yes |
| Vice Mayor Rafael Pineyro | Yes |
| Councilwoman Digna Cabral | Yes |
| Councilwoman Maureen Porras | Yes |
| Councilman Oscar Puig-Corve | Yes |

PASSED AND ADOPTED this 18 day of October, 2023.



CHRISTI FRAGA, MAYOR

ATTEST:



CONNIE DIAZ, MMC
CITY CLERK

APPROVED AS TO FORM AND LEGAL SUFFICIENCY
FOR THE USE AND RELIANCE OF THE CITY OF DORAL ONLY:



VALERIE VICENTE, ESQ. for
NABORS, GIBLIN & NICKERSON, P.A.
CITY ATTORNEY

TRANSFER OF THE BRIDGE DORAL WEST NW 112TH AVENUE AND NW 34TH STREET, STREET LIGHTING SPECIAL TAXING DISTRICT FROM MIAMI-DADE COUNTY TO THE CITY OF DORAL

THIS AGREEMENT FOR TRANSFER OF THE BRIDGE DORAL WEST NW 112TH AVENUE AND NW 34TH STREET, STREET LIGHTING SPECIAL TAXING DISTRICT TO BE CREATED BY MIAMI-DADE COUNTY (AGREEMENT), made and entered into this ____ day of _____, 2023, by and between the **CITY OF DORAL, FLORIDA**, a municipal corporation of the STATE OF FLORIDA (hereinafter referred to as the “City”) and **MIAMI-DADE COUNTY**, a political subdivision of the STATE OF FLORIDA (hereinafter referred as the “County”).

WITNESSETH

WHEREAS, the City has requested the creation and immediate transfer of control of the Bridge Doral West (Bridge Point) Street Lighting Special Taxing District (“**Special Taxing District**”) from the County to the City such that the City Mayor and City Council will become the governing body responsible for the Special Taxing District; and

WHEREAS, the Special Taxing District shall be created along NW 112th Avenue between NW 34th Street and NW 41st Street, and along NW 34th Street approximately 450 feet west of NW 112th Avenue; and

WHEREAS, the City and the County are mutually desirous of transferring the Special Taxing District to the City; and

WHEREAS, the County is immediately transferring the Special Taxing District to the City upon creation, and therefore the County will not establish or provide any services or assets to the Special Taxing District; and

WHEREAS, the City shall take full responsibility for the operation and maintenance of the Special Taxing District as determined herein, including exclusive responsibility for all pre-existing and future liabilities, whether known or unknown,

NOW, THEREFORE, in consideration of the covenants herein provided, the City of Doral and Miami-Dade County agree as follows:

1. The foregoing recitals are incorporated herein.
2. This Agreement shall become effective if passed pursuant to a joint resolution of the City and County transferring the Special Taxing District (“**Transfer Date**”).
3. As of the Transfer Date, the Board of County Commissioners will no longer be the governing body of the Special Taxing District and the City Mayor and City Council shall be the governing board of the Special Taxing District.

4. Prior to the Transfer Date, the County's involvement with the Special Taxing District shall be exclusively administrative to effectuate the creation and immediate transfer of the Special Taxing District to the City.
5. On Transfer Date, the County will cease all involvement, and the City will be exclusively responsible for the Special Taxing District.
6. Beginning on the Transfer Date, the City shall be responsible for all pre-existing and future liabilities of the Special Taxing District, whether known or unknown.
7. The City shall be responsible for establishing assessment rates and collecting assessments for the Special Taxing District. If the City intends on using the uniform method for the levy, collection, and enforcement of non-ad valorem assessments, the City shall comply with the requirements of section 197.3632 of the Florida Statutes and shall make such arrangements with the Miami-Dade County Office of the Property Appraiser and Miami-Dade County Tax Collector.
8. The City shall be responsible for arranging for the Special Taxing District's utility accounts and procuring contracts with vendors to provide all necessary services to the Special Taxing District, including, but not limited to, the installation of street lights or other improvements.
9. The City shall be responsible for establishing its own protocols and policies for administration and assessment of the Special Taxing District.
10. The City shall be responsible for the continuous operation, maintenance, repair, and replacement, when necessary, of the Special Taxing District's improvements.
11. The City shall be responsible for payment of all of the Special Taxing District's expenses. It is provided, however, that such payment of the Special Taxing District's expenses incurred by the City are properly chargeable to the Special Taxing District.
12. Within sixty (60) days of the Transfer Date, the County shall provide to the City a final financial reconciliation of all known liabilities for the Special Taxing District. Any omission from the final reconciliation shall not constitute a waiver by either the County or the City for payment to or from the Special Taxing District's account.
13. The County shall issue an invoice to the City for any deficit in the Special Taxing District's account, including, but not limited to, the costs to establish the Special Taxing District. The City shall pay the invoice within sixty (60) days of receipt. It is provided, however, that such expenses incurred by the City are properly chargeable to the Special Taxing District.
14. Pursuant to section 2-8.9 of the Code of Miami-Dade County, the City is encouraged to pay the Living Wage.

15. To the extent allowed by, and subject to the limitations of, section 768.28 of the Florida Statutes, the City does hereby agree to indemnify and hold the County, its officials, employees and instrumentalities, harmless from any and all liability for any damage, injury, or claim that may arise by virtue of the Special Taxing District, or the exercise of any rights, obligations or actions under this Agreement, including, but not limited to, the City's operation of the Special Taxing District or the City's failure to provide services or maintain, repair, replace, or operate the improvements.
16. The undersigned further agrees that these conditions shall be deemed a continuing obligation between the City and the County and shall remain in full force and effect and be binding on the City, and any permitted successors or assigns.
17. In the event that the City requests any third party to assume any of the responsibilities hereunder, the City acknowledges that such assumption shall not relieve the City from any obligations or responsibilities hereunder. Any failure by any third party shall not subject the County to any liability for any damage, injury, or claim that may arise.
18. Nothing in this Agreement, expressed or implied, is intended to: (a) confer upon any entity or person other than the parties and any permitted successors or assigns, any rights or remedies under or by reason of the Agreement as a third party beneficiary or otherwise except as specifically provided in this Agreement; or (b) authorize anyone not a party to this Agreement to maintain an action pursuant to or based upon this Agreement. Additionally, nothing herein shall be deemed to constitute a waiver of any rights under section 768.28 of the Florida Statutes, or as a waiver of the County's or City's sovereign rights.
19. The language agreed to herein expresses the mutual intent and agreement of the County and the City, and shall not, as a matter of judicial construction, be construed more severely against one of the parties from the other.
20. Any notices to be given hereunder shall be in writing and shall be deemed to have been given if sent by hand delivery, recognized overnight courier (e.g., Federal Express), or by written certified U.S. mail, with return receipt requested, addressed to the Party for whom it is intended, at the place specified. The method of delivery shall be consistent among all of the persons listed herein. For the present, the City and County designate the following as the respective places for notice purposes:

FOR THE COUNTY:

Miami-Dade County Mayor
111 NE 1st Street, Suite 2910,
Miami, FL 33128

FOR THE CITY:

City of Doral
Attn: City Manager
8401 NW 54 Terrace
Doral, FL 33166

With a Copy to:

Miami-Dade PROS Director
275 NW 2nd Street, 5th Floor,
Miami, FL 33128

Miami-Dade County Attorney's Office,
111 NE 1st Street, Suite 2810,
Miami, FL 33128

With a Copy to:

City of Doral
Attn: City Attorney
8401 NW 54 Terrace
Doral, FL 33166

FOR CITY OF DORAL, a municipal corporation:

B.H.
BARBARA HERNANDEZ
CITY MANAGER

ATTEST:

Connie Diaz
CITY CLERK
PRINT NAME: Connie Diaz

APPROVED AS TO FORM AND LEGAL SUFFICIENCY:

Valerie Vicente
NABORS, GIBLIN & NICKERSON, P.A.
CITY ATTORNEY

**FOR THE MIAMI-DADE COUNTY BOARD OF COUNTY COMMISSIONERS,
FLORIDA:**

ATTEST:

BY: _____
MAYOR OR MAYOR'S DESIGNEE

DATE

HARVEY RUVIN, CLERK

BY: _____
DEPUTY CLERK

DATE

LIGHTING

RATE SCHEDULE: LT-1

AVAILABLE:

In all areas served.

APPLICATION:

For the purpose of lighting streets and roadways, area lighting including parking lots and common areas, whether public or privately owned, and outdoorlighting.

TYPE OF INSTALLATION:

All new installations will be light emitting diodes (LED). Company-owned fixtures normally will be mounted on poles of the Company's existing distribution system and served from overhead wires. For roadway and area lighting, excluding outdoor lighting, the Company may provide special poles or underground wires at the charges specified below. In addition, the Company, at its discretion, may offer the Customer the option of Company-owned fixtures attached to poles owned by the Customer. For these installations, the customer owned poles require pre-approval by a Company representative.

Outdoor lights can only be mounted on accessible existing distribution poles facing the customer's property.

The location and the type of the facilities are, and will continue to be, easily and economically accessible to the Company equipment and personnel for both construction and maintenance.

SERVICE:

Service includes energy from dusk each day until dawn the following day and maintenance of Company -owned lighting systems. Maintenance includes replacement or repair of any circuit component to assure the facilities are operational and safe. The Company will maintain its facilities during regular daytime working hours as soon as practicable following notification by the Customer that such work is necessary. The Company shall be permitted to enter the Customer's premises at all reasonable times for the purpose of inspecting, maintaining, installing and removing any or all of its equipment and facilities.

The Company, while exercising reasonable diligence at all times to furnish service hereunder, does not guarantee continuous lighting and will not be liable for damages for any interruption, deficiency or failure of service, and reserves the right to interrupt service at any time for necessary repairs to lines or equipment.

LIMITATION OF SERVICE:

Installation shall be made only when, in the judgement of the Company, the location and the type of the facilities are, and will continue to be, easily and economically accessible to the Company equipment and personnel for both construction and maintenance. Overhead conductors will not be installed in any area designated as an underground distribution area, or any area, premises or location served from an underground source.

For outdoor lights, customer must have an active house or premise account associated with this service.

Stand-by or resale service is not permitted hereunder.

CUSTOMER CONTRIBUTIONS:

A Contribution-in-Aid-of-Construction (CIAC) will be required for:

- a) the differential cost between employing rapid construction techniques in trenching, backfilling and pole installation work where no obstructions exist, and the added cost to overcome obstructions such as sprinkler systems, paved surfaces (such as sidewalks, curbs, gutters, and roadways), landscaping, sodding and other obstructions encountered along the Lighting System installation route, including repair and replacement. If the Customer elects to perform work such as trenching and restoration, they will be reimbursed by the Company with a credit (not to exceed the total CIAC cost) for the value of this work as determined by the Company;
- b) the installation cost of any new overhead distribution facilities and/or the cost of alterations to existing distribution facilities which are required in order to serve the Lighting System less four (4) times the additional annual non-fuel energy revenue generated by the installation or alteration of the Lighting System, plus where underground facilities are installed, the differential installation cost between underground and overhead distribution facilities.

These costs shall be paid by the Customer prior to the initiation of any construction work by the Company. The Customer shall also pay any additional costs associated with design modifications requested after the original estimate has been made.

REMOVAL OR RELOCATION OF FACILITIES:

If Company owned lighting facilities are removed by Customer request, breach of the Agreement or non-payment, the Customer may be responsible to pay the net book value for the fixtures, poles, and additional lighting facility charges plus the cost to remove the facilities. These charges do not apply to conversions of Company owned non-LED to Company owned LED lights.

When the Company relocates or removes its facilities to comply with governmental requirements, either the Company or the Customer shall have the right, upon written notice, to discontinue service hereunder without obligation or liability.

Facility relocations are treated as removals of facilities from the old location and installation of the new facilities in the new location. Facilities will not be transferred and reused at a new location.

In all cases, should the Customer request termination of the Agreement, such termination will require written notice 90 days prior to the date of termination.

CONVERSION OF COMPANY OWNED NON-LED LIGHTS TO COMPANY OWNED LED LIGHTS:

For customers converting, Company owned non-LED to Company owned LED Lights, the LED Conversion Recovery Charge will apply and there will be no charge for the fixtures being removed. Any other charges for relocation or replacement of Company owned facilities would still apply.

CHANGE IN FIXTURE SIZE OR TYPE:

At the Customer's request, the Company will change to a lower or higher level of illumination when the changes are consistent with good engineering practices. A LED fixture will be the only modification from an LED or non-LED fixture request. The Customer will pay the net book value of the existing fixture, plus removal costs and will receive a credit for 4 years additional revenue generated by the larger fixtures, if applicable. If changes are required to the distribution system to support the larger lights, standard CIAC charges as described on sheet 8.736 will also apply. The Customer will pay the Company the net costs incurred in making other fixture changes.

(Continued from Sheet No. 8.735.1)

MONTHLY RATES FOR MAINTENANCE AND CONVERSION:

| | |
|---|--------|
| Maintenance per Fixture (FPL Owned Fixture and Pole) | \$1.45 |
| Maintenance per Fixture for FPL fixtures on Customer Pole | \$1.16 |
| LED Conversion Recovery | \$2.08 |

MONTHLY RATES FOR POLES USED ONLY FOR LIGHTING SYSTEM:

| | |
|--------------------------|---------|
| Standard Wood pole | \$5.94 |
| Standard Concrete pole | \$8.14 |
| Standard Fiberglass pole | \$9.61 |
| Decorative Concrete pole | \$17.46 |

MONTHLY RATES FOR LEDFIXTURES*:

| Energy Tier | Charge | Fixture Tier | | | | | | | | | | | | | | |
|-------------|---------|--------------|-------|-------|-------|-------|-------|-------|-------|-------|-------|-------|-------|-------|-------|-------|
| | | 1 | 2 | 3 | 4 | 5 | 6 | 7 | 8 | 9 | 10 | 11 | 12 | 13 | 14 | 15 |
| A | \$ - | 1.50 | 4.50 | 7.50 | 10.50 | 13.50 | 16.50 | 19.50 | 22.50 | 25.50 | 28.50 | 31.50 | 34.50 | 37.50 | 40.50 | 43.50 |
| B | \$ 0.20 | 1.70 | 4.70 | 7.70 | 10.70 | 13.70 | 16.70 | 19.70 | 22.70 | 25.70 | 28.70 | 31.70 | 34.70 | 37.70 | 40.70 | 43.70 |
| C | \$ 0.40 | 1.90 | 4.90 | 7.90 | 10.90 | 13.90 | 16.90 | 19.90 | 22.90 | 25.90 | 28.90 | 31.90 | 34.90 | 37.90 | 40.90 | 43.90 |
| D | \$ 0.60 | 2.10 | 5.10 | 8.10 | 11.10 | 14.10 | 17.10 | 20.10 | 23.10 | 26.10 | 29.10 | 32.10 | 35.10 | 38.10 | 41.10 | 44.10 |
| E | \$ 0.80 | 2.30 | 5.30 | 8.30 | 11.30 | 14.30 | 17.30 | 20.30 | 23.30 | 26.30 | 29.30 | 32.30 | 35.30 | 38.30 | 41.30 | 44.30 |
| F | \$ 1.00 | 2.50 | 5.50 | 8.50 | 11.50 | 14.50 | 17.50 | 20.50 | 23.50 | 26.50 | 29.50 | 32.50 | 35.50 | 38.50 | 41.50 | 44.50 |
| G | \$ 1.20 | 2.70 | 5.70 | 8.70 | 11.70 | 14.70 | 17.70 | 20.70 | 23.70 | 26.70 | 29.70 | 32.70 | 35.70 | 38.70 | 41.70 | 44.70 |
| H | \$ 1.40 | 2.90 | 5.90 | 8.90 | 11.90 | 14.90 | 17.90 | 20.90 | 23.90 | 26.90 | 29.90 | 32.90 | 35.90 | 38.90 | 41.90 | 44.90 |
| I | \$ 1.60 | 3.10 | 6.10 | 9.10 | 12.10 | 15.10 | 18.10 | 21.10 | 24.10 | 27.10 | 30.10 | 33.10 | 36.10 | 39.10 | 42.10 | 45.10 |
| J | \$ 1.80 | 3.30 | 6.30 | 9.30 | 12.30 | 15.30 | 18.30 | 21.30 | 24.30 | 27.30 | 30.30 | 33.30 | 36.30 | 39.30 | 42.30 | 45.30 |
| K | \$ 2.00 | 3.50 | 6.50 | 9.50 | 12.50 | 15.50 | 18.50 | 21.50 | 24.50 | 27.50 | 30.50 | 33.50 | 36.50 | 39.50 | 42.50 | 45.50 |
| L | \$ 2.20 | 3.70 | 6.70 | 9.70 | 12.70 | 15.70 | 18.70 | 21.70 | 24.70 | 27.70 | 30.70 | 33.70 | 36.70 | 39.70 | 42.70 | 45.70 |
| M | \$ 2.40 | 3.90 | 6.90 | 9.90 | 12.90 | 15.90 | 18.90 | 21.90 | 24.90 | 27.90 | 30.90 | 33.90 | 36.90 | 39.90 | 42.90 | 45.90 |
| N | \$ 2.60 | 4.10 | 7.10 | 10.10 | 13.10 | 16.10 | 19.10 | 22.10 | 25.10 | 28.10 | 31.10 | 34.10 | 37.10 | 40.10 | 43.10 | 46.10 |
| O | \$ 2.80 | 4.30 | 7.30 | 10.30 | 13.30 | 16.30 | 19.30 | 22.30 | 25.30 | 28.30 | 31.30 | 34.30 | 37.30 | 40.30 | 43.30 | 46.30 |
| P | \$ 3.00 | 4.50 | 7.50 | 10.50 | 13.50 | 16.50 | 19.50 | 22.50 | 25.50 | 28.50 | 31.50 | 34.50 | 37.50 | 40.50 | 43.50 | 46.50 |
| Q | \$ 3.20 | 4.70 | 7.70 | 10.70 | 13.70 | 16.70 | 19.70 | 22.70 | 25.70 | 28.70 | 31.70 | 34.70 | 37.70 | 40.70 | 43.70 | 46.70 |
| R | \$ 3.40 | 4.90 | 7.90 | 10.90 | 13.90 | 16.90 | 19.90 | 22.90 | 25.90 | 28.90 | 31.90 | 34.90 | 37.90 | 40.90 | 43.90 | 46.90 |
| S | \$ 3.60 | 5.10 | 8.10 | 11.10 | 14.10 | 17.10 | 20.10 | 23.10 | 26.10 | 29.10 | 32.10 | 35.10 | 38.10 | 41.10 | 44.10 | 47.10 |
| T | \$ 3.80 | 5.30 | 8.30 | 11.30 | 14.30 | 17.30 | 20.30 | 23.30 | 26.30 | 29.30 | 32.30 | 35.30 | 38.30 | 41.30 | 44.30 | 47.30 |
| U | \$ 4.00 | 5.50 | 8.50 | 11.50 | 14.50 | 17.50 | 20.50 | 23.50 | 26.50 | 29.50 | 32.50 | 35.50 | 38.50 | 41.50 | 44.50 | 47.50 |
| V | \$ 4.20 | 5.70 | 8.70 | 11.70 | 14.70 | 17.70 | 20.70 | 23.70 | 26.70 | 29.70 | 32.70 | 35.70 | 38.70 | 41.70 | 44.70 | 47.70 |
| W | \$ 4.40 | 5.90 | 8.90 | 11.90 | 14.90 | 17.90 | 20.90 | 23.90 | 26.90 | 29.90 | 32.90 | 35.90 | 38.90 | 41.90 | 44.90 | 47.90 |
| X | \$ 4.60 | 6.10 | 9.10 | 12.10 | 15.10 | 18.10 | 21.10 | 24.10 | 27.10 | 30.10 | 33.10 | 36.10 | 39.10 | 42.10 | 45.10 | 48.10 |
| Y | \$ 4.80 | 6.30 | 9.30 | 12.30 | 15.30 | 18.30 | 21.30 | 24.30 | 27.30 | 30.30 | 33.30 | 36.30 | 39.30 | 42.30 | 45.30 | 48.30 |
| Z | \$ 5.00 | 6.50 | 9.50 | 12.50 | 15.50 | 18.50 | 21.50 | 24.50 | 27.50 | 30.50 | 33.50 | 36.50 | 39.50 | 42.50 | 45.50 | 48.50 |
| AA | \$ 5.20 | 6.70 | 9.70 | 12.70 | 15.70 | 18.70 | 21.70 | 24.70 | 27.70 | 30.70 | 33.70 | 36.70 | 39.70 | 42.70 | 45.70 | 48.70 |
| BB | \$ 5.40 | 6.90 | 9.90 | 12.90 | 15.90 | 18.90 | 21.90 | 24.90 | 27.90 | 30.90 | 33.90 | 36.90 | 39.90 | 42.90 | 45.90 | 48.90 |
| CC | \$ 5.60 | 7.10 | 10.10 | 13.10 | 16.10 | 19.10 | 22.10 | 25.10 | 28.10 | 31.10 | 34.10 | 37.10 | 40.10 | 43.10 | 46.10 | 49.10 |
| DD | \$ 5.80 | 7.30 | 10.30 | 13.30 | 16.30 | 19.30 | 22.30 | 25.30 | 28.30 | 31.30 | 34.30 | 37.30 | 40.30 | 43.30 | 46.30 | 49.30 |
| EE | \$ 6.00 | 7.50 | 10.50 | 13.50 | 16.50 | 19.50 | 22.50 | 25.50 | 28.50 | 31.50 | 34.50 | 37.50 | 40.50 | 43.50 | 46.50 | 49.50 |

* Catalog of available fixtures and the assigned billing tier for each can be viewed at www.FPL.com/partner/builders/lighting.html

The non-fuel energy charge is 3.410¢ per kWh; where the kWh is calculated as (wattage x 353.3 hours per month)/ 1000

SPECIAL PROVISIONS:

Where the Company provides fixtures or poles other than those referenced above, the monthly charges, as applicable shall be computed as follows:

Charge: 1.28% of the Company's average installed cost of the pole, light fixture, or both.

Standard maintenance fees to apply
Standard non-fuel Energy Charge to apply

ADDITIONAL LIGHTING CHARGE:

Any special or additional lighting charges, which are required by the Company, will be billed in addition to the above rates.

Charge: 1.28% of the Company's average installed cost of the additional lighting facilities.

As of January 1, 2022, the factor pertaining to Underground Conductor will be closed to new customers.
Underground Conductor 4.865¢ per foot

BILLING

During the initial installation period:

- Facilities in service for 15 days or less will not be billed;
- Facilities in service for 16 days or more will be billed for a full month.

For outdoor lights only, the Company has the right at any time to remove the light for non-payment and decline new request to customers with prior non-payment activity.

WILLFUL DAMAGE:

Upon the second occurrence of willful damage to any Company-owned facilities, the Customer will be responsible for the cost incurred for repair or replacement. If the lighting fixture is damaged, based on prior written instructions from the Customer, the Company will:

- a) If a commercially available and Company approved device exists, install a protective shield. The Customer shall pay \$280.00 for the shield plus all associated costs. However, if the Customer chooses to have the shield installed before the second occurrence, the Customer shall only pay the cost of the shield; or
- b) Replace with a like unshielded fixture. For this, and each subsequent occurrence, the Customer shall pay the estimated costs of the replacement fixture; or
- c) Terminate service to the fixture. In this case, the lighting facilities will be removed from the field and from billing; the Customer will pay the lighting facilities charges for the remaining period of the currently active term of service plus the cost to remove the facilities.

Option selection shall be made by the Customer in writing and apply to all fixtures which the Company has installed on the Customer's behalf on the same account. Selection changes may be made by the Customer at any time and will become effective ninety (90) days after written notice is received.

(Continued on Sheet No. 8.738)

(Continued from Sheet No. 8.737)

OTHER CHARGES

See Billing Adjustments section, Sheet No. 8.030, for additional applicable charges.

SPECIAL CONDITIONS:

Customers whose lights are turned off during sea turtle nesting season will receive a credit equal to the non-fuel charges associated with the fixtures that are turned off.

TERM OF SERVICE:

Service for outdoor lighting will be established for a minimum of one (1) year unless terminated by either the Company or the Customer.

All other services, besides outdoor lighting mentioned above, will require a Lighting Agreement.

Lighting agreements will have an initial term of ten (10) years with automatic, successive five (5) year extensions unless renegotiated or terminated in writing by either the Company or the Customer at least ninety (90) days prior to the current term's expiration. In the event of the sale of the real estate property upon which the facilities are installed, upon the written consent of the Company, the contract may be assigned by the Customer to the Purchaser. No assignment shall not relieve the Customer from its obligations hereunder until such obligations have been assumed by the assignee and agreed to by the Company.

Term of service begins upon execution of the Lighting Agreement.

All governmental or commercial / industrial customer contracts to be executed by property owner or governing body.

All existing contract terms prior to January 1, 2022 will be honored.

RULES AND REGULATIONS:

Service under this schedule is subject to orders of governmental bodies having jurisdiction and to the currently effective "General Rules and Regulations for Electric Service" on file with the Florida Public Service Commission. In case of conflict between any provision of this schedule and said, "General Rules and Regulations for Electric Service", the provision of this schedule shall apply.

Memorandum



Date: September 16, 2020

To: Maria Nardi, Director
Department of Parks, Recreation and Open Spaces

From: Jack Osterholt, Deputy Mayor/Director
Department of Regulatory and Economic Resources

Subject: Street lighting, Maintenance of Landscape, Walls Adjacent to Double Frontage Lots, Entrance Features and Lakes – Special Taxing Districts

All tentative plats in the unincorporated area of Miami-Dade County submitted to the Development Services Division (Land Development Section) of the Regulatory and Economic Resources Department (RER), must comply with the special taxing districts requirements of the Miami-Dade County Code (the Code) including, but not limited to street lights, maintenance of landscape, walls adjacent to double frontage lots, entrance features and lakes. Final Plats will not be presented to the Board of County Commissioners for consideration until the applicable special taxing districts are created, and all fees have been paid. In that regard, to ensure expeditious processing, this Memorandum may serve, through September 30, 2021, as approval for certain future special taxing district application requests as being consistent with the intent and purpose of the adopted 2020-2030 Comprehensive Development Master Plan (CDMP). Capital Improvement Element Policy CIE-4A states: “Appropriate funding mechanisms will be adopted and applied by Miami-Dade County and the Miami-Dade County Public Schools in order to assure the fiscal resources to maintain acceptable levels of service. Such funding mechanisms may include special taxing districts, municipal taxing service units, local option taxes, user fees, local gas tax, general obligation bonds, impact fees, special purpose authorities, and others as appropriate and feasible” (Adopted Components as Amended through January 23, 2020, page IX-9). The provision for services over and above minimum for neighborhoods and communities may be accomplished through the special taxing district as may be prescribed by the Code.

The RER has no objection to a blanket approval with condition to establish future special taxing districts as limited to requests for street lighting, landscape maintenance, walls adjacent to double frontage lots and lake maintenance districts. The previously noted special taxing districts may be established on the condition that the RER Development Services Division review all landscape maintenance districts and lake maintenance districts for consistency with Landscape Code (Chapter 18A) Section 18A-6(L) Storm Water Retention/Detention Areas.

JO:LG:NK:JB:GR

EXIST.
DORAL INTERNATIONAL PARK
S.T.D. (L-585)

DISTRICT BOUNDARIES

NW 41 STREET
(LIT BY ARTERIAL LIGHTS)

EXIST.
MIAMI INTERNATIONAL BUSINESS PARK
S.T.D. (L-556)



THEO. NW 113 AVENUE

TRACT "A"

NW 112 AVENUE

EXIST. BRIDGE DORAL S.T.D. (L-1521)

NW 34 STREET

TRACT "B"

THEO. NW 33 TERRACE

BRIDGE DORAL WEST STREET LIGHTING SPECIAL TAXING DISTRICT

11 - ROADWAY (31,500 LUMENS, 4000K) COBRA HEAD LED STREETLIGHTS
MOUNTED ON CONCRETE POLES.

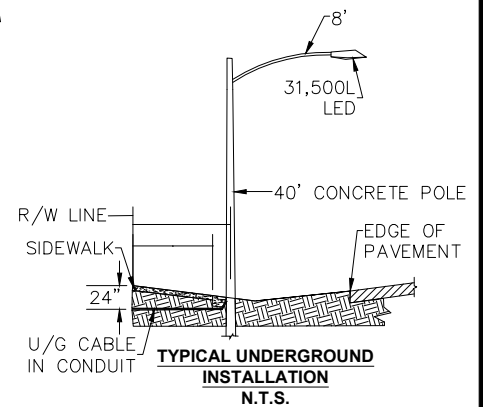

L-1522 (COMM. 0012)
SECTION: 30 - 53 - 40

EXHIBIT "A"
(BOUNDARIES & GEOGRAPHICAL LOCATION SKETCH)

3/21/2024

MDC027



MEMORANDUM
(Revised)

TO: Honorable Chairman Oliver G. Gilbert, III
and Members, Board of County Commissioners

DATE: June 4, 2024

FROM: 
Gen Bonzon-Keenan
County Attorney

SUBJECT: Agenda Item No. 5(F)

Please note any items checked.

- "3-Day Rule" for committees applicable if raised
- 6 weeks required between first reading and public hearing
- 4 weeks notification to municipal officials required prior to public hearing
- Decreases revenues or increases expenditures without balancing budget
- Budget required
- Statement of fiscal impact required
- Statement of social equity required
- Ordinance creating a new board requires detailed County Mayor's report for public hearing
- No committee review
- Applicable legislation requires more than a majority vote (i.e., 2/3's present ____, 2/3 membership ____, 3/5's ____, unanimous ____, CDMP 7 vote requirement per 2-116.1(3)(h) or (4)(c) ____, CDMP 2/3 vote requirement per 2-116.1(3)(h) or (4)(c) ____, or CDMP 9 vote requirement per 2-116.1(4)(c)(2) ____) to approve
- Current information regarding funding source, index code and available balance, and available capacity (if debt is contemplated) required

Approved _____ Mayor
Veto _____
Override _____

Agenda Item No. 5(F)
6-4-24

ORDINANCE NO. _____

ORDINANCE CREATING AND ESTABLISHING A SPECIAL TAXING DISTRICT IN MIAMI-DADE COUNTY, FLORIDA, GENERALLY BOUNDED ON THE NORTH BY NW 41 STREET, ON THE EAST BY NW 112 AVENUE, ON THE SOUTH BY THEORETICAL NW 33 TERRACE, AND ON THE WEST BY THEORETICAL NW 113 AVENUE, KNOWN AND DESCRIBED AS BRIDGE DORAL WEST STREET LIGHTING SPECIAL TAXING DISTRICT; IDENTIFYING SERVICES TO BE PROVIDED; AND PROVIDING FOR EXCLUSION FROM THE CODE AND AN EFFECTIVE DATE

WHEREAS, this Board desires to accomplish the purposes outlined in the accompanying memorandum, which is incorporated herein by reference; and

WHEREAS, a public hearing has been conducted by the Board of County Commissioners in accordance with the requirements and procedures of chapter 18 of the Code of Miami-Dade County,

BE IT ORDAINED BY THE BOARD OF COUNTY COMMISSIONERS OF MIAMI-DADE COUNTY, FLORIDA:

Section 1. This Board incorporates and approves the foregoing recitals as if fully set forth herein.

Section 2. In accordance with the provisions of chapter 18 of the Code, a special taxing district, to be known and designated as the Bridge Doral West Street Lighting Special Taxing District is hereby created and established in the City of Doral (“City”), Florida, pursuant to City Resolution No. 23-182.

Section 3. The area or boundaries of this Special Taxing District, generally bounded on the north by NW 41 Street, on the east by NW 112 Avenue, on the south by theoretical NW 33 Terrace, and on the west by theoretical NW 113 Avenue, and located entirely within District 12, are as follows:

Parcels of land lying in Section 30, Township 53 South, Range 40 East, Miami-Dade County, Florida (a.k.a. Bridge Doral West, Tentative Plat #T-24917); being more particularly described as follows:

Those portions of the E3/5 of Section 30, Township 53 South, Range 40 East, Miami-Dade County, Florida, less the north 55.00 and the south 2,795.85 feet thereof, being more particularly described as follows:

Parcel 1

Beginning at the intersection of the west line of the NE1/4 of said Section 30 with a line lying 55.00 feet south and parallel to the north line of said NE1/4 of Section 30; thence N89°34'32"E along said parallel line thence 38.70 feet; thence S00°25'28"E 2039.53 feet; thence S01°34'32"W 301.57 feet; thence S88°15'10"W 5.00 feet; thence S01°42'44"E 50.54 feet to a point on the arc of a circular curve concave southwesterly from which a radial line bears S88°15'10"W; thence northwesterly along the arc of said curve to the left also being the north Right-of-Way line of NW 34th Street, having a radius of 105.00 feet and a central angle of 88°40'29", for an arc distance of 162.50 feet to a point of tangency; thence S89°34'41"W along said north Right-of-Way line 390.06 feet to a point on the west line of said E3/5 of Section 30; thence N01°44'50"W along said west line 2289.61 feet to a point on a line lying 55.00 feet south and parallel to the north line of the NW1/4 of said Section 30; thence N89°34'42"E along said parallel line 523.57 feet to the Point of Beginning.

And

Parcel 2

Beginning at the southwest corner of said E3/5 of Section 30, Township 53 South, Range 40 East, less the south 2,795.85 feet thereof; thence N01°44'50"W along the west line of said E3/5 of Section 30 for 68.99 feet to a point on the south Right-of-Way line of NW 34th Street; thence along said south Right-of-Way line the

following three (3) courses and distances: (1) N89°34'41"E 363.78 feet to a point of curvature of a circular curve to the right; thence southeasterly along the arc of said curve, having a radius of 50.00 feet and a central angle of 88°40'29", for an arc distance of 77.38 feet to a point of tangency; thence S01°44'50"E 20.45 feet to a point on the north line of said south 2,795.85 feet of Section 30; thence S89°37'22"W along said line 412.65 feet to the Point of Beginning.

The areas and geographical locations of this Special Taxing District are shown on the map or sketch, attached to the accompanying memorandum.

Section 4. The improvements and/or services to be provided in this Special Taxing District will consist of street lighting services within public rights-of-way, as described in the Report.

Section 5. The installation of such street lighting will be accomplished pursuant to an agreement between the City and Florida Power and Light. The expected costs of the installation and operation of the Special Taxing District's services, including maintenance, electricity, engineering, administration, billing, collection and processing, for the first year are provided by petitioners and estimated to be \$35,736.26. The succeeding years' assessments will be adjusted based on actual costs.

Section 6. The entire cost of the Special Taxing District's improvements and/or services shall be specially assessed. It is hereby declared that said services will be a special benefit to all properties within the Special Taxing District and the total amount of special assessments to be levied as aforesaid will not be in excess of such benefit.

Section 7. The County Mayor or County Mayor's designee, or the City if transferred, is authorized and directed to cause the installation of said streetlights to be accomplished within the Special Taxing District in accordance with the provisions of said agreement and the terms of this Ordinance.

Section 8. In accordance with the provisions of sections 18-14 and 18-22.1 of the Code and as authorized by section 197.3632, Florida Statutes, all special assessments levied and imposed under the provisions of this Ordinance shall be collected, subject to the provisions of chapter 197, Florida Statutes, in the same manner and at the same time as ad valorem taxes. Unless paid when due, such assessments shall be deemed delinquent and payment thereof may be enforced by means of the procedures provided by the provisions of chapter 197, Florida Statutes, and section 18-14 of the Code, including possible loss of title.

Section 9. A duly certified copy of this Ordinance shall be filed in the Office of the Clerk of the Circuit Court of Miami-Dade County, Florida, and recorded in the appropriate book of records.

Section 10. It is the intention of this Board and it is hereby ordained that the provisions of this Ordinance shall be excluded from the Code.

Section 11. The provisions of this Ordinance shall become effective 10 days after the date of enactment, unless vetoed by the Mayor, and if vetoed, shall become effective only upon an override by this Board.

PASSED AND ADOPTED:

Approved by County Attorney as
to form and legal sufficiency:

EWJ for

Prepared by:

RC

Ryan Carlin